

6012A
AUTORANGING
DC POWER SUPPLY

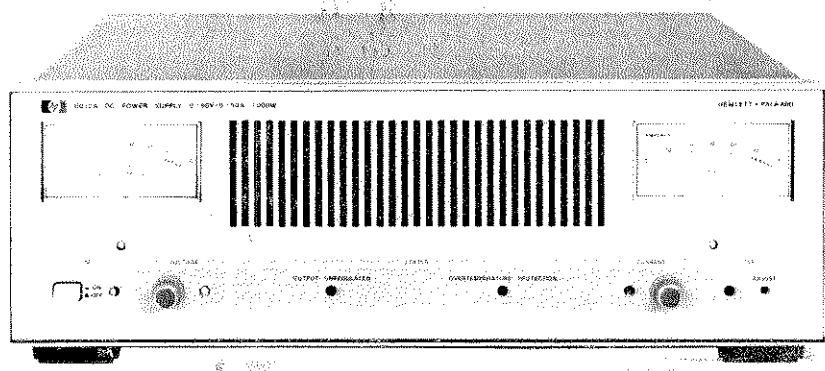

hp HEWLETT
PACKARD

HP 6012A



**HEWLETT
PACKARD**

CERTIFICATION

Hewlett-Packard Company certifies that this product met its published specifications at the time of shipment from the factory. Hewlett-Packard further certifies that its calibration measurements are traceable to the United States National Bureau of Standards, to the extent allowed by the Bureau's calibration facility, and to the calibration facilities of other International Standards Organization members.

WARRANTY

This Hewlett-Packard instrument product is warranted against defects in material and workmanship for a period of one year from date of shipment. During the warranty period, Hewlett-Packard Company will, at its option, either repair or replace products which prove to be defective.

For warranty service or repair, this product must be returned to a service facility designated by HP. Buyer shall prepay shipping charges to HP and HP shall pay shipping charges to return the product to Buyer. However, Buyer shall pay all shipping charges, duties, and taxes for products returned to HP from another country.

HP warrants that its software and firmware designated by HP for use with an instrument will execute its programming instructions when properly installed on that instrument. HP does not warrant that the operation of the instrument, or software, or firmware will be uninterrupted or error free.

LIMITATION OF WARRANTY

The foregoing warranty shall not apply to defects resulting from improper or inadequate maintenance by Buyer, Buyer-supplied software or interfacing, unauthorized modification or misuse, operation outside of the environmental specifications for the product, or improper site preparation or maintenance.

NO OTHER WARRANTY IS EXPRESSED OR IMPLIED. HP SPECIFICALLY DISCLAIMS THE IMPLIED WARRANTIES OF MERCHANTABILITY AND FITNESS FOR A PARTICULAR PURPOSE.

EXCLUSIVE REMEDIES

THE REMEDIES PROVIDED HEREIN ARE BUYER'S SOLE AND EXCLUSIVE REMEDIES. HP SHALL NOT BE LIABLE FOR ANY DIRECT, INDIRECT, SPECIAL, INCIDENTAL, OR CONSEQUENTIAL DAMAGES, WHETHER BASED ON CONTRACT, TORT, OR ANY OTHER LEGAL THEORY.

ASSISTANCE

Product maintenance agreements and other customer assistance agreements are available for Hewlett-Packard products.

For any assistance, contact your nearest Hewlett-Packard Sales and Service Office. Addresses are provided at the back of this manual.



**HEWLETT
PACKARD**

**AUTORANGING
DC POWER SUPPLY
MODEL 6012A**

**OPERATING AND SERVICE MANUAL FOR
SERIALS 1946A-00101 AND ABOVE***

***For Serials above 1946A-00101
a change page may be included.**

SAFETY SUMMARY

The following general safety precautions must be observed during all phases of operation, service, and repair of this instrument. Failure to comply with these precautions or with specific warnings elsewhere in this manual violates safety standards of design, manufacture, and intended use of the instrument. Hewlett-Packard Company assumes no liability for the customer's failure to comply with these requirements.

GROUND THE INSTRUMENT.

To minimize shock hazard, the instrument chassis and cabinet must be connected to an electrical ground. The instrument must be connected to ac power through a three-conductor power cable, with the third wire firmly connected to an electrical ground (safety ground) at the power outlet.

DO NOT OPERATE IN AN EXLOSIVE ATMOSPHERE.

Do not operate the instrument in the presence of flammable gases or fumes. Operation of any electrical instrument in such an environment constitutes a definite safety hazard.

KEEP AWAY FROM LIVE CIRCUITS.

Operating personnel must not remove instrument covers. Component replacement and internal adjustments must be made by qualified maintenance personnel. Do not replace components with power cable connected. Under certain conditions, dangerous voltages may exist even with the power cable removed. To avoid injuries, always disconnect power, discharge circuits and remove floating voltages before touching components.

DO NOT SERVICE OR ADJUST ALONE.

Do not attempt internal service or adjustment unless another person, capable of rendering first aid and resuscitation, is present.

SAFETY SYMBOLS.



Caution symbol. Advises the operator to refer to the instruction manual for additional information.



Indicates terminal intended to be connected to system ground.

DO NOT SUBSTITUTE PARTS OR MODIFY INSTRUMENT.

Because of the danger of introducing additional hazards, do not install substitute parts or perform any unauthorized modification to the instrument. Return the instrument to a Hewlett-Packard Sales and Service Office for service and repair to ensure that safety features are maintained.

DO NOT EXCEED INPUT RATINGS.

"This instrument is equipped with a line filter to reduce electromagnetic interference and must be connected to a properly grounded receptacle to minimize electric shock hazard. Operation at line voltages or frequencies in excess of those stated on the data plate may cause leakage currents in excess of 3.5 mA."

TABLE OF CONTENTS

Section	Page	Section	Page
I GENERAL INFORMATION		3-37 Remote Voltage Sensing	3-5
1-1 DESCRIPTION	1-1	3-42 Remote Programming	3-6
1-8 SAFETY CONSIDERATIONS	1-1	3-61 Auto-Parallel Operation	3-9
1-10 SPECIFICATIONS	1-1	3-67 Auto-Series Operation	3-10
1-12 INSTRUMENT AND MANUAL IDENTIFICATION	1-1	3-82 Auto-Tracking Operation	3-12
1-15 OPTIONS	1-1	3-96 I-MONITOR OUTPUT SIGNAL	3-14
1-17 ACCESSORIES	1-2		
1-19 ORDERING ADDITIONAL MANUALS	1-2	IV PRINCIPLES OF OPERATION	
II INSTALLATION		4-1 DIFFERENCE BETWEEN AN AUTORANGING POWER SUPPLY AND A CONVENTIONAL POWER SUPPLY	4-1
2-1 INITIAL INSPECTION	2-1	4-3 SIMPLIFIED SCHEMATIC DESCRIPTION	4-1
2-3 Mechanical Check	2-1	4-5 Basic Concept	4-1
2-5 REPACKAGING FOR SHIPMENT	2-1	4-8 Input AC Circuits	4-1
2-9 PREPARATION	2-1	4-17 Constant Voltage (CV) Circuit	4-3
2-11 Location and Cooling	2-1	4-21 Constant Current (CC) Circuit	4-3
2-13 Outline Diagram	2-2	4-24 Control Voltage	4-4
2-15 Input Power Requirements	2-2	4-27 Pulse Width Modulator (PWM)	4-4
2-17 Power Connection	2-2	4-30 PWM Fast Turn Off	4-4
2-20 Rack Mounting	2-3	4-32 Primary Current (I_p) Limit	4-5
2-22 AC LINE IMPEDANCE CHECK	2-3	4-36 Down Programmer	4-5
2-25 LINE VOLTAGE OPTION CONVERSION	2-3	4-39 Overvoltage Protection Circuit (OVP)	4-5
III OPERATING INSTRUCTIONS		4-42 AC Dropout Detector/Slow-Start Circuit	4-5
3-1 INTRODUCTION	3-1	4-45 Bias Voltage Detector	4-5
3-4 TURN-ON CHECKOUT PROCEDURE	3-1	V MAINTENANCE	
3-6 CONNECTING THE LOAD	3-1	5-1 INTRODUCTION	5-1
3-14 PROTECTIVE CIRCUITS	3-3	5-3 TEST EQUIPMENT REQUIRED	5-1
3-16 OPERATING MODES	3-3	5-5 PERFORMANCE TEST	5-2
3-19 NORMAL OPERATING MODE	3-3	5-7 Measurement Techniques	5-2
3-27 Constant Voltage Operation	3-4	5-12 Constant Voltage Tests	5-2
3-31 Overvoltage Protection (OVP)	3-4	5-42 Constant Current Tests	5-6
3-35 ALTERNATE OPERATING MODES	3-5		

Section	Page	Section	Page
5-52	TROUBLESHOOTING	5-7	
5-57	Initial Troubleshooting Pro- cedures	5-7	
5-60	Overall Trouble Isolation	5-10	
5-63	REPAIR AND REPLACE- MENT	5-13	
5-64	Outside Cover Removal	5-13	
5-67	A2 Control Board Removal	5-14	
5-69	A3 FET Boards And A4 Output Diode Board Removal	5-14	
5-71	FET Board Disassembly	5-14	
5-73	Output Diode Board Disassembly	5-15	
5-75	A1 Main Board Removal	5-15	
5-77	Relay K1 Removal	5-16	
5-79	Component Access Through Bottom Chassis	5-16	
5-81	Front Panel Removal	5-16	
5-83	Replacement Parts	5-17	
5-86	ADJUSTMENT AND CALI- BRATION	5-17	
5-90	Meter Zero Adjustment	5-17	
		5-92	Ip Limit Adjustment
		5-94	Constant Voltage Offset Adjust- ment
		5-96	Constant Current Full Scale and Offset Adjustment
		5-98	Constant-Current-Source Adjustment
		5-100	Ammeter Adjustment
		5-102	Voltmeter Adjustment
		VI	REPLACEABLE PARTS
		6-1	INTRODUCTION
		6-4	ORDERING INFORMATION
		VII	COMPONENT LOCATION ILLUSTRATIONS AND CIRCUIT DIAGRAMS
			7-1
		APPENDIX A	
		SYSTEM OPTION 002	A-1
		APPENDIX B	
		100 Vac INPUT POWER OPTION 100	B-1

SECTION I

GENERAL INFORMATION

1-1 DESCRIPTION

1-2 The Model 6012A Autoranging Power Supply provides laboratory-grade performance with the high efficiency of switching regulation techniques. Autoranging allows the supply to provide at least 1000 watts output power over a wide range of output voltage and current combinations without the user having to select the proper output range. The output is adjustable through the entire operating range of 0 to 60 volts and 0 to 50 amperes by 10-turn front-panel controls.

1-3 The supply is of the Constant Voltage/Constant Current (CV/CC) type, with green front-panel LEDs to indicate whether the unit is operating in CV or CC mode. Output voltage and current are continuously indicated on individual front-panel meters. A secondary scale on the voltmeter indicates Amperes Available within the maximum output-power range; a secondary scale on the ammeter indicates Volts Available.

1-4 Overvoltage protection (OVP) protects the user's load by quickly and automatically interrupting energy transfer if a preset trip voltage is exceeded. A screwdriver control on the front panel sets the OVP trip point between 2V and 63V. A red LED on the front panel indicates that OVP has tripped.

1-5 Output connections are made to bus bars on the rear panel. Either the positive or negative output terminal may be grounded, or the output may be floated up to $\pm 240\text{Vdc}$ (including output voltage) from ground.

1-6 Remote programming, remote or local voltage sensing, and several methods of operating multiple-supply combinations for increased output voltage or current capability are possible by making connections to rear-panel terminals. These capabilities are more fully described in Section III.

1-7 The 6012A is considerably smaller, lighter, and dissipates less power than older-design supplies with similar output-power capability. The unit is fan cooled and is packaged in a Hewlett-Packard System II-compatible modular enclosure, which is sturdy, attractive, and provides easy access for servicing.

1-8 SAFETY CONSIDERATIONS

1-9 This product is a Safety Class 1 instrument (provided with a protective earth terminal). The instrument and this manual should be reviewed for safety markings and instructions before operation.

1-10 SPECIFICATIONS

1-11 Detailed specifications for the power supply are given in Table 1-1.

1-12 INSTRUMENT AND MANUAL IDENTIFICATION

1-13 Hewlett-Packard power supplies are identified by a two-part serial number. The first part is the serial number prefix, a number-letter combination that denotes the date of a significant design change and the country of manufacture. The first two digits of the prefix indicate the year (20 = 80, 21 = 81, etc.), the second two digits indicate the week, and the letter "A" designates the USA as the country of manufacture. The second part of the serial number is a different sequential number assigned to each power supply, starting with 00101.

1-14 If the serial number on your instrument does not agree with those on the title page of this manual, a yellow Manual Changes sheet supplied with the manual defines the difference between your instrument and the instrument described by this manual.

1-15 OPTIONS

1-16 Options are standard factory modifications that are requested by the customer. The following options are available with this instrument. Option 002 is described in Appendix A, Option 100 is described in Appendix B.

<u>Option No.</u>	<u>Description</u>
002	Systems Option: allows the supply to operate automatically in system applications. Provides resistance, voltage, and current programming of output voltage and current; six isolated status lines; three isolated control lines; +5V and $\pm 15\text{V}$ bias voltages. This option is mounted on a single additional printed-circuit board, which includes a rear-panel connector.
100	Input Power: 87 to 106 Vac, 48 to 63 Hz, single phase. Output: 675 W, 50 V, 50 A.
220	Input Power: 191 to 233 Vac, 48 to 63 Hz, single phase.
240	Input Power: 208 to 250 Vac, 48 to 63 Hz, single phase.
910	One additional operating and service manual shipped with the power supply for each Option 910 ordered.

1-17 ACCESSORIES

1-18 The System II Cabinet accessories listed below may be ordered with the power supply or separately from your local Hewlett-Packard Sales and Service Office (see list of addresses at the rear of this manual).

<u>HP Part No.</u>	<u>Description</u>
5061-0089	Front handle kit for 5-1/4 inch high cabinets.
1460-1345	Tilt stand (1) snaps into standard foot supplied with instrument, must be used in pairs.
5061-0077	Rack flange kit for 5-1/4 inch high cabinets (will be shipped with instrument if ordered as Option 908).
5061-0083	Rack flange/front handle kit for 5-1/4 inch high cabinets (will be shipped with instrument if ordered as Option 909).

HP Part No.

Description

1494-0018	Slide kit for installing 17-inch deep cabinet in HP rack enclosure.
1494-0025	Tilt slide kit, same as 1494-0018 plus permits tilting instrument up or down 90°.
1494-0023	Slide adapter kit, permits use of 1494-0018 kit in non-HP rack enclosure of adequate depth.
5060-2809	Control Board Extender card.

1-19 ORDERING ADDITIONAL MANUALS

1-20 One manual is shipped with each power supply. Additional manuals may be purchased directly from your local Hewlett-Packard Sales office. Specify the model number, instrument serial number prefix, and the manual part number provided on the title page. (When ordered at the same time as the power supply, additional manuals may be purchased by adding Option 910 to the order and specifying the number of additional manuals desired.)

Table 1-1. Specifications, Model 6012A

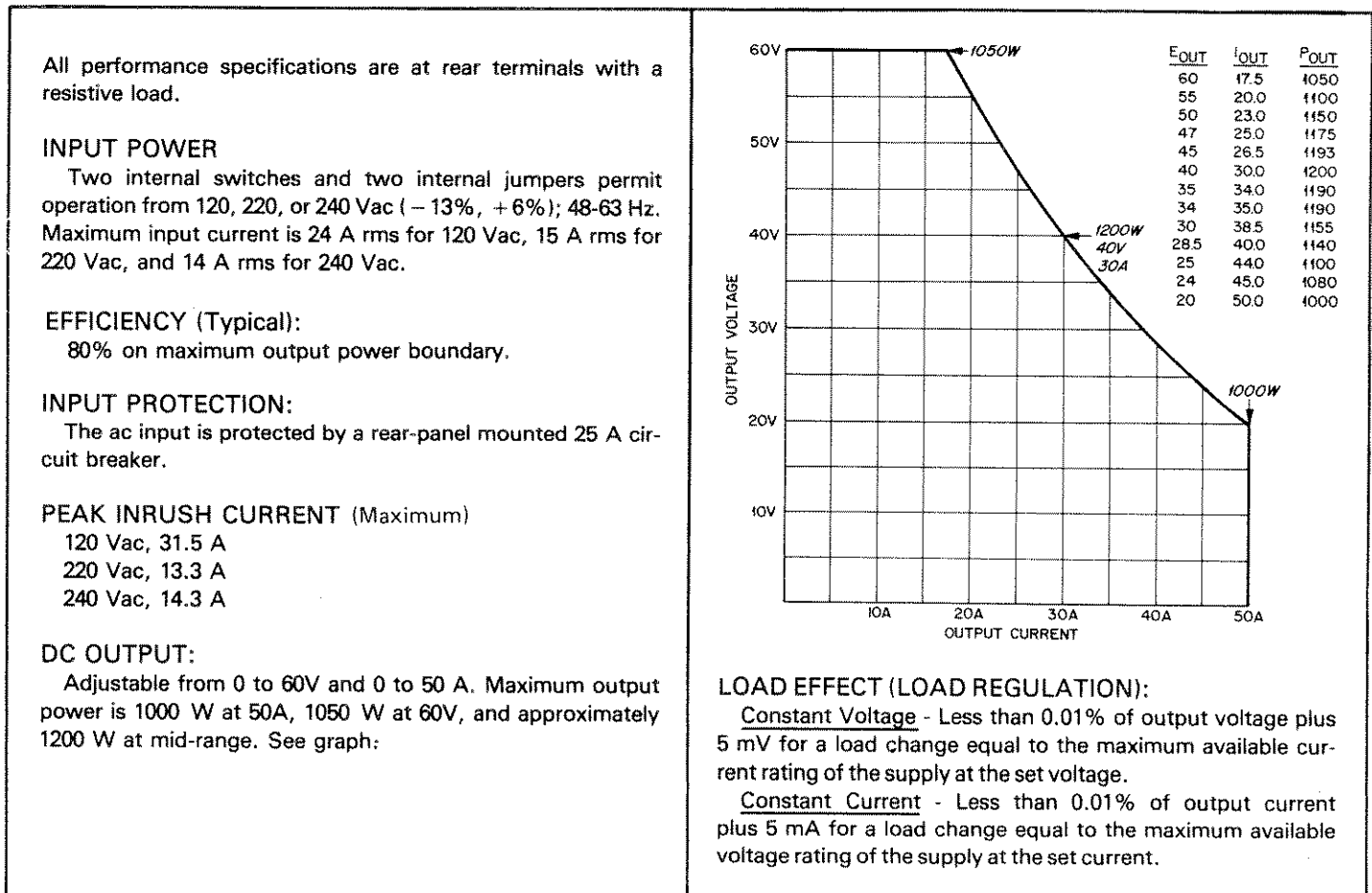

Table 1-1. Specifications, Model 6012A (continued)

SOURCE EFFECT (LINE REGULATION):

Constant Voltage - Less than 0.01% of output voltage plus 3 mV for any line voltage change within rating.

Constant Current - Less than 0.01% of output current plus 5 mA for any line voltage change within rating.

PARD (Ripple and Noise), 20 Hz to 20 MHz:

Constant Voltage - Less than 5 mV rms and 50 mV p-p.

Constant Current - Less than 25 mA rms.

TEMPERATURE COEFFICIENT:

Constant Voltage - Less than 0.01% plus 2 mV change in output per degree Celsius change in ambient after 30-minute warmup.

Constant Current - Less than 0.01% plus 4 mA change in output per degree Celsius change in ambient after 30-minute warmup.

DRIFT (Stability):

(Change in output over an 8-hour interval under constant line, load, and ambient temperature after 30-minute warmup).

Constant Voltage - Less than 0.03% of output plus 5 mV.

Constant Current - Less than 0.03% of output plus 5 mA.

LOAD TRANSIENT RECOVERY TIME:

Less than 2 ms is required for output voltage recovery (in constant voltage operation) to within 100 mV of the nominal output following a change in output current of 10% of maximum current rating at any output voltage (output current $\geq 5A$).

RESOLUTION:

(Minimum output voltage or current change that can be obtained using the 10-turn front-panel controls).

Constant Voltage - 20 mV

Constant Current - 20 mA

OUTPUT IMPEDANCE (Typical):

0.2 m Ω @ dc. See graph:

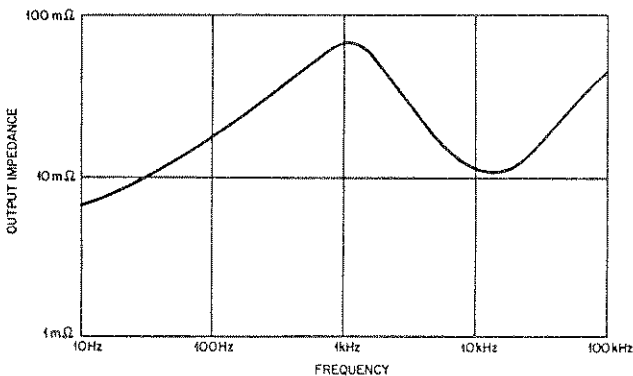

DC OUTPUT ISOLATION:

Either output terminal may be floated up to ± 240 Vdc (including output voltage) from ground.

OVERVOLTAGE PROTECTION:

Trip voltage adjustable from 2 V to 63 V. Minimum setting above output voltage to avoid false tripping is 1.5 V + 1% of V_{OUT} .

REVERSE VOLTAGE PROTECTION:

(Maximum permissible current caused by reverse voltage impressed across output terminals) 50 A continuous, 20 A continuous with ac power off.

REMOTE SENSING:

Maintains nominal voltage at load by correcting for load-lead voltage drop of up to 0.5V per lead.

REMOTE PROGRAMMING:

Resistance Programming - 0 to 2.5 k provides zero to maximum rated voltage or current output.

Accuracy: CV; 1% + 3 mV CC; 2.5% + 15 mA

Voltage Programming - 0 to 5V provides zero to maximum rated voltage or current output.

Accuracy: CV; 0.3% + 3 mV CC; 1% + 15 mA

Current Programming - 2 mA to 0 mA current sink provides zero to maximum rated voltage or current output (with user-provided 2.5k resistor).

Accuracy: CV; 0.3% + 0.42V + accuracy of resistor

CC; 1% + 0.8A + accuracy of resistor

PROGRAMMING RESPONSE TIME:

Maximum time for output voltage to change from 0 V to 60 V or 60 V to 2 V and settle within 200 mV band.

Up: Full load (3.4 Ω)	120 ms
No Load	120 ms
Down: Full Load (3.4 Ω)	400 ms
No Load	1.2 s

Typical response time to settle within 200 mV band, for excursions other than full-scale.

Down: On graph, read difference in time between initial output voltage and final output voltage; add settling time of 200 ms @ full load or 330 ms @ no load.

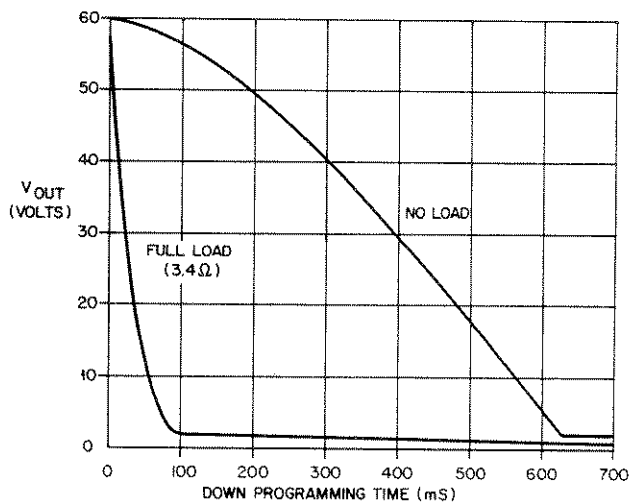
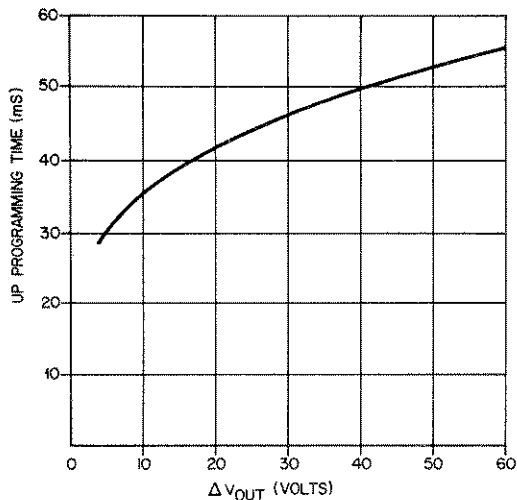

Table 1-1. Specifications, Model 6012A (continued)

Up: On graph, read time for change in output voltage.



CURRENT MONITORING OUTPUT:

0 to 5 V output from rear-panel terminal indicates zero to maximum rated current output; accuracy, 1% + 10 mV; output impedance, 10k.

METERS AND INDICATORS:

Voltmeter - Continuously reading 70 V scale with secondary scale indicating amperes available; accuracy, $\pm 3\%$ of full scale.

Ammeter - Continuously reading 60 A scale with secondary scale indicating volts available; accuracy, $\pm 3\%$ of full scale.

VOLTAGE Indicator - Green LED indicates Constant Voltage operation.

CURRENT Indicator - Green LED indicates Constant Current operation.

OUTPUT UNREGULATED Indicator - Red LED indicates that output is unregulated because of any of the following conditions: overrange operation, overvoltage, over temperature, or low-input-power shutdown.

OVP Indicator - Red LED indicates shutdown caused by voltage at output terminals exceeding preset limit.

OVERTEMPERATURE Indicator - Red LED indicates shutdown because of FET or output diode overtemperature.

MULTIPLE UNIT OPERATION:

Auto Parallel - Any number of units may be connected in parallel to increase total output current capability while maintaining control from a single unit.

Auto-Series - Up to four units (eight if center-tapped to ground) may be connected in series to increase total output voltage to 240 Vdc (480 Vdc if center-tapped to ground) while maintaining control from a single unit.

Auto-Tracking - Any number of units may have either one of their output terminals connected to a common bus so that all outputs track, at some fraction, the output of a single, controlled, unit.

TEMPERATURE RATINGS:

Operating: 0 to +50°C Storage: -40 to +75°C
 Unit is fan cooled. Thermostats turn off unit if FET or output diode temperatures rise above a critical level; reset automatically.

BACKPRESSURE:

Unit will operate against static backpressure at air outlet (rear panel) of up to 0.06 inches of water (air inlet at 0 inches of water).

CERTIFICATION:

- Unit complies with these requirements:
- IEC 348 - Safety Requirements for Electronic Measuring Apparatus.
- CSA Electrical Bulletin 556B - Electronic Instruments and Scientific Apparatus for Special Use and Applications.
- VDE 0871/6.78 Level A - RFI Suppression of Radio Frequency Equipment for Industrial, Scientific, and Medical (ISM) and Similar Purposes.
- VDE 0411 - Electronic Measuring Instruments and Automatic Controls.

DIMENSIONS:

See Figure 2-1.

WEIGHT:

Net: 15 kg (33 lb) Shipping: 16 kg (35 lb)

SECTION II INSTALLATION

2-1 INITIAL INSPECTION

2-2 Before shipment, this instrument was inspected and found to be free of mechanical and electrical defects. As soon as the instrument is unpacked, inspect for any damage that may have occurred in transit. Save all packing materials until the inspection is completed. If damage is found, file claim with carrier immediately. The Hewlett-Packard Sales and Service office should be notified as soon as possible.

2-3 Mechanical Check

2-4 This check should confirm that there are no broken controls, connectors, or indicators, that the cabinet and panel surfaces are not dented or scratched, and that the meters and plastic cover on rear panel are not scratched or cracked.

2-5 Electrical Check

2-6 Section V of this manual contains complete verification procedures for this instrument. Section III contains an abbreviated check which can be used quickly to place the unit into operation. Refer to the inside front cover of the manual for the Certification and Warranty statements.

2-7 REPACKAGING FOR SHIPMENT

2-8 To insure safe shipment of the instrument, it is recommended that the package designed for the instrument be used. The original packaging material is reusable. If it is not available, contact your local Hewlett-Packard Sales and Service office to obtain the materials. This office will also furnish the address of the nearest service office to which the instrument can be shipped. Be sure to attach a tag to the instrument specifying the owner, model number, full serial number, and service required, or a brief description of the trouble.

2-9 PREPARATION

2-10 In order to be put into service, the 6012A must be connected to an appropriate ac input power source. Also, the line voltage for which the unit is set and the rear-panel circuit breaker must be checked. Additional steps may include line-voltage conversion and rack mounting. Do not apply power to the instrument before reading paragraphs 2-15 and 2-17.

2-11 Location and Cooling

2-12 The instrument is fan cooled and must be installed

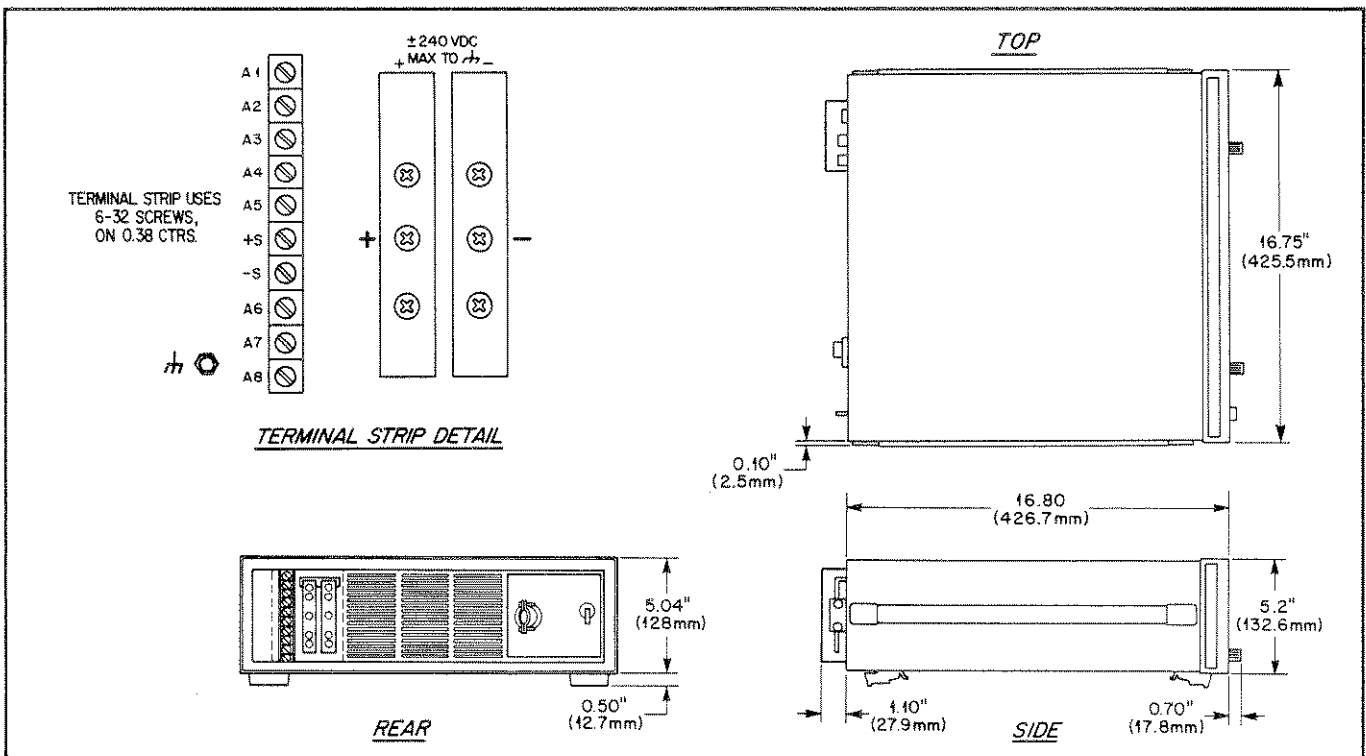

Figure 2-1. Outline Diagram

with sufficient space behind the instrument for air exhaust. It should be used in an area where the ambient temperature does not exceed +50°C.

CAUTION

The instrument should not be installed in a forced-air-cooled rack enclosure in which the static air pressure exceeds 0.06 inches of water. Static air pressure behind the instrument of greater than 0.06 inches of water will prevent proper air flow through the instrument and allow the instrument to overheat.

2-13 Outline Diagram

2-14 Figure 2-1 illustrates the outline shape and dimensions of the cabinet.

2-15 Input Power Requirements

2-16 The supply may be operated from a nominal 120V, 220V, or 240V single-phase ac power source, 48-63 Hz. The input voltage range and input current required for each of the nominal inputs are listed below.

Nominal Voltage	Line-Voltage Range	Maximum Input Current
120V	104-127	24A
220V	191-233	15A
240V	208-250	14A

2-17 Power Connection

CAUTION

Connection of this instrument to an ac power source should be done only by an electrician or other qualified personnel. Before connecting the instrument to the ac power source, check the label on the rear panel to ensure that the instrument is set for the ac voltage to be used. If necessary, the user can convert the instrument from one line voltage option to another by following the instructions in paragraph 2-25.

2-18 Input power is connected to the instrument via the AC Filter Assembly on the rear panel. The power cord must be a three-conductor cord rated for at least 85°C. For 120V operation, each conductor must be AWG #12 or larger. For 220V or 240V operation, each conductor must be AWG #14 or larger. Larger wire sizes may be required to prevent excessive voltage drop in the ac input.

WARNING

Do not use three individual wires to connect power to the instrument. The strain relief on the rear panel is designed for use only with a single three-conductor cord.

2-19 To connect input power to the instrument, proceed as follows:

- Remove four screws, one in each corner, that secure the AC Filter Assembly to the rear panel, and carefully pull the assembly away from the rear panel.
- Prepare the power cord as shown in Figure 2-2 and insert the cord through the strain relief on the AC Filter Assembly.
- Connect the longer lead to the GND terminal; connect one of the two shorter leads to the AC terminal ("hot" side of the ac line) and the other to the ACC terminal ("neutral" or "common" side of the ac line).
- Position the cord so that the strain relief grips the outer jacket of the cord, and tighten the strain relief.
- Replace the AC Filter Assembly.
- Connect the other end of the power cord to an appropriate ac power source.

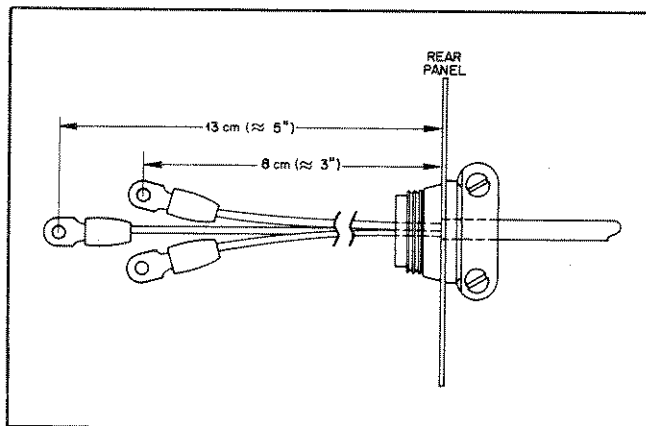

Figure 2-2. Power Cord Preparation

NOTE

Connections to the ac power line must be made in accordance with applicable electrical codes.

WARNING

For proper protection by the instrument circuit breaker, the wire connected to the AC terminal on the instrument must be connected to the AC side of the line (hot); the wire connected to the ACC terminal must be connected to the ACC side of the line (neutral or common).

To protect operating personnel, the wire connected to the GND terminal must be connected to earth ground. In no event shall this instrument be operated without an adequate ground connection.

CAUTION

Before applying power to the instrument, check to see that the rear-panel circuit breaker CB1 is in the NORMAL (up) position (breaker may trip because of rough handling during transit). If the breaker trips while power is on, or if the breaker is found to be tripped at any time for unknown reasons, refer to troubleshooting procedures in Section V.

2-20 Rack Mounting

2-21 This instrument can be rack mounted in a standard 19-inch rack panel or enclosure. All rack mounting accessories for this unit are listed in the ACCESSORIES paragraph in Section I. Complete installation instructions are included with each rack mounting kit.

2-22 AC LINE IMPEDANCE CHECK

2-23 The 6012A is designed for proper operation with line impedance typically found in ac power lines. However, if the 6012A is connected to an ac power line having high impedance combined with line voltage near the minimum specified value (e.g., 104 Vac for nominal 120 Vac), some components may overheat if the unit is asked to provide full rated output power. Such a situation might occur if the 6012A is connected to ac power an extended distance from the main ac distribution terminals and/or if the ac power wires from the main ac distribution terminals are of relatively small gauge.

2-24 Measurement of ac line voltage at the 6012A input terminals typically is not a reliable indication of the actual ac line voltage because of the peak-clipping effect of the power supply and the averaging effect of the voltmeter. Symptoms of excessive line impedance may include erratic or no output from the 6012A and/or inability of the 6012A to provide full output power. If there is reason to suspect the ac power lines to the 6012A may have high impedance, perform the following check:

WARNING

This check should be performed only by service-trained personnel who are aware of the hazards involved (for example, fire and electrical shock). Turn power supply off before making or breaking connections to power supply. Hazardous voltages are present within the unit even when power switch is turned off.

a. Remove three screws that secure top cover to rear panel; slide cover to rear and lift off.

b. Monitor unregulated +5V (pin K) with respect to common (pin E) at test connector P2 on top edge of control board (see Section VII). If +5V unregulated is less than 12 volts, 6012A is not receiving adequate ac line input. If +5V unregulated ≥ 12 volts, proceed to step c.

c. Connect variable load (Table 5-1 lists recommended load) to 6012A, turn VOLTAGE and CURRENT controls to maximum (fully CW), and adjust load for 50A output current. 6012A output voltage should be $\geq 22V$; if it is not, proceed to I_p calibration procedure in Section V. If I_p calibration is correct but unit does not provide $\geq 22V$ at 50A, 6012A is not receiving adequate ac line input.

2-25 LINE VOLTAGE OPTION CONVERSION

2-26 Line voltage conversion is accomplished by adjusting three components; the two-section line select switch S2, and jumpers W1 and W2. Figure 2-3 shows the locations of these components at the center-rear section of the main board. To convert the instrument from one line voltage option to another, proceed as follows:

a. Disconnect line cord from power source, and wait 120 seconds.

b. Remove top cover from instrument by removing three screws (one on each side and one in center) that secure cover to rear panel; slide cover to rear and lift off.

c. Use a small-blade screwdriver to set the two switch sections of S2 to match the pattern silkscreened on main board for nominal line voltage to be used. For example, to set switches for 120V operation (as illustrated in Figure 2-3), move forward switch section so that its white slot is toward front of instrument and move rearward switch section so its white slot is toward rear of instrument.

d. One end of W1 is soldered to main board; the other end has a female quick-connect terminal that fits onto one of two terminals soldered to main board. For 120V operation, W1 must be connected to terminal closer to front of instrument (as shown in Figure 2-3). For 220V or 240V operation, W1 must be connected to terminal closer to rear of instrument. Be certain that jumper is firmly mated with terminal on main board. Do not grip jumper insulation with pliers; either grip jumper wire by hand or grip jumper terminal with pliers.

e. Jumper W2 is similar to W1. For 120V operation, W2 must be connected to terminal closer to rear of instrument (as shown in Figure 2-3). For 220V or 240V operation, W2 must be connected to terminal closer to front of instrument. Be certain that jumper is firmly mated with terminal on main board. Do not grip jumper insulation with pliers; either grip jumper wire by hand or grip jumper terminal with pliers.

f. Replace top cover and mark the instrument clearly with a tag or label indicating correct line voltage to be used.

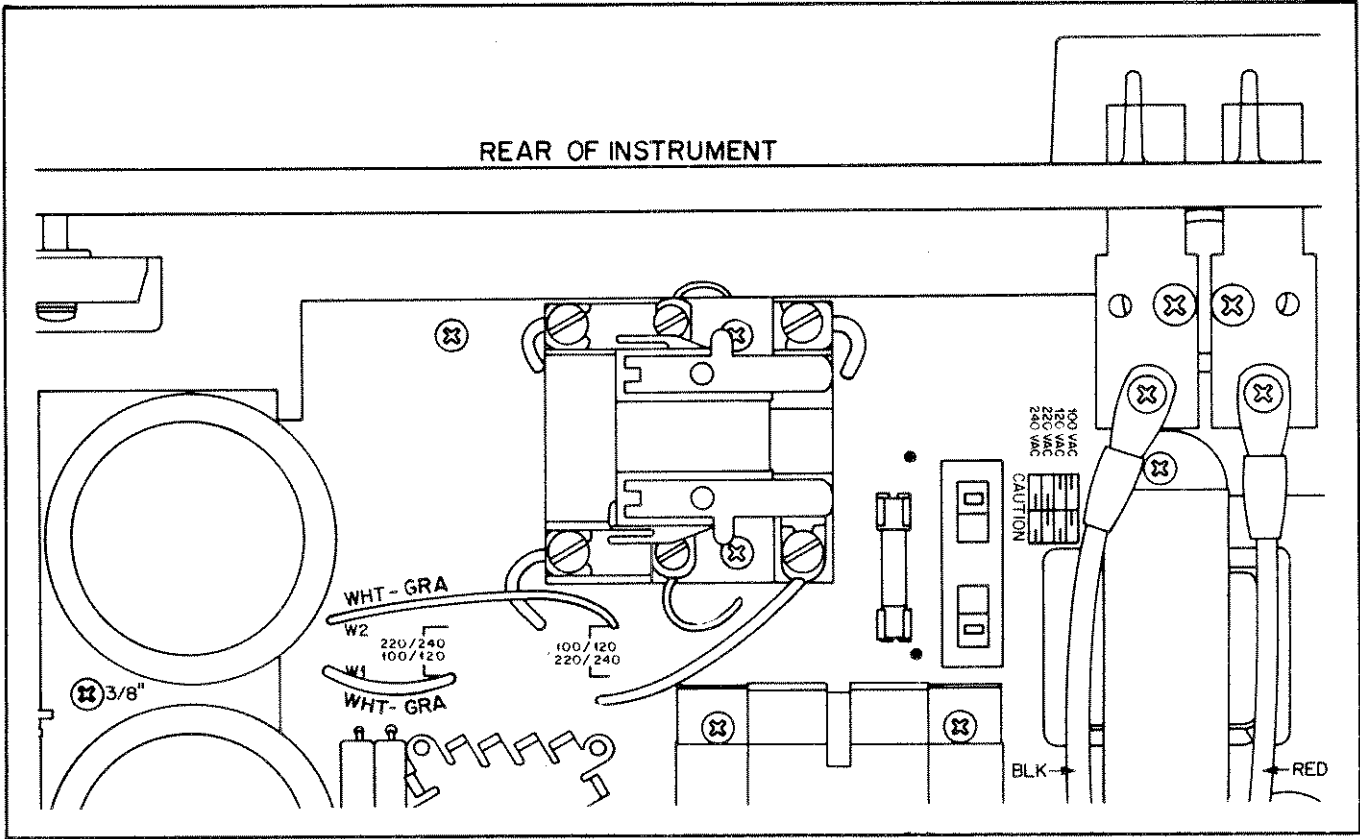

Figure 2-3. Line Voltage Conversion Components

SECTION III OPERATING INSTRUCTIONS

3-1 INTRODUCTION

3-2 This section describes the operating controls and indicators, turn-on checkout procedures, and operating procedures and considerations for the Model 6012A.

WARNING

Before the instrument is turned on, all protective earth terminals, extension cords, auto-transformers, and devices connected to it should be connected to a protective earth ground. Any interruption of the protective earth grounding will cause a potential shock hazard that could result in personal injury.

3-3 Only fuses with the required current rating and specified type should be used. Do not use short circuited fuseholders or circuit breakers. To do so could cause a shock or fire hazard.

3-4 TURN-ON CHECKOUT PROCEDURE

3-5 The following checkout procedure describes the use of the front-panel controls and indicators (see Figure 3-1) and ensures that the supply is operational. This check should be performed when the unit is first received. If the supply fails to perform properly, proceed to the troubleshooting procedures in Section V.

a. Ensure that rear terminal board straps are connected as shown in Figure 3-3, but do not connect load. Check that rear-panel label indicates unit is set for line voltage to be used. If it is not, refer to Section II, Line Voltage Option Conversion. If unit is equipped with System Option 002 ensure that option cable is disconnected from rear-panel option connector before proceeding.

b. Ensure that CURRENT control (8) is rotated clockwise at least two turns and OVP ADJUST potentiometer (10) (screwdriver adjust) is fully clockwise.

c. Press pushbutton LINE switch (1) on (pushbutton in) and observe that green LINE indicator turns on and that fan operates.

d. Turn VOLTAGE control (3) through output voltage range of unit as indicated on voltmeter (12). Green VOLTAGE light (4) should be lit across entire range indicating that supply is in constant voltage mode.

e. Check overvoltage circuit by turning OVP ADJUST control counterclockwise until output voltage drops. Output voltage should drop to ≈ 0 volts and red OVP (9) and OUTPUT UNREGULATED (5) indicators should light.

f. Reset overvoltage circuit by returning OVP control to maximum clockwise position and turning supply off for at least two seconds and then back on. Output voltage should return to value set in step d.

g. To check constant current circuit, turn off supply and connect short (AWG #8 or larger) across + and - output terminals on rear panel. Ensure that VOLTAGE control is rotated at least two turns clockwise.

h. Turn supply back on and rotate CURRENT control (8) through output current range of unit as indicated on ammeter (11). Green CURRENT light (7) should be on across entire range indicating that supply is in constant current mode.

i. Turn off supply, remove short from output, and read remainder of operating instructions before connecting actual load to supply.

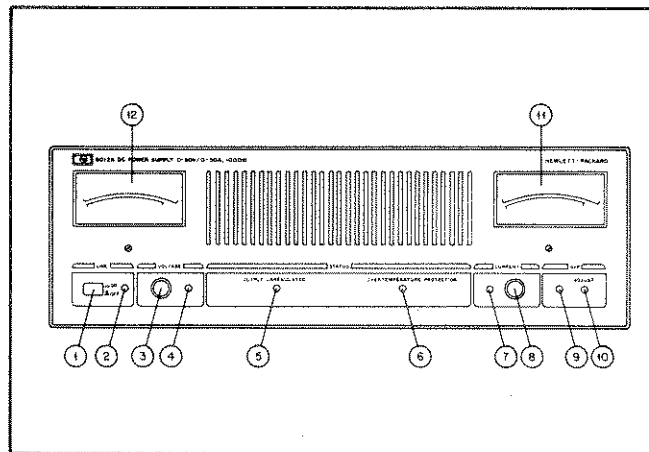

Figure 3-1. Front Panel Controls and Indicators

3-6 CONNECTING THE LOAD

3-7 Load connections to the power supply are made at rear-panel + and - bus bars. Wires may be connected to any of the three pairs of connecting screws on the bus bars. Stranded wires should be terminated with an appropriate size terminal. To satisfy safety requirements, the wires to the load should be *at least* heavy enough not to overheat while carrying the power supply output current that would flow if *the load were shorted*. Table 3-1 lists some single wire sizes and two-wire combinations, and the current-carrying capacity they provide. *Generally, heavier wire than that listed in Table 3-1 is required to obtain good regulation at the load.* If the load regulation is critical, use remote voltage sensing (refer to Paragraph 3-37).

Table 3-1. Copper Wire Current-Carrying Capacity

Wire Type (note 1)	20A	30A	40A	50A
80°C Stranded	1 - #12 2 - #14	1 - #10 2 - #12	1 - #8 2 - #12	1 - #8 2 - #10
80°C Solid	1 - #10 2 - #14	1 - #8 2 - #12	1 - #6 2 - #10	1 - #6 2 - #8
105°C Stranded	1 - #14 2 - #16	1 - #12 2 - #14	1 - #10 2 - #12	1 - #10 2 - #12
105°C Solid	1 - #12 2 - #16	1 - #10 2 - #12	1 - #8 2 - #10	1 - #6 2 - #10

Notes:

1. Maximum allowable conductor temperature based on 60°C ambient temperature plus 20°C or 45°C temperature rise due to continuous dc current.
2. Capacities based on assumption that + and - leads are twisted together to reduce noise pickup.
3. Other wire combinations can also be used to provide the capacities listed in this table. Note that increasing the number of conductors in a bundle does not increase the current-carrying capacity by the number of conductors. (EG: Two #10 wires bundled together provide only 1.89 times the current-carrying capacity of one #10 wire.)
4. Current-carrying capacity of aluminum wire is approximately 84% of that listed for copper wire.

3-8 The bus bars and terminal strip are protected by a high-impact plastic cover, which is secured to the unit with two 7/8-inch #6-32 screws. Wires to the bus bars and terminal strip pass through slots in the cover. Be certain to replace the cover after making connections.

3-9 If multiple loads are connected to one supply, each load should be connected to the supply's output terminals using separate pairs of connecting wires. This minimizes mutual coupling effects between loads and takes full advantage of the supply's low output impedance. Each pair of connecting wires should be as short as possible and twisted or shielded to reduce noise pickup.

3-10 If load considerations require the use of output distribution terminals that are located remotely from the supply, then the power supply output terminals should be connected to the remote distribution terminals by a pair of twisted or shielded wires and each load should be separately connected to the remote distribution terminals. Remote voltage sensing is required under these circumstances (Paragraph 3-37).

3-11 Either positive or negative voltages can be obtained from this supply by grounding one of the output terminals. It is best to avoid grounding the output at any point other than the power supply output terminals to avoid regulation problems caused by common-mode current flowing through the load leads to ground. Always use two wires to connect the load to the supply regardless of where or how the system is grounded. Never ground the system at more than one point. This supply can be operated with either output terminal up to ±240 volts dc (including output voltage) from ground.

3-12 The PARD specifications in Table 1-1 apply at the power supply output terminals. However, noise spikes induced in the load leads at or near the load may affect the load although the spikes are inductively isolated from the power supply. To minimize voltage spikes at the load, connect a bypass capacitor as shown in Figure 3-2. With this setup, peak-peak noise at the load can actually be reduced to a level well below the value specified at the 6012A output terminals.

3-13 Before operating the power supply, read the paragraphs in this section concerning protective circuits, normal operating mode, and any sections of alternate operating modes relevant to your application.

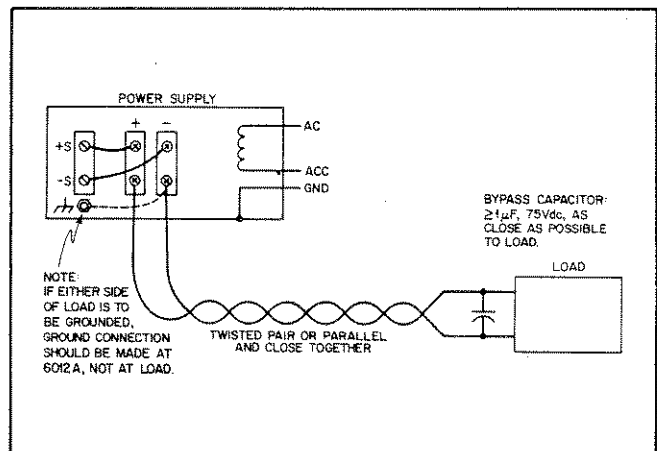

Figure 3-2. Connecting a Bypass Capacitor

3-14 PROTECTIVE CIRCUITS

3-15 Protective circuits within the instrument may limit or turn off the output in case of abnormal conditions. The cause for the protective action can be determined by observing the front-panel indicators and meters. An overrange condition is indicated by the OUTPUT UNREGULATED indicator on, all other indicators off, and the VOLTS and AMPERES meters reading relatively high. An overvoltage condition is indicated by both the OVP and OUTPUT UNREGULATED indicators on, all other indicators off, and the meters reading near zero. An overtemperature condition is indicated by both the OVERTEMPERATURE PROTECTION and OUTPUT UNREGULATED indicators on, all other indicators off, and the meters dropping toward zero from the readings that existed when the overtemperature condition occurred. If the ac input voltage drops below approximately 70% of nominal, the bias voltage detector will shut down the output. In this case, the OUTPUT UNREGULATED indicator is on, all other indicators are off, and the meters read zero immediately.

3-16 OPERATING MODES

3-17 This power supply is designed so that its mode of operation can be selected by making strapping connections on its rear panel. Normal operating mode for this power supply uses local programming of the output voltage and current via the front-panel VOLTAGE and CURRENT controls, and local sensing of the output voltage. Alternate operating modes allow use of remote programming, remote voltage sensing, and multiple power supply combinations.

3-18 The following paragraphs first describe operating considerations with the normal operating mode, using the strapping pattern as it is connected at the factory. Later paragraphs cover alternate operating modes. The operating considerations described with normal mode, such as constant voltage/constant current crossover, overrange, constant voltage and constant current operation, and overvoltage protection apply to the alternate modes as well as to normal mode. More theoretical descriptions regarding the operational features of power supplies in general are given in the DC Power Supply Handbook, Application Note 90B (available at no charge from your local Hewlett-Packard Sales Office).

3-19 NORMAL OPERATING MODE

3-20 The power supply was shipped with the proper rear-panel strapping connections made for constant voltage/constant current operation with local sensing and local programming. This strapping pattern is illustrated in Figure 3-3. By means of the front-panel voltage and current controls, the operator selects either a constant voltage or a constant current output as described in Paragraphs 3-27 or 3-29. Whether the supply functions in the constant voltage or constant current mode depends on the settings of the VOLTAGE and CURRENT controls and on the value of the load resistance.

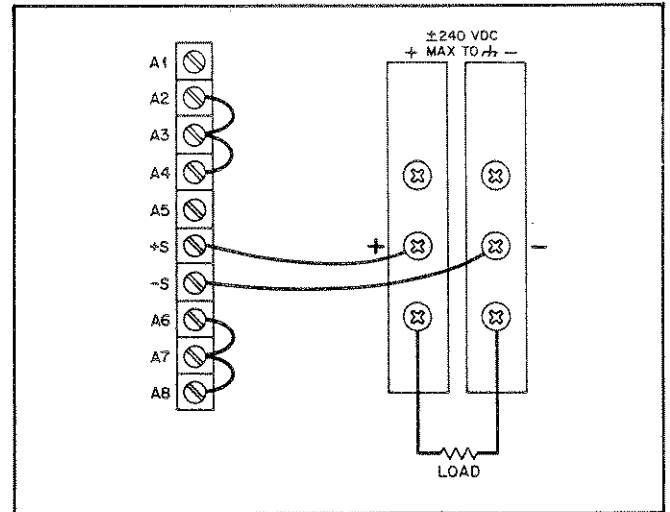

Figure 3-3. Normal Strapping

3-21 Figure 3-4 shows the overall output range of the supply, with three sample operating loci. Locus 1 is established with a VOLTAGE setting of 20V and a CURRENT setting of 8A. For any values of load resistance greater than the crossover value of 2.5 ohms, the supply operates in constant voltage mode. For values of load resistance less than the crossover value, the supply operates in constant current mode. The transition occurs smoothly and automatically; no switches need be operated or connections changed. The front-panel VOLTAGE and CURRENT lights indicate which mode is operating.

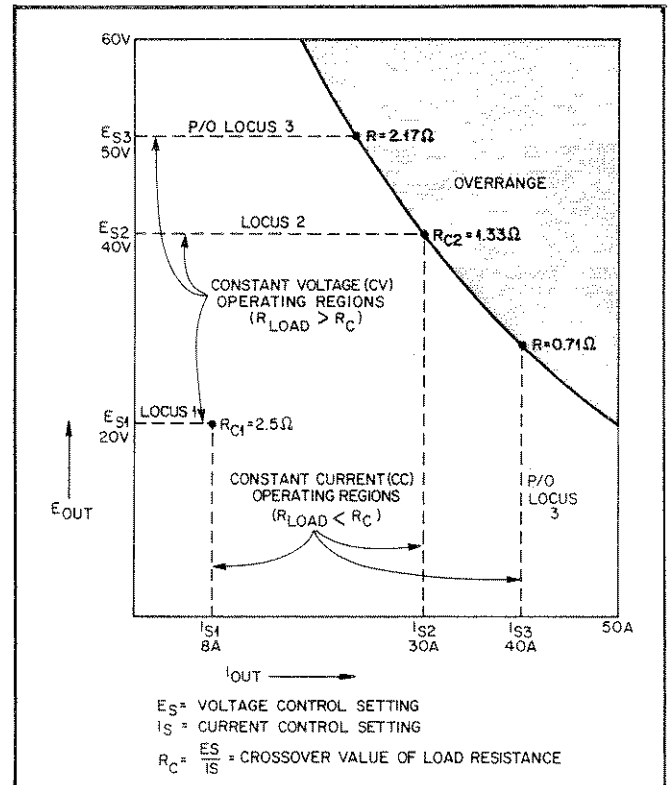

Figure 3-4. Overall Output Range with Three Sample Operating Loci

3-22 Locus 2 is established with VOLTAGE setting of 40V and a CURRENT setting of 30A. Its crossover load resistance is 1.3 ohms, and lies on the rated-output-power boundary.

3-23 A rectangular operating locus will be established for all voltage and current settings within the rated-output-power boundary, and the load resistance determines where on that locus the power supply operates. However, if the VOLTAGE and CURRENT controls are set so that the boundary can be exceeded, as in locus 3, the supply will go into overrange if the load resistance falls within a critical band (refer to next paragraph).

3-24 **Overrange.** The supply will be driven into overrange (shaded area of Figure 3-4) if the VOLTAGE and CURRENT controls are set above the output power rating and the load resistance falls within a critical band. For example, assume that the operator sets the VOLTAGE control at 50V and the CURRENT control at 40A, as in locus 3 on Figure 3-4. For all load resistances above 2.2 ohms (which is the critical value) the supply would operate normally in the constant voltage mode. If the load resistance were to fall much below 2.2 ohms, however, the supply would be forced into overrange. If the load resistance continued to decrease to a 0.7 ohm value, the supply would automatically come out of overrange and into the constant current mode at the 40A, 25V point. (The supply will probably go out of regulation while operating in the overrange region, refer to Paragraph 3-26.)

3-25 Anytime the supply operates in overrange, the VOLTAGE and CURRENT indicators turn off and the OUTPUT UNREGULATED indicator lights. The VOLTS and AMPERES meters indicate the voltage and current being supplied to the output. (The product of the two readings will exceed 1000 watts.) Paragraph 3-14 identifies conditions other than overrange which cause the OUTPUT UNREGULATED indicator to light.

3-26 The supply can operate in the overrange region (beyond the rated-output-power boundary) for sustained periods without being damaged. However, the supply is not guaranteed to meet specifications in overrange. Output ripple increases substantially and regulation is seriously degraded. As an operator aid, the maximum available load current for each voltage setting is indicated on a secondary scale of the voltmeter. Similarly, the maximum available load voltage for each current setting is indicated on the ammeter.

NOTE

Under certain conditions of line and load, it is possible for the supply to provide more than rated output power and still maintain regulation. If this occurs, the unit will operate normally and the OUTPUT UNREGULATED indicator will be off. However, the slightest change in either line or load may cause the unit to go out of regulation. Operation of the unit beyond the rated-output-power boundary is not recommended under any circumstance.

3-27 Constant Voltage Operation

3-28 To adjust the supply for constant voltage operation:
a. Turn on supply and, with output terminals open, adjust the VOLTAGE control for the desired output voltage. Then turn power off.

b. Connect a short across the rear-panel + and - output terminals, restore power, and adjust the CURRENT control for the desired maximum output current. Then turn power off and remove the short. If a load change causes this current limit to be exceeded, the supply automatically crosses over to constant current operation at this preset current limit and the output voltage drops proportionately. In setting the current limit, make an adequate allowance for high peak currents that could cause unwanted crossover.

3-29 Constant Current Operation

3-30 To adjust the supply for constant current operation:

a. With supply turned off, connect a short across the rear-panel + and - output terminals, turn the power on, and adjust the CURRENT control for the desired output current.

b. Turn power off, open the output terminals and adjust the VOLTAGE control for the desired maximum output voltage. If a load change causes this voltage limit to be exceeded, the supply automatically crosses over to constant voltage operation at this preset voltage limit and the output current drops proportionately. In setting the voltage limit, make an adequate allowance for high peak voltages that could cause unwanted crossover.

3-31 Overvoltage Protection (OVP)

3-32 **Adjustment.** The overvoltage trip point is adjusted with the single-turn OVP ADJUST screwdriver control on the front panel. The approximate trip voltage range for this unit is from two volts to 63 volts. When the overvoltage protection circuit trips, the supply is inhibited and delivers no output power; the OVP and OUTPUT UNREGULATED indicators on the front panel light. Rotating the control clockwise sets the trip voltage higher. (It is set to maximum at the factory.)

3-33 When adjusting the OVP trip point, the possibility of false tripping must be considered. If the trip voltage is set too close to the supply's operating voltage, a transient in the output would falsely trip the OVP. For this reason it is recommended that the OVP trip voltage be set higher than the output voltage by at least 1.5 volts + 1% of the output voltage. To adjust the OVP trip voltage, proceed as follows:

a. With OVP ADJUST control fully clockwise, no load connected, turn on supply.

b. Set output VOLTAGE control to desired trip voltage.

c. Turn OVP ADJUST control counterclockwise until OVP circuit trips; red OVP indicator lights and output voltage falls to zero.

d. Turn off supply and turn down output voltage.

e. Turn supply back on and set desired output voltage.

3-34 **Resetting the OVP Circuit.** If the OVP circuit trips during normal operation, the ac LINE switch must be turned

off for at least two seconds and then back on to reset the circuit. If the OVP circuit trips continuously, check the load and/or the trip point setting. If the supply does not operate properly after the OVP circuit is reset, proceed to troubleshooting in Section V.

3-35 ALTERNATE OPERATING MODES

3-36 The alternate operating modes discussed in the following paragraphs include: remote voltage sensing, remote programming, auto-parallel operation, auto-series operation, and auto-tracking operation. By changing the rear-panel strapping pattern according to the instructions which follow, the supply can be operated in any of the modes listed above.

WARNING

Disconnect input ac power before changing any rear-panel connections and make certain all wires and straps are properly connected and terminal strip screws are securely tightened before reapplying power.

3-37 Remote Voltage Sensing

3-38 Because of the unavoidable voltage drop developed in the load leads, the normal strapping pattern shown in Figure 3-3 will not provide the best possible voltage regulation at the load. The remote sensing connections shown in Figure 3-5 improve the voltage regulation at the load by monitoring the voltage there instead of at the supply's output terminals. (The advantages of remote sensing apply only during constant voltage operation.) When using remote sensing, turn off the power supply before changing the rear-panel straps, sense leads, or load leads. The following paragraphs discuss some precautions that should be observed when making a remote sensing installation.

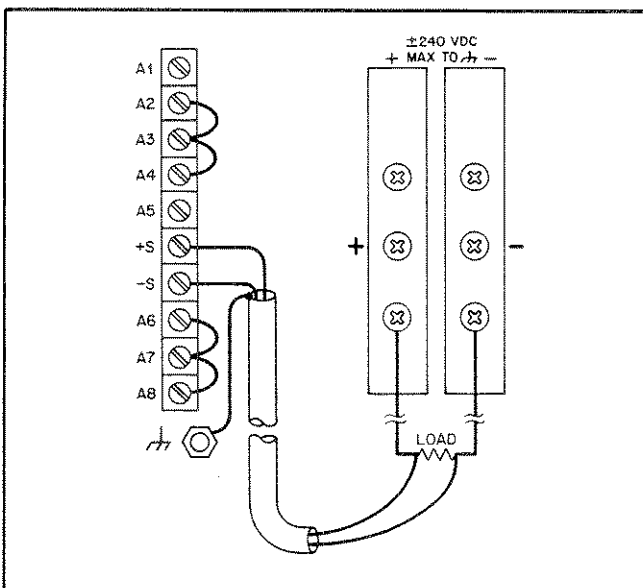

Figure 3-5. Remote Sensing

3-39 The load leads should be of the heaviest practicable wire gauge, at least heavy enough to limit the voltage drop in each lead to 0.5 volts. The power supply has been designed to minimize the effects of long load lead inductance, but best results will be obtained by using the shortest load leads practical.

NOTE

Because the OVP circuit monitors voltage at the rear terminals and there is an unavoidable voltage drop in the load leads, it may be necessary to readjust the OVP trip point in remote sensing mode.

3-40 Since the sensing leads carry only a few milliamperes, the wires used for sensing can be much lighter than the load leads (AWG #22 is generally adequate), but they should be a shielded, twisted pair to minimize the pickup of external noise. Any noise picked up on the sensing leads will appear at the supply's output, and CV load regulation may be adversely affected. The shield should be grounded at one end only and should not be used as one of the sensing conductors. The sensing leads should be connected as close to the load as possible.

3-41 The sensing leads are part of the supply's programming circuit, so they should be connected in such a way as to make it unlikely that they might inadvertently become open circuited. If the sense leads open during operation, it is possible that the load voltage will rise above its programmed value. Therefore, it is recommended that no switch, relay, or connector contacts be included in the remote sensing path.

3-42 Remote Programming

3-43 The output voltage and/or current of the power supply can be remotely controlled by external resistance, voltage, or current sink. Programming can be accomplished via the standard rear-panel screw-on terminals or via the option connector on units equipped with System Option 002. Standard programming is described in this section; programming with System Option 002 is described in Appendix A.

3-44 For resistance programming, a variable resistor can control the output over its entire range. To restrict control of the variable resistor to a limited portion of the output range, fixed resistors can be connected in series and/or parallel with the variable resistor. Alternatively, a switch can be used to select fixed values of programming resistance to obtain a set of discrete voltages or currents. (It is recommended that make-before-break switch contacts be used, to avoid producing the output voltage spikes caused by momentarily opening the programming terminals. The output voltage will drop momentarily while both sets of switch contacts are closed. If break-before-make switch contacts are used, the output voltage will rise momentarily while both sets of switch contacts are open. Depending on the switching speed, this may trip the OVP.)

3-45 To maintain the temperature and stability specifications of the supply, any resistors used for programming must be stable, low-noise resistors with a temperature coefficient of less than 25ppm per °C and a power rating at least 10 times what they will actually dissipate.

3-46 Both voltage and current outputs can also be controlled by a voltage source. A voltage source of 0 to 5 volts programs the output from zero to full scale. Voltage sources of more than 5 volts can be scaled down to the proper range.

3-47 Current programming of both voltage and current outputs is possible also. With current programming, the supply's own constant current sources are used to provide current through an external resistance. A controllable current sink, such as a DAC, in parallel with the external resistor sinks a controllable percentage of the current around the resistance. The remaining current flows through the external resistance and develops a voltage that programs the power supply. The DAC used for current programming must be capable of sinking 0-2 mA and must have a compliance voltage range of 0 to +5V.

NOTE

The 6012A constant-current source must be calibrated to provide exactly 2 mA and the DAC must sink exactly 2 mA when it is programmed for zero output. Otherwise, there will be a fixed error that will be relatively large compared to the zero output desired. The DAC must have a very low temperature coefficient to avoid drifting. Most DACs have a temperature-compensating resistor through which they sink current, but this compensation is not effective when used with an external resistor such as that used when current programming the power supply. Both of these error possibilities, mis-calibration and temperature drift, are most pronounced when programming zero or near zero output (volts or amperes).

For these reasons and for reasons given in the current-programming paragraphs, it is recommended that current programming of either output voltage or output current be accomplished via System Option 002.

3-48 Connecting a supply for remote programming of output voltage or current disables the corresponding front-panel controls.

3-49 The following paragraphs discuss in greater detail the methods of remotely programming the output voltage or current using either a resistance, voltage, or current input. Whichever method is used, the wires connecting the programming terminals of the supply to the remote programming device must be shielded to reduce noise pickup. The outer shield of the cable should not be used as a conductor, and

should be connected to ground at one end only. (For clarity, Figures 3-6 through 3-13 do not show shielded cable.)

3-50 Although the following connection drawings (Figures 3-6 through 3-13) show the supply strapped for local sensing, remote programming and remote voltage sensing do not interact and may be used simultaneously.

3-51 Resistance Programming of Output Voltage. The rear-panel connections shown in Figure 3-6 allow the output voltage to be varied by using an external resistor to program the supply. A programming resistor variable from 0 to 2500 ohms produces a proportional output voltage from zero to full scale. Note that fixed resistors may be connected in series and/or parallel with the variable programming resistor to set lower and/or upper output voltage limits. The resultant programming resistance is the sum of the series/parallel resistor combination, and must be between 0 and 2500 ohms.

3-52 For example, a 1250 ohm resistor connected in series with the variable programming resistor will set the lower limit for output voltage at one-half full scale, i.e., 30 volts. A 1250 ohm resistor connected in parallel with a 2500 ohm variable programming resistor will set the upper limit for output voltage at 20 volts. Connecting the parallel resistor directly from terminal A7 to -S will limit the output voltage even if the remote programming leads become open circuited.

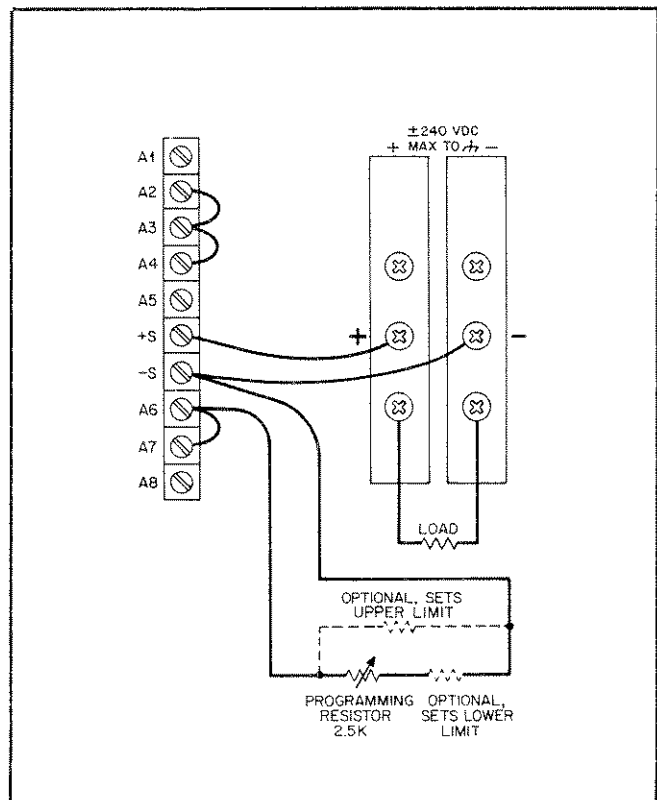

Figure 3-6. Resistance Programming of Output Voltage

NOTE

If the programming terminals (A7 to -S) become open circuited during resistance programming, the output voltage will tend to rise above rating. The supply will not be damaged if this occurs, but the OVP trip point should be properly adjusted to protect the user's load.

3-53 Voltage Programming of Output Voltage. The rear-panel connections shown in Figure 3-7 allows the output voltage to be varied by using an external voltage source to program the supply. A voltage source variable from 0 to +5 volts produces a proportional output voltage from zero to full scale. The load on the programming source is less than 5 μ A.

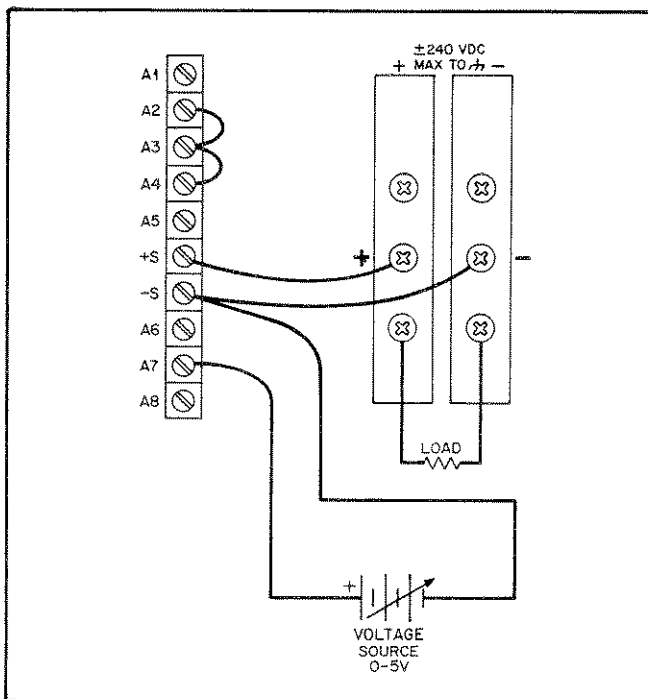

Figure 3-7. Voltage Programming of Output Voltage

3-54 Scaled Voltage Programming of Output Voltage. The rear-panel connections shown in Figure 3-8 allow the output voltage to be varied by using an external voltage source of more than 5 volts to program the supply. The ratio of the resistance values in the voltage divider must be selected so that the voltage at the center tap of the divider, A7, varies from 0 to 5 volts as the programming voltage source varies from zero to maximum.

3-55 The total resistance of the voltage divider should be as small as practical without excessively loading the external voltage source. This minimizes degrading the programming speed, offset, and drift specifications. The voltage divider appears as a parallel pair of resistors to the power supply. An equivalent resistance of 5k will approximately double the up-

programming time. An equivalent resistance of less than 1k will make the degradation unnoticeable in most applications.

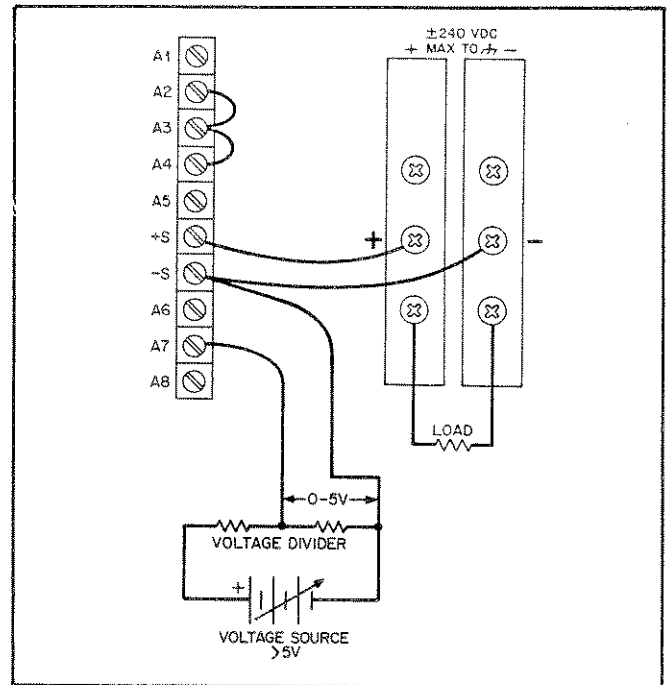

Figure 3-8. Scaled Voltage Programming of Output Voltage

3-56 Current Programming of Output Voltage. The rear-panel connections shown in Figure 3-9 allow the output voltage to be varied by using an external current sink to program the supply. In this configuration the supply's own constant current source is used to develop a voltage across the resistor. A current sink, such as a DAC, connected in parallel with the resistor sinks part or all of the current, and thereby determines the voltage developed across the resistor. (See note following Paragraph 3-47.) A current sink variable from 2 mA to 0 mA produces an inversely proportional output voltage from zero to full scale. Many DACs include a sign-change bit, so that a zero digital input to the DAC will produce a 0 volt output from the power supply, and a maximum digital input to the DAC will produce a full scale output from the power supply. Note that the VOLTAGE control potentiometer can be used in place of the external resistor by connecting A8 and A7 in place of the 2.5k resistor connected between A7 and -S.

CAUTION

If the DAC is turned off or the program leads open, the output voltage will tend to rise above rating. The supply will not be damaged if this occurs, but the OVP trip point should be properly adjusted to protect the user's load.

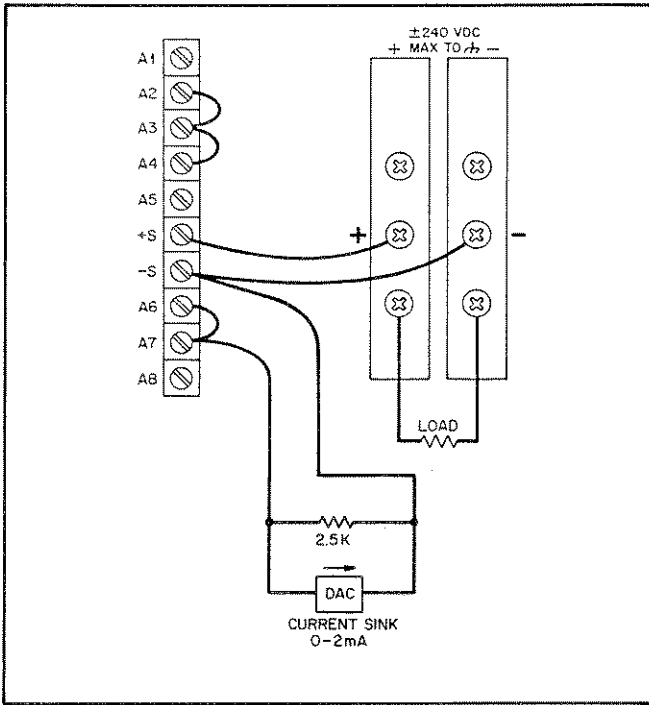

Figure 3-9. Current Programming of Output Voltage

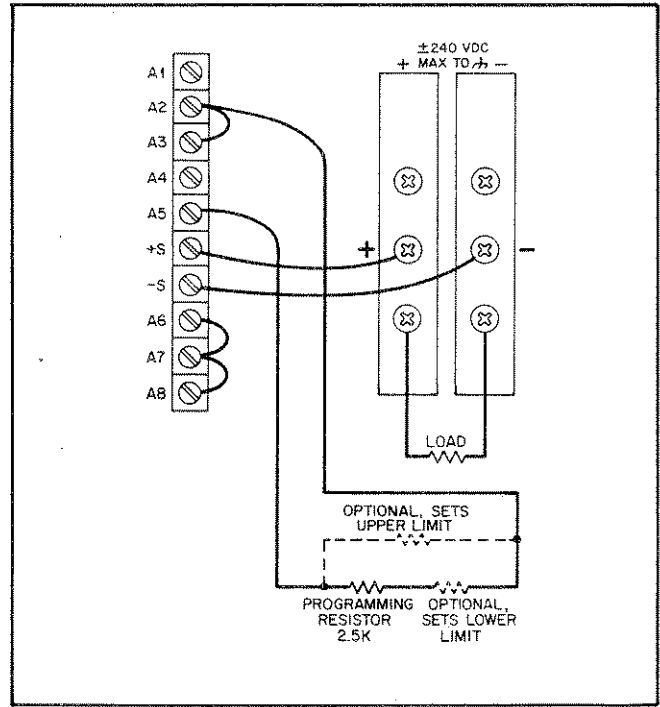

Figure 3-10. Resistance Programming of Output Current

3-57 Resistance Programming of Output Current. The rear-panel connections shown in Figure 3-10 allow the output current to be varied by using an external resistor to program the supply. The discussion in Paragraphs 3-51 and 3-52 for constant voltage operation also applies for constant current operation.

3-58 Voltage Programming of Output Current. The rear-panel connections shown in Figure 3-11 allow the output current to be varied by using an external voltage source to program the supply. The discussion in Paragraph 3-53 for constant voltage operation also applies for constant current operation.

CAUTION

If the programming terminals (A2 to A5) become open circuited during resistance programming, the output current will tend to rise above rating. The supply will not be damaged if this occurs, but the user's load may be damaged. If there is a possibility that the programming leads may be opened, it is suggested that the optional resistor be connected directly across terminals A5 and A2, as shown in Figure 3-10. The value of this resistor should be selected to limit the output current to the maximum that the load can handle without damage. For example, if the load can handle 25 amperes (one-half of full scale), a 1250 ohm resistor should be connected from A5 to A2. Remember that the resistance value actually programming the supply is the parallel combination of the programming resistor and the optional resistor.

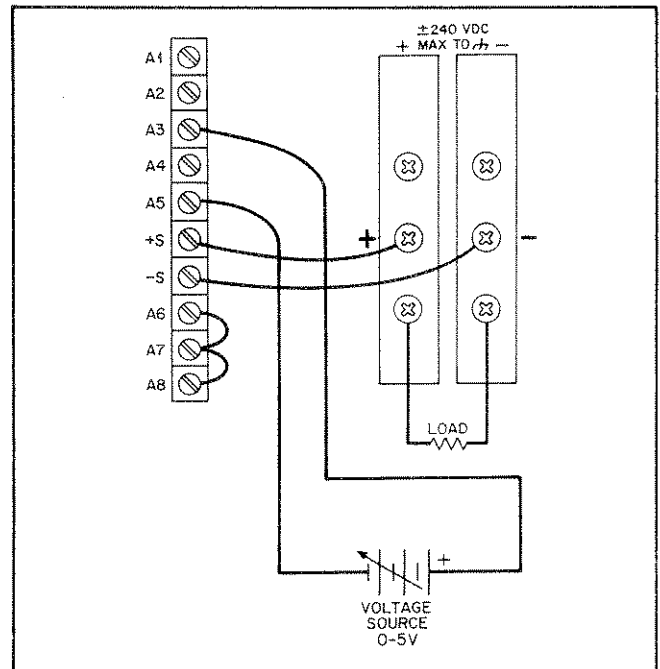

Figure 3-11. Voltage Programming of Output Current

3-59 Scaled Voltage Programming of Output Current. The rear-panel connections shown in Figure 3-12 allow the output current to be varied by using an external voltage source of more than 5 volts to program the supply. The discussion in Paragraphs 3-54 and 3-55 for constant voltage operation also applies for constant current operation.

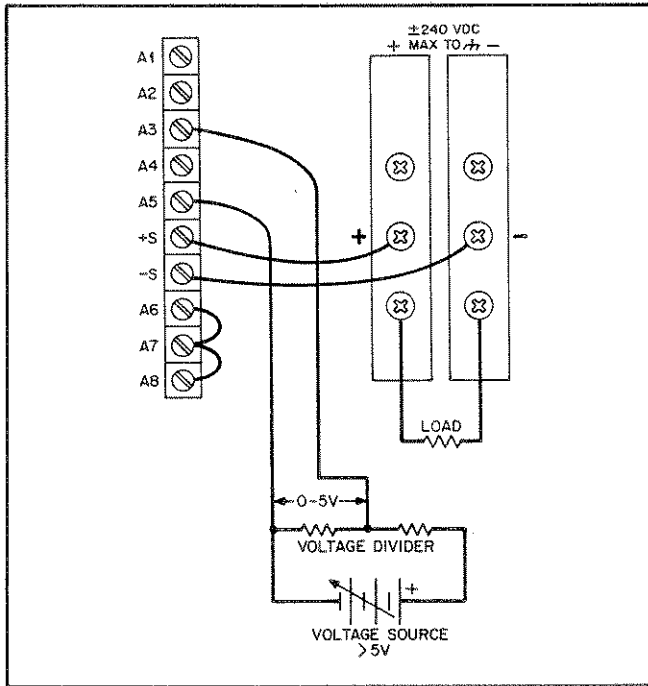

Figure 3-12. Scaled Voltage Programming of Output Current

3-60 Current Programming of Output Current. The rear-panel connections shown in Figure 3-13 allow the output current to be varied by using an external current sink to program the supply. (See note following Paragraph 3-47.) The discussion in Paragraph 3-56 for constant voltage operation also applies for constant current operation, except that the CURRENT control can be used in place of the external resistor by connecting A4 to A3 in place of the 2.5k resistor connected between A3 and A5.

CAUTION

If the DAC is turned off or the program leads open, the output current will tend to rise above rating. The supply will not be damaged if this occurs, but the VOLTAGE control should be adjusted such that the supply will switch to CV mode once the output current reaches the highest level the load can absorb and/or the OVP ADJUST should be set to shut down the supply.

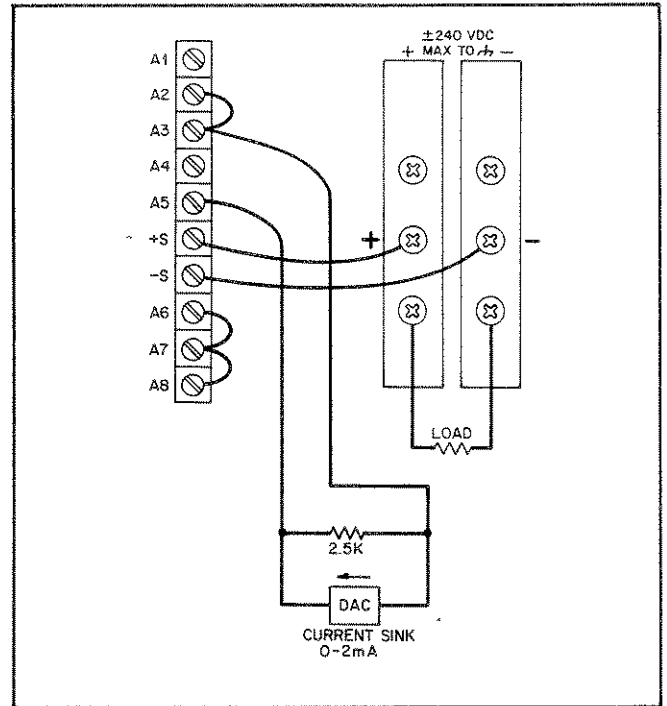

Figure 3-13. Current Programming of Output Current

3-61 Auto-Parallel Operation

3-62 Figure 3-14 shows the rear-panel interconnections required to auto-parallel two or more units. This mode of operation provides a greater current capability than can be obtained from a single supply, while ensuring that each supply will share the load proportionally to its own total power capability under all load conditions. For example, if a 1000W supply and a 200W supply were auto-paralleled, the 1000W supply would provide 5/6 the total current and the 200W supply would provide 1/6 the total current. The 6012A can be auto-paralleled only with other autoranging units, or with units that have current-monitoring output signals that are internally referenced to the - output and equal to +5V at maximum rated current output. Any number of supplies may be connected in auto-parallel.

NOTE

Use wire of equal length and gauge to connect each auto-paralleled supply to the load. Load sharing will not be equal unless the leads connecting each supply to the load are equal in resistance. If it is impractical to run leads from each supply to the load because of distance between the supplies and the load, leads of equal length should be run from each supply to common distribution terminals, with a single pair of leads run from the distribution terminals to the load.

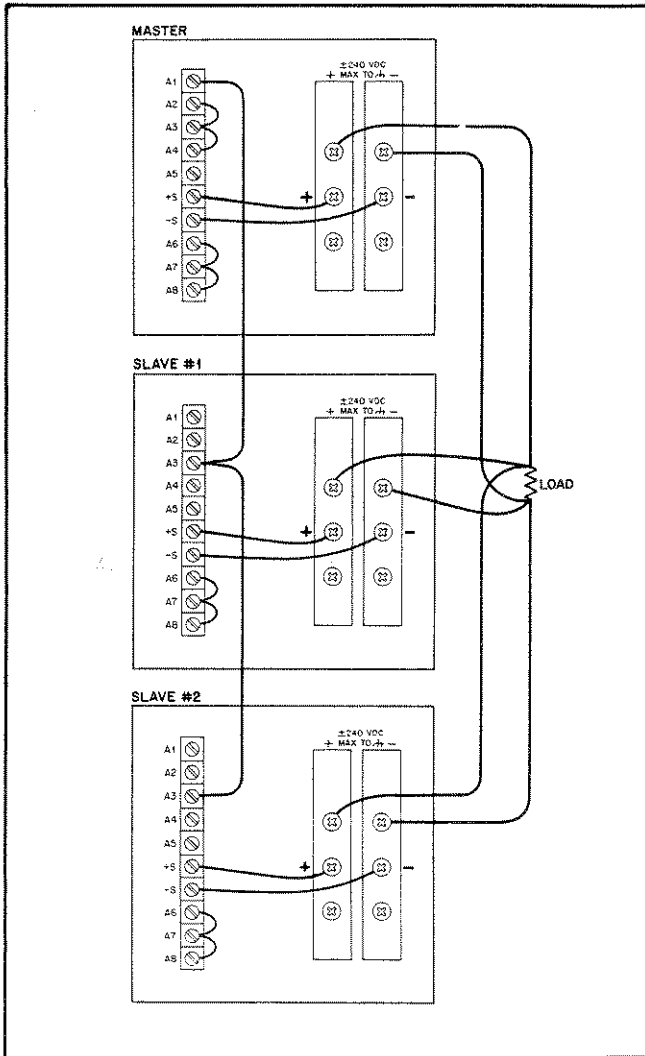

Figure 3-14. Auto-Parallel Operation

3-63 Setting the Voltage and Current Controls. The auto-parallel combination of supplies behaves as if it were a single constant voltage/constant current supply controlled by the voltage and current controls of the master supply. The current controls of the slaves are disabled. The voltage controls of the slaves should be set above the desired output voltage to avoid interference with the master.

3-64 Overvoltage Protection in Auto-Parallel. Adjust the OVP trip point at the master supply. The slave supply OVP control(s) may be set to the same level or to maximum (fully clockwise) to disable them. If the master OVP trips, the master will program the slaves to zero output. If a slave OVP trips, it shuts down only that slave; the other units supply more current until the master switches to CC mode.

3-65 Auto-Parallel with Remote Sensing. To combine auto-parallel operation with remote sensing, connect the supply as described above but remove the +S and -S jumpers from the master supply and connect the +S and -S terminals directly to the + and - ends of the load. Observe the precautions outlined under Paragraph 3-37.

3-66 Auto-Parallel with Remote Programming. The output voltage and/or current of an auto-parallel combination can be remotely programmed. Remote programming connections are made to the master supply. Observe all precautions outlined in the remote programming paragraphs. Simultaneous use of remote sensing and remote programming is also possible during auto-parallel operation.

NOTE

Because only the master can down-program the output of an auto-parallel combination, down-programming speed will be reduced under no-load conditions.

3-67 Auto-Series Operation

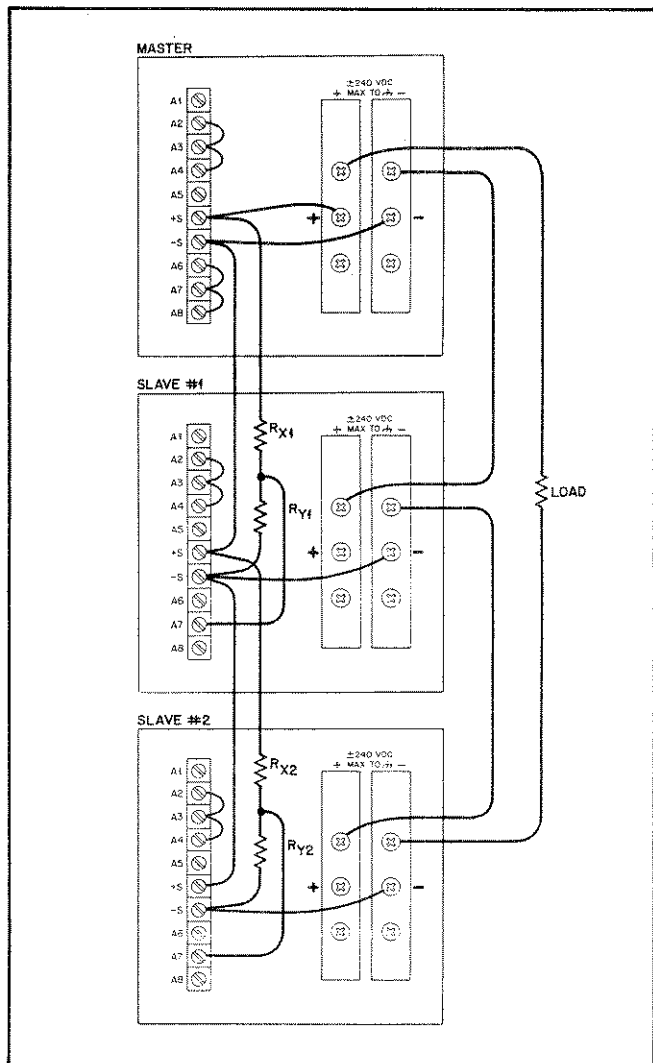

Figure 3-15. Auto-Series Operation

3-68 Figures 3-15 and 3-16 show the rear-panel interconnections required to operate two or more supplies in auto-

series. This mode of operation provides a greater voltage capability than can be obtained from a single supply. As many as four supplies can be connected in auto-series in the configuration shown in Figure 3-15, and as many as eight supplies can be connected if the power supply combination and load are center-tapped as in Figure 3-16 (with no more than four supplies on each side of the center tap). Either configuration allows all the supplies to be programmed simultaneously by the voltage and current controls of the master supply. The master supply must always be the one at the positive end of the series combination. Any point of the output can be grounded if desired, as long as no other point in the output is more than 240 volts (including output voltage) from ground.

3-69 The output voltage of each slave supply varies in direct proportion to that of the master. The ratio of each slave's output voltage to the master's is established by the ratio of the resistors in the voltage divider connected between the + Sense of the master and the - S Sense of the slave.

3-70 Any power supply capable of auto-series operation can be used in the auto-series combination. The supply with the lowest current rating limits the maximum output current of the combination. Any well-regulated, variable-output supply can be used as the master.

3-71 In applications in which coordinated positive and negative voltages are required, center tapping the supply combination and load as shown in Figure 3-16 allows simultaneous proportional control of both supply voltages.

CAUTION

If more than four supplies are connected together in an auto-series combination, be certain that neither the more positive end nor the more negative end of the auto-series combination is more than 240 volts (including output voltage) from ground.

3-72 **Setting the Voltage and Current Controls.** The auto-series combination of supplies behaves as if it were a single constant voltage/constant current supply controlled by the voltage and current controls of the master supply. The voltage controls of the slaves are disabled. The current controls of the slaves should be set above the desired output current to avoid having a slave switch to CC mode.

NOTE

The current controls of the slave supplies can be disabled by disconnecting the straps between the A3 and A4 terminals and connecting a resistor between A3 and A5 on each slave. The resistor value should be chosen to program a current greater than the desired output current. (See Paragraph 3-57.)

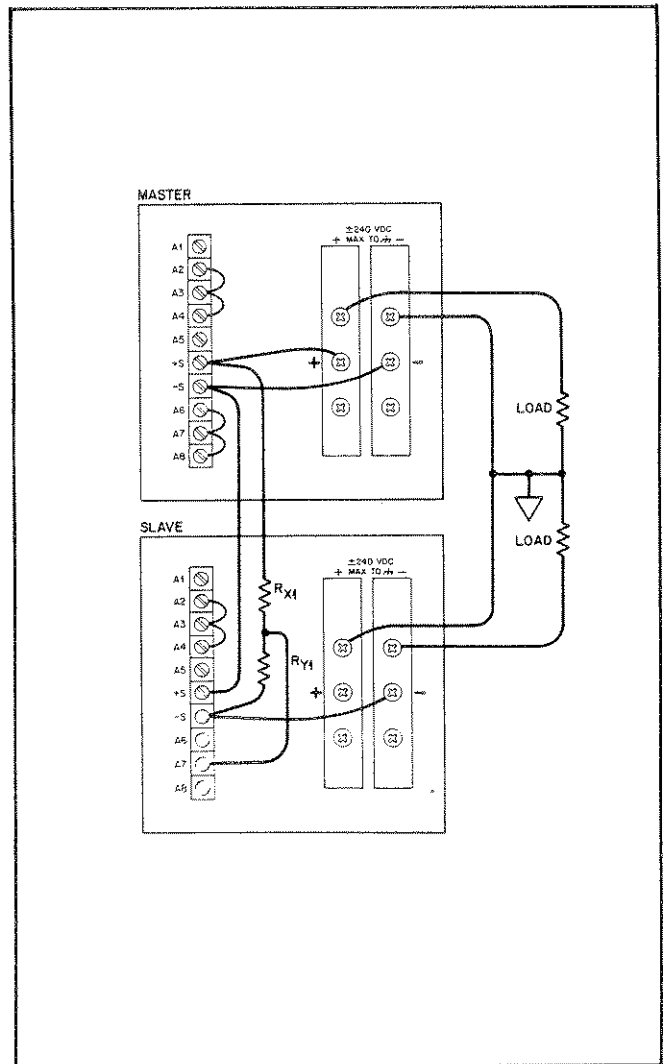

Figure 3-16. Auto-Series Operation, Positive and Negative Outputs

3-73 **Resistor Values.** As shown, each slave has an external voltage divider, R_X and R_Y , that determines its programming voltage. The ratio of R_Y to R_X determines the ratio of a slave's output voltage to the output voltage of its master (the next more-positive supply). To determine the value of R_Y and R_X , first choose the ratio of the slave output voltage to the output voltage of its master (V_M/V_S), select a value for R_Y , and then determine the value for R_X by solving this equation:

$$R_X = \left[12 (R_Y) \left(1 + \frac{V_M}{V_S} \right) \right] - R_Y$$

For example, assume a two-supply combination that is to provide 90 volts, 50 volts from the master and 40 volts from the slave. If we select a value of 1k for R_Y , the equation becomes:

$$R_X = \left[12(1000) \left(1 + \frac{50}{40} \right) \right] - 1000$$

$$R_X = [12,000 (2.25)] - 1000$$

$$R_X = 26,000$$

3-74 Note that the slave output voltage may be lower than, equal to, or higher than the master output voltage.

3-75 Two factors must be considered when selecting the resistance value of R_Y ; the effect on programming specifications, particularly speed, and the power that the resistor will have to dissipate. In the previous example, with a total resistance of 27k across an output of 90 volts, R_X will have to dissipate 290 milliwatts and R_Y will have to dissipate slightly more than 11 milliwatts. Lower resistance values of R_X and R_Y will increase programming speed while increasing the amount of power that R_X and R_Y will have to dissipate.

3-76 To maintain the temperature coefficient and stability specifications of the supplies, R_X and R_Y must be stable, low-noise resistors with temperature coefficients of less than 25 ppm per °C and power ratings of at least 10 times what they will actually dissipate.

3-77 The front-panel VOLTAGE control of the slave can be used in place of R_Y by connecting a strap from A7 of the slave to A8 of the slave. This enables the user to vary the percentage of the total voltage contributed by the slave. For calculation purposes, use a resistance value of 2.7k for the VOLTAGE control when it is set to maximum.

3-78 **Overvoltage Protection in Auto-Series.** Set the OVP trip point in each supply so that it trips at a level higher than the voltage that supply will contribute. If the master supply OVP trips, the master will program the slaves to zero output. If a slave OVP trips, that slave and all slaves between it and the negative end of the series will go to zero output; all units more positive than the tripped slave (which includes the master) will continue to supply their set output voltage. Therefore, the total output voltage of the auto-series combination will be the sum of the outputs from the master plus any slaves between the master and the tripped slave.

3-79 For maximum protection against overvoltage, set each unit's OVP slightly higher (1.5 volts + 1% V_{OUT}) than the voltage it will contribute. For maximum protection against false tripping, set the slave OVPs to maximum and adjust OVP at the master.

3-80 **Auto-Series with Remote Sensing.** To combine auto-series operation with remote sensing, connect the supplies as described above but remove the + S jumper from the master supply and the - S jumper from the most negative supply, and connect the + S and the - S terminals directly to the + and - ends of the load.

3-81 The output voltage and/or current of an auto-series combination can be remotely programmed. Remote programming connections are made to the master supply. The percentage of the total voltage contributed by a slave can also be remotely programmed by connecting a variable resistor to the slave in place of R_Y . Observe all precautions outlined in the remote programming paragraphs. Simultaneous use of remote sensing and remote programming is also possible during auto-series operation.

3-82 Auto-Tracking Operation

3-83 Figure 3-17 shows the interconnections required to operate two or more units in auto-tracking mode. This mode of operation allows multiple supplies that share a common negative (or positive) output bus to power separate loads and have their output voltages simultaneously programmed by the voltage and current controls of the master supply. The output voltage of each slave supply varies in direct proportion to that of the master. The ratio of each slave's output voltage to the master's is established by the ratio of the resistors in the voltage divider connected between + S of the master and - S of the slave.

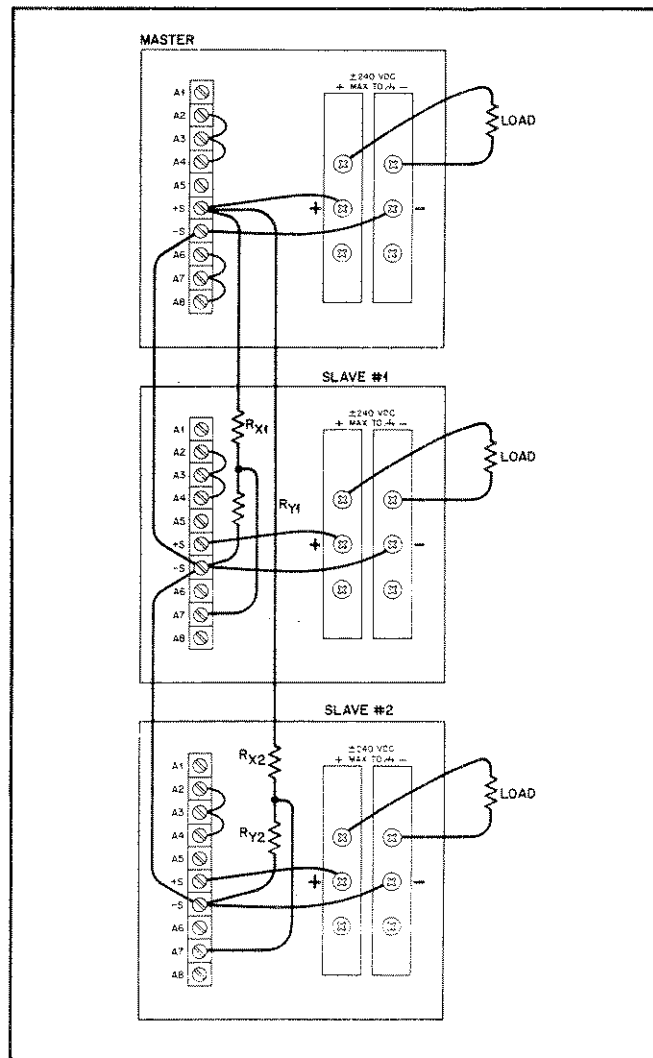

Figure 3-17. Auto-Tracking Operation

3-84 Figure 3-18 shows the interconnections required to provide both positive and negative outputs from an auto-tracking combination. As can be seen, the only difference from standard auto-tracking operation is that the + output terminal of slave #2 instead of the - output terminal is connected to the common bus. There is no limit to the number of supplies that can be operated in either auto-tracking configuration.

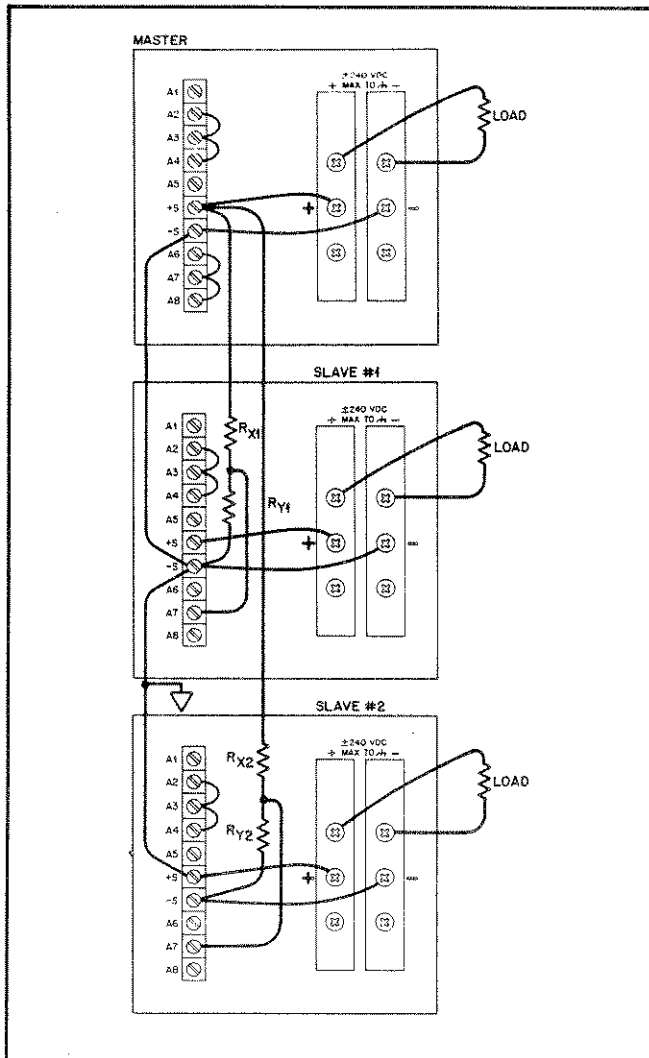

Figure 3-18. Auto-Tracking Operation, Positive and Negative Outputs

3-85 Resistor Values. The method for determining the values of R_X and R_Y in Figure 3-17 is similar to that given in Paragraph 3-73 for auto-series mode. First choose the ratio of the slave output voltage to the master output voltage, select a value for R_Y , and then determine the value for R_X by solving this equation:

$$R_X = R_Y \left[\left(12 \frac{V_M}{V_S} \right) - 1 \right]$$

3-86 For example, assume a two-supply configuration in which the slave output is to vary from 0 to 50 volts while the master output varies from 0 to 30 volts. If we select a value of 1k for R_Y , the equation becomes:

$$R_X = 1000 \left[\left(12 \frac{30}{50} \right) - 1 \right]$$

$$R_X = 1000 [7.2 - 1]$$

$$R_X = 6200$$

3-87 The same factors that govern the choice of R_Y in auto-series mode apply in auto-tracking mode.

3-88 Repeat the process for each slave, with each slave referenced to the same (master) supply (unlike auto-series mode). Note that the slave output voltage may be lower than, equal to, or higher than the master output voltage.

3-89 For auto-tracking operation with both positive and negative outputs, as shown in Figure 3-18, the equation in Paragraph 3-85 is used to determine the values of R_X and R_Y for the slave providing positive outputs, and the equation in Paragraph 3-73 is used to determine the values of R_X and R_Y for the slaves providing negative outputs.

3-90 To maintain the temperature coefficient and stability specifications of the supplies, R_X and R_Y must be stable, low-noise resistors with temperature coefficients of less than 25 ppm per °C and power ratings at least 10 times what they will actually dissipate.

3-91 The front-panel VOLTAGE control of the slave can be used in place of R_Y by connecting a strap from A7 of the slave to A8 of the slave. This enables the user to vary the ratio of the slave output voltage to the master output voltage. For calculation purposes, use a resistance value of 2.7k for the VOLTAGE control when it is set to maximum.

3-92 Setting the Current Controls. The current controls of all supplies in an auto-tracking combination are independently operative and can be used to set current limits for each individual load. If the master supply goes into the constant current mode, the output voltages of the slaves continue to track that of the master. If a slave goes into constant current mode, however, no other supply is affected.

3-93 Overvoltage Protection in Auto-Tracking. Set the OVP of each supply as appropriate for the load connected to that supply. If the master supply OVP trips, the master will program the slaves to zero output. If a slave OVP trips, only that slave and its load will be affected.

3-94 Auto-Tracking with Remote Sensing. To combine auto-tracking operation with remote sensing, connect the supplies as described above but remove the +S and -S jumpers from each supply and connect the +S and -S terminals directly to the + and - ends of its load.

3-95 Auto-Tracking with Remote Programming. The output voltages of an auto-tracking combination can be remotely programmed by programming connections made to the master supply. In addition, the ratio of each slave's output to the master's output can be remotely programmed by connecting a variable resistor to the slave in place of R_Y . The output currents of the individual supplies can also be remotely programmed. Observe all precautions outlined in the remote programming paragraphs. Simultaneous use of remote sensing and remote programming is also possible during auto-tracking operation.

3-96 I-MONITOR OUTPUT SIGNAL

3-97 An amplified and buffered output signal from the current-monitoring resistor is available between terminals A1 and A5 on the rear panel. This signal can be connected to a remote voltmeter to indicate the amount of output current.

The signal varies from 0 to 5 volts to indicate a zero to full scale (50A) current output. The – terminal of the voltmeter should be connected to terminal A5. Output impedance at terminal A1 is 10k; a load of 1 megohm will maintain 2% reading accuracy.

MANUAL CHANGES
 Model 6012A DC Power Supply
 Manual HP P/N 06012-90001

Make all corrections in the manual according to errata below, then check the following table for your power supply serial number and enter any listed changes(s) in the manual.

SERIAL		MAKE
Prefix	Number	CHANGES
All	---	Errata
1946A	00101-00140	1
2047A	00141-00260	1,2
2116A	00261-00300	1-3
2121A	00301-00540	1-5,8*
2136A	00541-00680	1-6,8*
2147A	00681-00770	1-7,8*
2204A	00771-00810	1-8
2207A	00811-00960	1-9,10*
2213A	00961-01110	1-10
2228A	01111-01360	1-11
2241A	01361-01585	1-12
2302A	01586-01935	1-13
2329A	01936-02260	1-14
2402A	02261-02285	1-14
2404A	02286-02335	1-15
2405A	02336-02360	1-16
2406A	02361-02385	1-17
2412A	02386-02485	1-18
2420A	02486-02635	1-19
2426A	02636-02642	1-19
2426A	02642-02891	1-20
2426A	02892-02908	1-21
2426A	02909	1-20
2426A	02910	1-21
2451A	02911-up	1-21

ERRATA:

In paragraph 2-24, step b should also be performed with a full load, as described in step c.

On page B-2, change INPUT POWER specifications to: Two internal switches and two internal jumpers permit operation from 100Vac (-10%, +5%), 48-63 Hz. Maximum input current is 24 A rms. Eliminate PEAK INRUSH CURRENT values for 120, 220, and 240k Vac. (Specifications for 120, 220, and 240 Vac are given in Table 1-1). In paragraph B-53, change HP P/N of R136 to 0698-4486, R151 to 0757-0471. On Figure 7-9, change R19 (between + and - output lines, just to right of own Programmer) to 6 k. In the Overvoltage protection Circuit, the wiper of A5R4 is connected to J2-2.

CHANGE 1:

In the replaceable parts list for A2 Control Board Assembly; add CR31, HP P/N 1901-0033; and R89, 1 M ohm +/-5%, HP P/N 0683-1055; change CR19 to HP P/N 1901-0033. CR31 is mounted next to C31, with its cathode connected to CR19 and its anode connected to R57. R89 is mounted between the cathode end of CR19 and the end of R60 closer to U6. On the schematic, add CR31 and R89 to the output of the CC Circuit as shown below.

The operation of the CC Circuit is essentially the same as described in paragraphs 4-21 through 4-26, except that there is an extra diode drop in the output of the CC Circuit.

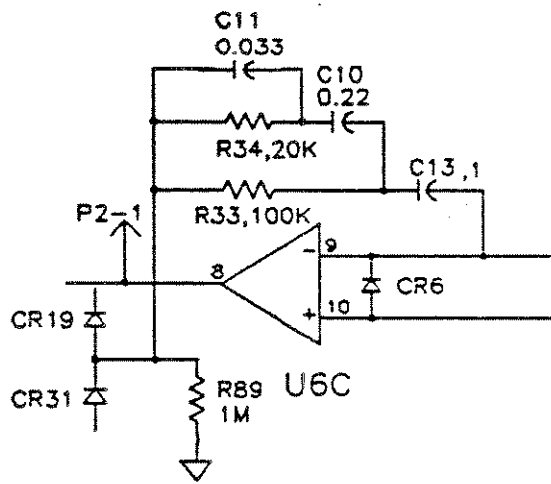

CHANGE 2:

In the replaceable parts list make the following changes: on page 6-3, R20 from HP P/N 06012-80005 to HP P/N 06012-80006; on page 6-5, R27 from HP P/N 0698-6335 (900 ohm) to HP P/N 0698-6341 (750 ohm). On page 6-5, R8 from HP P/N 0757-0413 (392 ohm) to HP P/N 0757-0410 (301 ohm).

CHANGE 3:

In the replaceable parts list, page 6-9, under Chassis Mechanical, add bumper feet HP P/N 04023-0266, qty. 3.

CHANGE 4

In the replaceable parts list, page 6-8, change Fan-tube axial 115 V to HP P/N 3160-0301. (When ordering a new fan the hardware listed below must be ordered). On page 6-9, under Chassis Mechanical, add screw HP P./N 2370-0026, qty. 4 and nut HP P/N 0590-0653, qty. 4.

CHANGE 5:

In the replaceable parts list, page 6-5, change R133 and R134 to 110 k, 1/8 W, 1%, HP P/N 0757-0466. On page 6-7, under FET Assembly, add L2 and L3, ferrite bead, HP P/N 9170-0894, qty. 2.

CHANGE 6:

In the replaceable parts list, page 6-7, under A3 FET Assembly, change Q1,2 to FET-dual TO3 HP P/N 5080-1991.

ERRATA:

On page 1-3, under Programming Response Time, change the first sentence to read: "Maximum time for output voltage to change from 2 V to 60 V...". In Appendix B page B-2, under Programming Response Time, change the first sentence to read: "Maximum time for output voltage to change from 2 V to 50 V or 50 V to 2 V and settle within the 200 mV band...".

CHANGE 7:

On page 6-8, under Main Board Mechanical, change the quantity of contact-terminal, HP P/N 1251-0600, from 4 to 6. Under Front Panel Assembly-Mechanical add: Fan cable assembly, HP P/N 8120-3468, qty 1. This fan cable assembly was soldered directly onto the circuit board, now it is attached by means of two contact terminals. In the replaceable parts list, page 6-9, under Chassis-Mechanical, add cable bushing HP P/N 1251-6532, qty. 1.

ERRATA:

On page 1-2, paragraph 1-18, add the following statement under Front handle kit for 5 1/4 inch high cabinets: "(will be shipped with instrument if ordered as Opton 907)". On page 5-11 Figure 5-11, add the following section to the flow chart where the first decision box appearing below is the same as the one appearing in the manual.

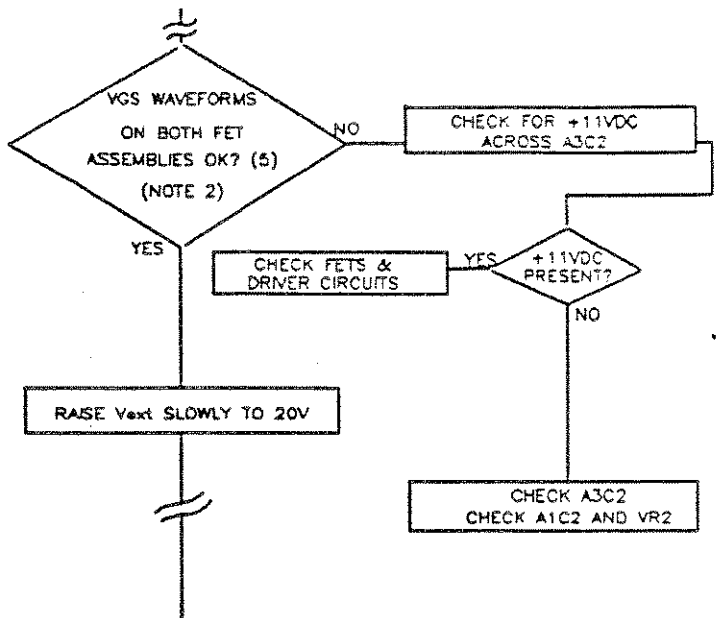

ERRATA:

In Section II (Installation), page 2-2, paragraph 2-18 should read: "Input power is connected to the instrument via the AC Filter Assembly on the rear panel. The power cord must be a three-conductor cord rated for at least 85 degrees C. For 120 V operation each conductor must be AWG #12 (3.31mm²) or larger. For 220 V or 240 V operation, each conductor must be AWG #14 (2.08mm²) or larger. Larger wire sizes may be required to prevent excessive voltage drop in the AC input."

CHANGE 8:

*This change also applies to the following serial numbers:

2121A-00327	2147A-00684
2121A-00334	2147A-00687
-----	-----
2136A-00600	2147A-00688-00692
2136A-00609	2147A-00695
2136A-00612	2147A-00699
2136A-00615-00617	2147A-00700-00703
2136A-00645	2147A-00705
2136A-00563	2147A-00707
2136-00670-00672	2147A-00708
2136A-00676-00679	2147A-00170-00717
-----	-----

In the replaceable parts list, page 6-3, add CR14 HP P/N 1901-0050, qty. 1. On the schematic Figure 7-9, add CR14 across Q2, Base (cathode) to Emitter (anode).

CHANGE 9:

In the replaceable parts list, page 6-4, change C27 to cap 3.3 uF 5% 15V HP P/N 0180-2264.

CHANGE 10:

*This change also applies to the following serial numbers: 2207A-00949, 2207-00950 207A-00952. Change L2 and L3 (previously added in CHANGE 5) to Inductor 0.15 uH, HP P/N 9100-1610, qty. 2. In the replaceable parts list, page 6-7 under FET Assembly, change R9 to res 110 k 1% 1/8 W, HP P/N 0757-0466.

CHANGE 11:

In the replaceable parts list, page 6-3, change A1Q2 to HP P/N 1854-0456, and on page 6-8, under A1 Main Board Mechanical, delete "spacer, plastic (Q2)," HP P/N 1200-0181.

CHANGE 12:

In the replaceable parts list, page 6-7 under A5 Front Panel Assembly add the following note to R4: When replacing R4, check the casing style. If the casing is square, order the R4 HP P/N 2100-3252 listed in the manual. If the casing is round, order HP P/N 2100-2216. Both resistors are the same value but, because of their different casing style they are not interchangeable.

CHANGE 13:

In the replaceable parts list, page 6-8 under Chassis Electrical Parts, change L6 to HP P/N 06012-80099.

ERRATA

The Terminal Block reference printed on the A2 control board is incorrectly labeled TB2 and should be labeled TB1. The manual references the correct label TB1, thus requiring no change to the manual.

CHANGE 14:

In the replaceable parts list page 6-4, under A2 board, add CR40 and CR41, HP P/N 1901-0033, qty 2. On the schematic Figure 7-9 connect CR40 cathode end to TB2A1 and anode end to TB1A5. Connect CR41 cathode end to TB1A5 and anode end to TB1A8.

ERRATA:

In the replaceable parts list, page 6-7, under FET Assembly, change Q1,2 (previously changed in change 6) to HP P/N 1855-0473.

CHANGE 15:

In the replaceable parts list, page 6-3, under A1 Main Board Assembly, change VR2 to zener, 11V, 2%, HP P/N1902-3172, qty 1. Also, make this change to the Schematic Diagram figure 7-9.

CHANGE 16:

In the replaceable parts list for Option #002, page A-15, change U7,8 to HP P/N 1826-0986.

CHANGE 17:

In the replaceable parts list, page 6-8, change Fan-tubeaxial to HP P/N 3160- 0259.

CHANGE 18:

Diodes CR40 and CR41 added in change 14 have been moved from the A2 Terminal Block to the A2 PC Board. They are now located on the A2 PC Board as follows; CR40 is next to R4 and CR41 is next to R18. Make these additions on page 7-4, figure 7-3, Control Board (A2) component location. Electrically CR40 and CR41 are connected as described in CHANGE 14.

In the replaceable parts list, on page 6-4, under A2 Control Board Assembly add, C60, 0.1uF, 50V, HP P/N 0160-4722, TQ 1, On page 6-6 add R180, 1K, 5%, 1/4W, HP P/N 0683-1025, TQ 1, R181, 56.2K, 1%, 1/8W, HP P/N 0757-0459, TQ 1, and R182, 10K, 1%, 1/8W, HP P/N 0757-0442, TQ 2. Make these additions on page 7-4, figure 7-3, Control Board (A2) Component location as follows; R180, R181, R182, and C60 are added between resistors R98 and R92, the finished change should display the components in the following order; R98, R180, R181, R182, C60 and R92. Add R180, R181, R182 and C60 to the Schematic Diagram, Figure 7-9 as shown below. These components are added on the A2 Board in the Dropout Detector/Slow Start Circuit.

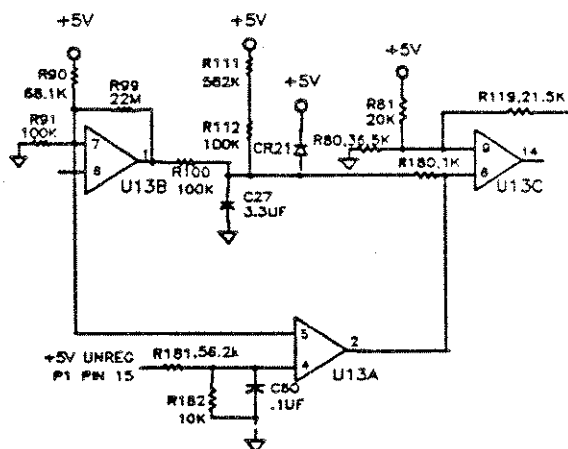

CHANGE 18 (cont.)

On page 6-5 change R81 to 20K, 1%, 1/8W, HP P/N 0757-0449, TQ 1 and change the TQ of R28 to 2. On page 6-6 change R119 to 21.5K, 1%, 1/8W, HP P/N 0757-0199, TQ 1.

CHANGE 19

In the Replacement Parts list, page 6-3, add C29, .047uf, 250Vac, TQ 1, HP P/N 0160-4323. On Figure 7-9 Schematic Diagram, near the LINE SWITCH ASSEMBLY, sketch C29 between points P2 and r2. On page 7-3, Figure 7-2 Main Board (A1) Component Location, capacitor C29 is installed from standoff R1 to standoff R3.

ERRATA:

In the replaceable parts list, page 6-3, change CR3 and CR4 to HP P/N 1901 -1154, qty. 2.

CHANGE 20

In the replaceable parts list, page 6-9, under Chassis-Mechanical change front panel to HP P/N 06012-00016. Change Bracket Meter to HP P/N 06012- 00017, Qty.1. On page 6-7, under Front-Panel Assembly, change meter-volts to HP P/N 1120-1902 and change meter-amps to HP P/N 1120-1901.

ERRATA:

In the replaceable parts list, page 6-9, under Miscellaneous, change jumper, terminal block to HP P/N 0360-2187.

In the replaceable parts list, page 6-8, under FET Assembly, change contact-connector, to HP P/N 1251-7600, qty. 2.

CHANGE 21:

In the replaceable parts list, page 6-9, under Chassis-Mechanical change front panel to HP P/N 06012-00002, TQ 1 and change bracket meter to HP P/N 06012-00012 ,TQ 1. On page 6-7, under Front-Panel Assembly, change meter-volts to HP P/N 1120-1392 TQ 1 and change meter-amps to HP P/N 1120-1393, TQ 1.

1/23/85

SECTION IV PRINCIPLES OF OPERATION

4-1 DIFFERENCE BETWEEN AN AUTORANGING POWER SUPPLY AND A CONVENTIONAL POWER SUPPLY

4-2 The main difference between an autoranging power supply and conventional types of constant voltage/constant current (CV/CC) power supplies can be seen by comparing the output characteristics of each. A conventional CV/CC power supply can provide maximum output power at only one combination of output voltage and current, as shown in Figure 4-1A. The range of a power supply can be extended by designing an instrument with two or more switch-selectable voltage/current ranges within the maximum power output capability, as shown in Figure 4-1B. The 6012A autoranging power supply provides maximum output power over a wide and continuous range of voltage and current combinations, as shown in Figure 4-1C, without the operator having to select the proper output range.

4-3 SIMPLIFIED SCHEMATIC DESCRIPTION

4-4 The basic operating concepts of the 6012A are shown on the simplified schematic, Figure 4-2, and described in the following paragraphs. Detailed descriptions are provided only for those individual circuits and components whose operation may not be obvious to the user. The circuit names and layout of the simplified schematic are the same as used on the complete schematic in Section VII; however, some items, such as the Display Circuits, are left off the simplified schematic for clarity. The heavy lines represent the input rails and output rails. Positive logic conventions are used; signals with a bar are low when true. (E.g., $\overline{\text{ON INHIBIT}}$ goes low to inhibit on pulses, high to enable on pulses.)

4-5 Basic Concept

4-6 The 6012A is a flyback-type switching power supply, so-called from the flyback technique of generating high voltage in television receivers. In the 6012A, energy is stored in the magnetic field surrounding a transformer while current flows in the primary, and this energy is transferred to the secondary circuit when current flow in the primary is turned off. Current flow in the primary is controlled by FET switches, which are turned on and off at a 20kHz rate by a pulse width modulator. Regulation is accomplished by controlling the on time of the FET switches. On pulses are initiated by a clock circuit. Off pulses are initiated when current flow in the primary has stored enough energy for the output circuit, which is determined as follows.

4-7 The output voltage and current are compared to reference voltages set by front-panel controls to produce a control voltage. The control voltage indicates the amount of power required by the output circuit. Current flow in the primary circuit produces a ramp voltage that represents the amount of energy being stored for transfer to the output circuit. An off pulse is generated when the ramp voltage exceeds the control voltage.

4-8 Input AC Circuits

4-9 Primary power is connected through the RFI Filter to the LINE switch and contacts of relay A1K1. When the LINE switch closes, current flows through A1R1 and A1R3 and the Input Bridge/Doubler to charge the Input Filter. A jumper in

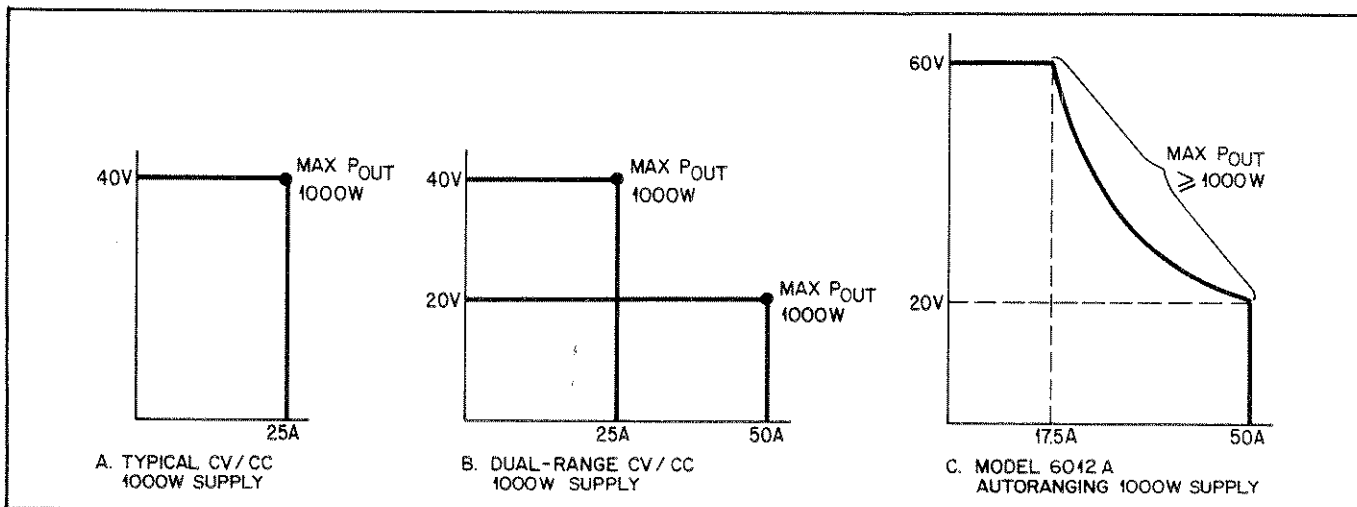

Figure 4-1. Output Characteristics; Typical, Dual-Range, and Autoranging Supplies

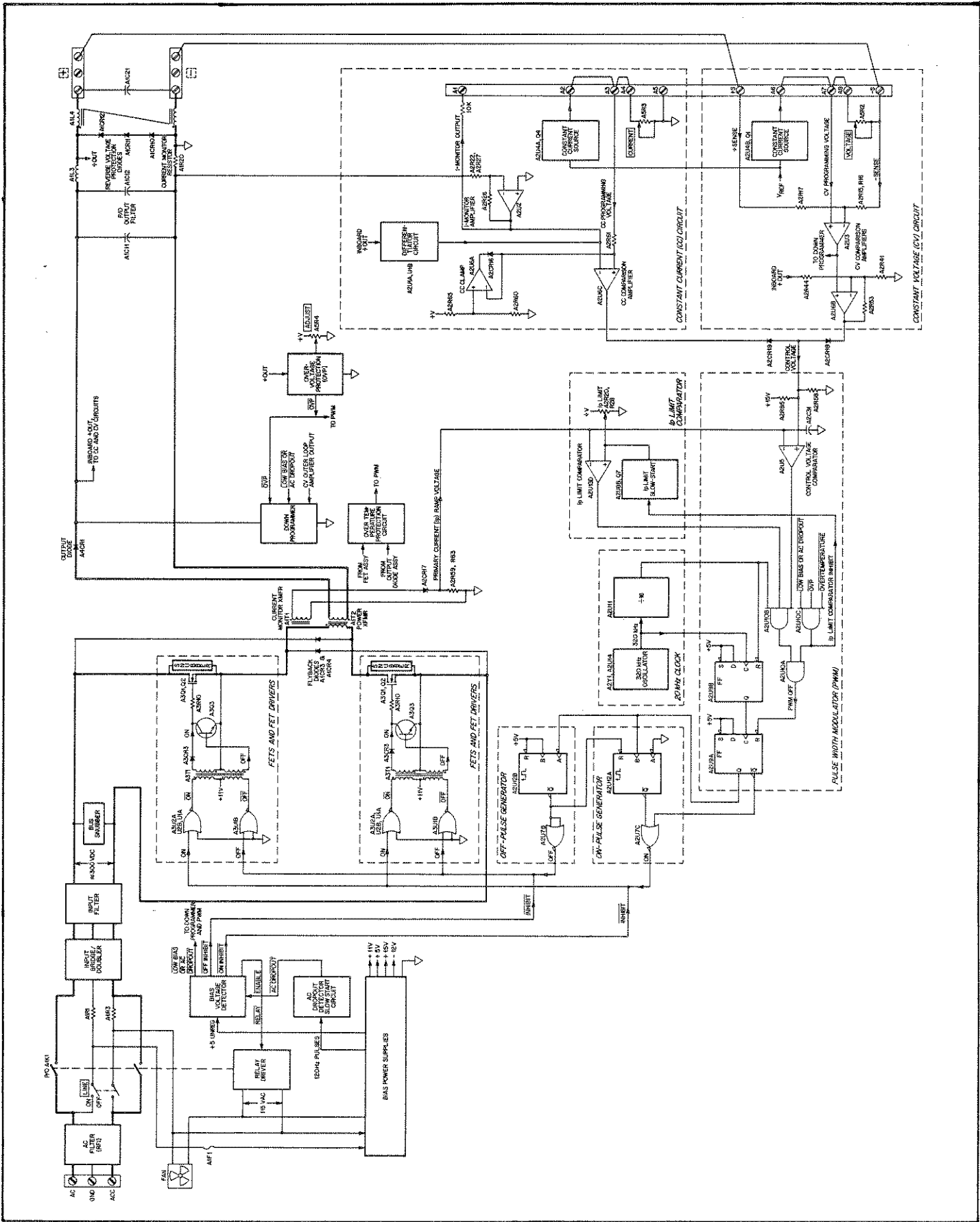

Figure 4-2. Simplified Schematic

the Input Bridge/Doubler circuit, W1, connects the circuit as a voltage doubler for 120V operation, so that for any nominal input voltage the input filter charges to approximately 300Vdc. Resistors A1R1 and A1R3 limit inrush current while the capacitors in the Input Filter charge up after the instrument is turned on. After a one-second delay provided by the AC Dropout Detector/Slow-Start Circuit, relay A1K1 closes and shorts out A1R1 and A1R3.

4-10 Primary power is also connected to the Bias Power Supplies and the Relay Driver. The Bias Power Supplies produce the +5V, +15V, and -12V used throughout the instrument, and the +11V used by the FET drivers. Also provided from the Bias Power Supply circuits are the 120Hz-pulse input to the AC Dropout Detector/Slow-Start Circuit and the +5V unregulated-voltage input to the Bias Voltage Detector. These two circuits operate as described in later paragraphs to produce the relay-enable signal that controls relay A1K1.

4-11 Current flow from the input rails through Power Transformer A1T2 is controlled by a parallel pair of FET switches in each of the two identical FET and FET driver circuits. On and off signals for the FETs are derived from the Pulse Width Modulator (PWM), as will be described shortly. The on pulses are applied through drivers A3U2A, U2B, and U1A and transformer A3T1 to the gates of FETs A3Q1 and Q2. Although the on pulse is less than 2 microseconds duration, the FETs' input capacitance holds the FETs on after the on pulse has disappeared.

4-12 When the FETs are turned on, current flows through the primary of Power Transformer A1T2. (One of the leads for A1T2 serves as the primary for Current-Monitor Transformer A1T1.) Output Diode A4CR1 is reverse biased and blocks current flow through A1T2 secondary. Consequently, energy is stored in the field that builds around the A1T2 transformer windings. The longer that voltage is applied to the primary, the more energy is stored.

4-13 Current flow in the secondary of A1T1 develops the I_p Ramp Voltage across resistors A2R59, R63. The amplitude of this linearly increasing voltage corresponds to the amount of current flow through the A1T2 primary; therefore, it represents the amount of energy being stored in the field around A1T2. It is this I_p Ramp Voltage that is compared to a control voltage to determine when the FETs should be turned off.

4-14 Off pulses for the FETs are applied through driver A3U1B and transformer A3T1 to the base of transistor A3Q3. A3Q3 turns on and shorts the FETs' gates to sources, thereby turning the FETs off. When the FETs turn off, the collapsing magnetic field reverses the polarity across the A1T2 primary, and current flows from A1T2 secondary through Output Diode A4CR1 to charge output capacitors A1C11, A1C12, and A1C21. The level to which the output capacitors are charged corresponds to the length of time that the FETs are on and current flows in A1T2 primary.

4-15 When the FETs turn off, the leakage inductance of A1T2 develops a small amount of reverse current flow in the primary circuit. Flyback Diodes A1CR3 and A1CR4 protect the FETs by conducting this current around the FETs and back to the Input Filter. Voltage spikes are filtered by the Snubber networks.

4-16 It can be seen that the power available in the output circuit corresponds to the duty cycle of the FET switches. The following paragraphs describe the method by which output voltage and current are sensed to control the FET duty cycle.

4-17 Constant Voltage (CV) Circuit

4-18 The Constant Voltage (CV) Circuit compares a percentage of the output voltage to the CV Programming Voltage set by the VOLTAGE control. Any difference is amplified to establish a control voltage, as follows.

4-19 Current from the Constant Current Source flows through VOLTAGE control A5R2 to develop the CV Programming Voltage at terminal A7. The level of this programming voltage is dependent on the setting of A5R2. Amplifier A2U3 compares a fraction of the 6012A output voltage at the + Sense terminal to the programming voltage at A7. The output of A2U3 is applied to a second comparison amplifier, A2U6B. This amplifier compares the output of A2U3 to a fraction of the Inboard + Out, which is the + output voltage sensed at the inboard side of the output filter. Use of two comparison amplifier loops provides increased stability for load variations.

4-20 In normal CV mode, the output of A2U6B varies between ≈ -0.5 volts and $\approx +1.0$ volts. It is at its most negative when the load is drawing little or no power from the instrument. Progressively more-positive voltages from A2U6B correspond to increased power demand by the load. The output from the CV Circuit is applied to diode A2CR18.

4-21 Constant Current (CC) Circuit

4-22 Operation of the Constant Current (CC) Circuit is similar to the CV Circuit. Output current from the 6012A develops a voltage across the Current-Monitor Resistor, A1R20. This voltage is amplified and buffered by the I-Monitor Amplifier, A2U2, to isolate the power supply output from currents in the CC Circuit. Comparison Amplifier A2U6C compares the I-Monitor signal to the CC Programming Voltage. In normal CC mode, the output from the CC Circuit also varies between ≈ -0.5 volts and $\approx +1.0$ volts, and is applied to diode A2CR19.

4-23 Differentiator circuit A2U1A and U1B compensates for highly reactive loads. CC Clamp A2U6A limits the current output from the instrument to no more than 55 amperes.

4-24 Control Voltage

4-25 The outputs of the CV and CC Circuits are applied to diodes that connect to a "wired-OR" junction. Whichever circuit is requesting less power will forward bias its output diode and determine the voltage at the wired-OR junction. As stated earlier, the outputs vary between -0.5 volts and $+1.0$ volts, with the more negative levels representing lower power demands. The wired-OR junction at the anodes of A2CR18 and A2CR19 is biased to $+1.5$ volts. Therefore, whichever circuit, CV or CC, produces the more negative output will cause its output diode to be forward biased and thereby determine the Control Voltage. This Control Voltage is compared to the I_p Ramp Voltage to determine when the FET switches are turned off.

4-26 For example, assume the output from the CV Circuit (A2U6B) is $+0.2$ volts and the output from the CC Circuit (A2U6C) is $+0.9$ volts. A2CR18 will be forward biased and the wired-OR junction will be held at $+0.8$ volts (includes the 0.6 volt drop across A2CR18). A2CR19 will be reverse biased, so the CC Circuit will have no effect.

4-27 Pulse Width Modulator (PWM)

4-28 The FET switches are turned on and off at a 20 kHz rate by signals derived from the Pulse Width Modulator (PWM). On pulses are initiated by the 20 kHz Clock signal. Off pulses are initiated when the I_p Ramp Voltage (which indicates the amount of energy being stored for transfer to the output circuit) exceeds the Control Voltage (which indicates

the amount of power required by the output circuit). Figure 4-3 is a timing diagram showing the relationship of various signals that control the FET switches.

4-29 The more negative level of the 20 kHz A2U11 output resets both flip flops A2U9B and A2U9A, and holds them reset until the A2U11 output goes positive. Then, the next positive edge from the output of the 320 kHz Oscillator triggers A2U9B, triggering A2U9A and one-shot multivibrator A2U12A. The FET switches are turned on, current flows through Power Transformer A1T2, and I_p Ramp Voltage starts to rise. When I_p Ramp Voltage exceeds the Control Voltage, the output of A2U5 changes state and flip flop A2U9A is reset, triggering one-shot multivibrator A2U12B to produce an off pulse.

4-30 PWM Fast Turn Off

4-31 Figure 4-3 shows that there is a delay between the time when the Control Voltage is exceeded at A2U5 and the time when the FETs turn off. This delay consists of the comparator switching time, gate delays, transformer delay, and FET turn-off time, and it results in a certain amount of power being transferred to the output after the desired off time. If the Control Voltage is at a very low level (unit supplying little or no output power), this power may exceed the amount required by the load. To offset this, the PWM is designed to reduce the minimum on-time of the FETs if necessary to reduce the power transferred to the output circuit. When the 20 kHz Clock goes high (allowing the PWM to be triggered by the next 320 kHz signal), A2C31 charges rapidly and exponentially

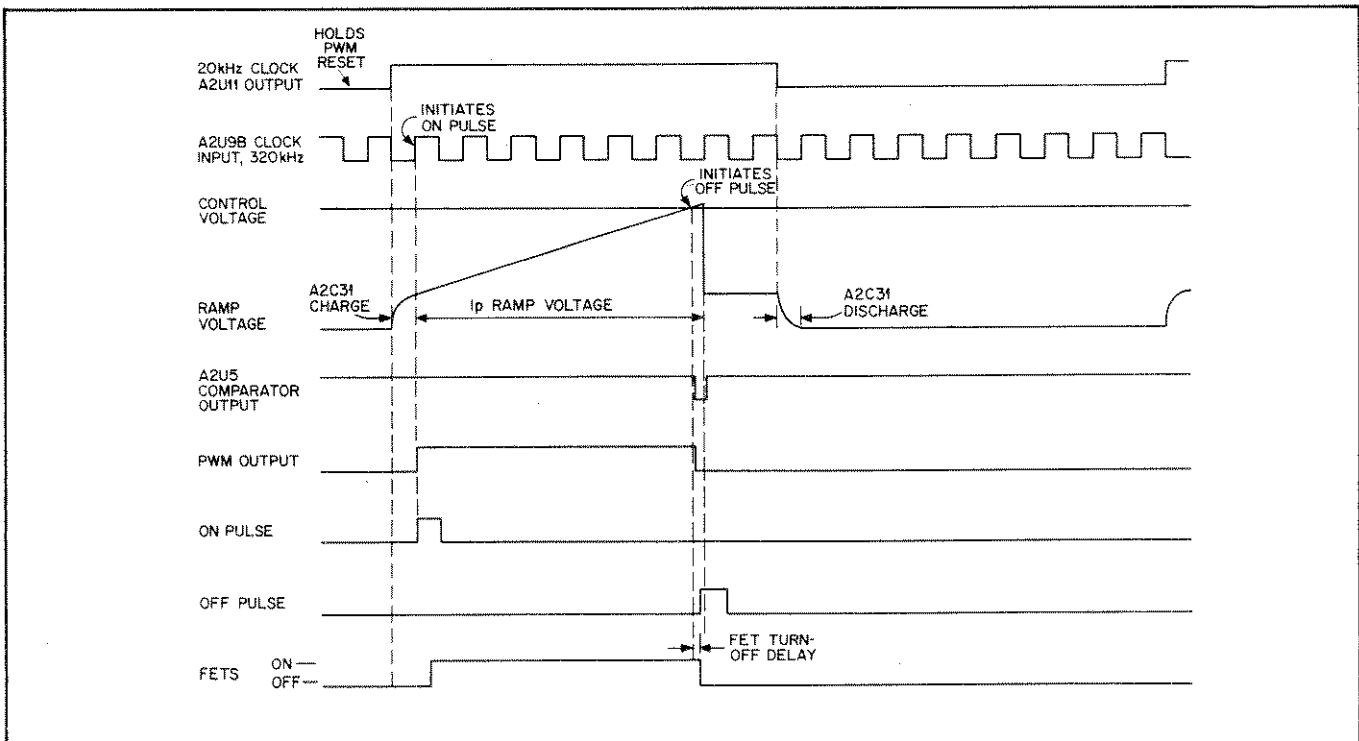

Figure 4-3. FET Control Signals Timing Diagram

to a low level. If this auxiliary ramp level exceeds the Control Voltage, the PWM initiates an off pulse, turning off the FETs immediately after they turn on.

4-32 Primary Current (I_p) Limit

4-33 I_p Ramp Voltage is also compared to a preset I_p Limit at comparison amplifier A2U13D. I_p Limit is a factory-set adjustment that limits the total power output of the instrument. Ordinarily, the PWM initiates an off pulse when I_p Ramp Voltage exceeds the Control Voltage at A2U5, and I_p Ramp never reaches I_p Limit at A2U13D. However, if the Control Voltage is excessively high (both VOLTAGE and CURRENT controls set to relatively high values), I_p Ramp will exceed I_p Limit. The output of A2U13D changes state, initiating an off pulse.

4-34 As an additional protection feature, if nothing else resets flip flop A2U9A (such as the control circuit, overtemperature, low bias or ac dropout, or overvoltage), it will be reset by the next negative level from A2U11, triggering A2U12B to generate an off pulse. Therefore, maximum duty cycle of the FETs is always less than 50%.

4-35 The I_p Limit Comparator also includes a slow-start circuit, which limits the output power the unit can provide until after the A1K1 relay contacts close completely.

4-36 Down Programmer

4-37 This circuit allows the output voltage to be lowered rapidly when required. In order to lower the output voltage it is necessary to discharge the output filter capacitors (typically, through the load). In situations that require the output voltage to drop more rapidly than can be accomplished through the load, the Down Programmer pulls the output line to a low level and discharges the capacitors. This action can be triggered by any of three conditions: The CV Circuit programs a much lower output voltage, an overvoltage is detected on the output, or low bias or ac dropout is detected (including ac turnoff).

4-38 A long-carryover bias supply associated with the Down Programmer stores enough energy to operate the Down Programmer after loss of primary power. This ensures that the Down Programmer will be able to discharge the output circuit completely when primary power is turned off.

4-39 Overvoltage Protection Circuit (OVP)

4-40 The Overvoltage Protection Circuit monitors the output voltage across the + output line and circuit common (- output line). If the output voltage exceeds a preset limit, set by the front-panel OVP ADJUST potentiometer, the Overvoltage Protection Circuit inhibits the PWM, triggers the Down Programmer, and latches itself until the instrument is turned off.

4-41 The Overvoltage Protection Circuit operates from the long-carryover bias supply associated with the Down Programmer. By ensuring that the reference voltage remains high until after the + output reaches zero volts when the instrument is turned off, this feature prevents the Overvoltage Protection Circuit from latching if the unit is turned back on again immediately after turn-off.

4-42 AC Dropout Detector/Slow-Start Circuit

4-43 This circuit contains two ramp circuits. The slow-start ramp holds the output of the AC Dropout Detector/Slow-Start Circuit, AC DROPOUT, low for approximately one second after the instrument is turned on. The AC DROPOUT signal operates through the Bias Voltage Detector to inhibit the power supply output. This one-second delay allows the Input Filter capacitors to charge slowly through A1R1 and A1R3.

4-44 The dropout detector ramp operates to shut down the instrument when primary power is turned off or lost. This ramp circuit is ordinarily reset by the 120 Hz pulses in the unregulated +5 V. If the ramp is not reset within approximately 20 milliseconds of the previous reset, the output of the AC Dropout Detector goes low (AC DROPOUT). AC DROPOUT inhibits the power supply output, as described in the following paragraphs.

4-45 Bias Voltage Detector

4-46 The Bias Voltage Detector inhibits operation of the power circuits if the bias voltage drops below a certain level. This is the level at which sufficient voltage is available to operate the control circuits reliably.

4-47 When the instrument is turned on, the outputs of the Bias Power Supplies begin to rise from zero volts. When the output of the +5V regulated supply reaches approximately 1 volt, transistors in the Bias Voltage Detector turn on and perform the following functions: inhibit the On pulse, Off pulse, and PWM; trigger the Down Programmer; and inhibit the Relay Enable signal. When the +5V unregulated supply reaches approximately 7 volts, the OFF pulse is enabled. When the +5V unregulated supply reaches approximately 9 volts, the On pulse and PWM are enabled, the Down Programmer trigger is removed, and the Relay Enable signal is generated. (This assumes that the AC DROPOUT signal from the AC Dropout Detector/Slow-Start Circuit is not present. AC DROPOUT operates through the Bias Voltage Detector to inhibit the power circuits. Upon turn-on, the one-second delay provided by AC DROPOUT ordinarily exceeds the time required for the bias voltage to reach the proper level.)

4-48 The Bias Voltage Detector also inhibits the power circuits in "brownout" conditions if the ac line voltage falls below approximately 70% of nominal.

SECTION V MAINTENANCE

5-1 INTRODUCTION

5-2 Upon receipt of the power supply, the performance test (Paragraph 5-5) can be made. This test is suitable for incoming inspection. If a fault is detected in the power supply while making the performance test or during normal operation, proceed to the troubleshooting procedures. After troubleshooting and repair (Paragraph 5-52), perform any necessary adjustments and calibration (Paragraph 5-86).

Before returning the power supply to normal operation, repeat the applicable portions of the performance test to ensure that the fault has been properly corrected and that no other faults exist.

5-3 TEST EQUIPMENT REQUIRED

5-4 Table 5-1 lists the test equipment required to perform the various procedures described in this section.

Table 5-1. Test Equipment Required

TYPE	REQUIRED CHARACTERISTICS	USE	RECOMMENDED MODEL
Oscilloscope	Sensitivity: 1 mV Bandwidth: 20 MHz	Troubleshooting; measure ripple, noise spikes, and load transient response	HP 1740A
Digital Multimeter	Sensitivity: 1 μ V Input Impedance: 10 M Ω (minimum) Accuracy: 0.02% 6 1/2 digit	Measure ac and dc voltages, troubleshooting, and calibration	HP 3455A
Electronic Load	Voltage Range: 60V Current Range: 50A Power Range: 1200W Open and short circuit switches Variable at 30 Hz rate	Power supply load	Transistor Devices Model DLP 130-50-2500
Variable Voltage Autotransformer	Voltage Range: see Paragraph 2-15 4 kVA (minimum)	Vary ac input for line regulation measurement, troubleshooting	
RMS Voltmeter	True RMS Reading Bandwidth: 10 MHz Sensitivity: 1 mV	Measure ripple	HP 3400A
DC Power Supply	Voltage Range: 0 to 20V Current Range: 0 to 6A	Troubleshooting, slow-start procedure	HP 6024A
Current-Measuring Transformer	Able to pass 50 A dc without saturating Bandwidth: 20 Hz to 20 MHz Output voltage of at least 1 mV for 1 mA input	Constant Current PARD test	Tektronix Model P6303 Probe/AM503 Amplifier (must be used with TM500-series power module)
Current-Monitoring Resistor	Value: 50 mV @ 50A (1 m Ω) Accuracy: 1% or better	Measure output current, calibration	Weston Instrument Shunt Model 9992, Catalog #41218, 50 mV @50A
Isolation Transformer	4 kVA (minimum)	Troubleshooting	
Terminating Resistors	Value: 50 Ω \pm 5%, Non-inductive (four required)	Noise spike measurement	---
Blocking Capacitors	Value: 0.01 μ F, 100 Vdc, (two required)	Noise spike measurement	---

5-5 PERFORMANCE TEST

5-6 The following test can be used as an incoming inspection check, and appropriate portions of the test can be repeated to check the operation of the instrument after repairs. The tests are performed using the specified nominal input voltage for the unit. If the correct result is not obtained for a particular check, proceed to troubleshooting (Paragraph 5-52).

5-7 Measurement Techniques

5-8 All specifications should be measured at the power supply terminals. Also, all tests are performed with the supply strapped for local programming and sensing, as shown in Figure 3-3. The wires used to connect the load to the supply should be heavy enough to ensure that they will drop less than 0.5V. If the supply is equipped with System Interface Option 002, remove the Interface Option cable from the rear-panel connector and check the power supply first. Then proceed to the checkout procedure in Appendix A to test the Option 002 components.

5-9 **Select A Load.** Specifications are checked with varying amounts of load resistance connected across the supply. For most of the constant-voltage tests, the value of load resistance must be approximately 0.4Ω to permit operation of the supply at 20V and its maximum-output-power-rating current of 50A. For the constant-current tests, the load resistance must be approximately 3.4Ω to permit operation at 17.5A and its maximum-output-power-rating voltage of 60V. The power rating of the load must be at least equal to the maximum output power of the supply: 1200 watts.

5-10 For load regulation and load transient response tests, load resistance must be switched between two values. An electronic load, such as listed in Table 5-1, eliminates the need for connecting many resistors or rheostats in parallel to provide adequate power capability, is considerably more stable than carbon pile devices, and permits varying the load with an external modulating signal.

5-11 **Connecting a Current-Monitoring Resistor.** To allow precise measurement of output current, a current-monitoring resistor, such as the shunt listed in Table 5-1, is inserted between the output of the power supply and the load. This resistor must be connected as a four-terminal device in the same manner as a meter shunt would be (see Figure 5-1). The load current is fed to the extremes of the wire leading to the resistor, while the monitoring terminals are located as close as possible to the resistance element itself. A current-monitoring resistor should have low noise, a low temperature coefficient (less than $30\text{ppm}/^\circ\text{C}$), and should be used at no more than 5% of its rated power so that its temperature rise will be minimized.

5-12 Constant Voltage Tests

5-13 Connect all of the measuring devices used in the constant-voltage performance tests directly to the power sup-

ply sensing terminals (+S, -S). For best accuracy, the sensing terminals must be used rather than the output terminals, since the measuring instruments must be connected to the same pair of terminals to which the feedback amplifier within the power supply is connected. This is particularly important when measuring the regulation of the power supply. A measurement made across the load includes the impedance of the leads to the load, and such lead lengths can easily have an impedance several orders of magnitude greater than the supply impedance (typically < 1 milliohm at dc), thus invalidating the measurement.

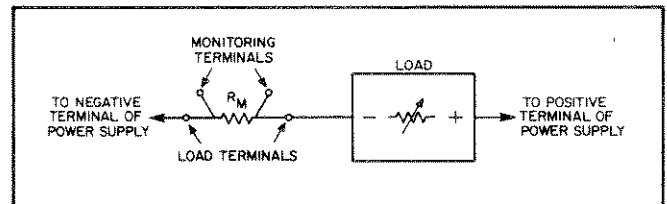

Figure 5-1. Current-Monitoring Resistor Connections

5-14 To avoid mutual coupling effects, connect each monitoring device to the sensing terminals by a separate pair of leads. Use coaxial cable or shielded two-wire cables to avoid pickup on the measuring leads. Connect the load across the output terminals as close to the supply as possible. When measuring the constant-voltage performance specifications, the CURRENT control should be set at least 2% above the output current the load will draw, since the onset of constant-current operation could cause a drop in output voltage, increased ripple and other performance changes not properly ascribed to the constant-voltage operation of the supply.

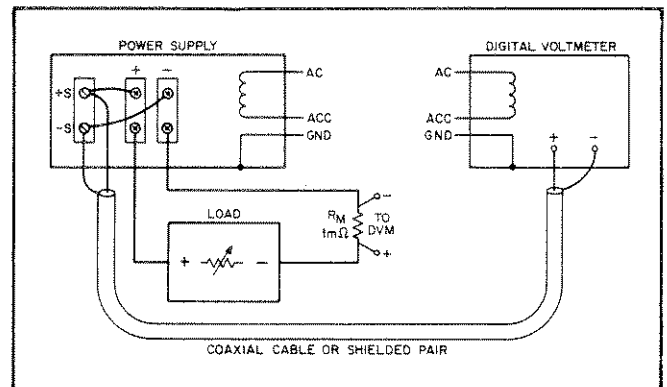

Figure 5-2. Basic Test Setup

5-15 **Rated Voltage and Voltmeter Accuracy.** To check that the supply will furnish its rated output voltage, proceed as follows:

- Connect test setup shown in Figure 5-2. Operate the load in constant resistance mode (Amps/Volt) with resistance initially set to maximum.
- Turn both CURRENT control and OVP adjust fully clockwise.
- Turn on supply and adjust VOLTAGE control until digital

voltmeter (DVM) indicates exactly 60V (maximum rated output voltage).

d. Front-panel voltmeter should indicate $60V \pm 3\%$.

e. Disconnect DVM from power supply sense terminals and connect DVM across current-monitoring resistor (R_M).

f. Reduce resistance of load until DVM reads 17.5 mV, indicating that current output is exactly 17.5A (maximum rated power output). Ensure that power supply remains in constant-voltage mode by checking CV light.

g. Disconnect DVM from R_M and reconnect DVM to power supply sense terminals.

h. DVM and front-panel voltmeter should both indicate 60V.

5-16 Load Effect (Load Regulation).

Definition: The change in the static value of dc output voltage (ΔE_{OUT}) resulting from a change in load resistance from open circuit to a value which yields maximum rated output current, or from the latter value to open circuit.

5-17 To check the constant-voltage load effect, proceed as follows:

a. Connect test setup shown in Figure 5-2.

b. Turn CURRENT control fully clockwise.

c. Turn on supply and adjust VOLTAGE control until DVM indicates 20V.

d. Disconnect DVM from power supply sense terminals and connect DVM across R_M .

e. Adjust resistance of load until DVM reads 50 mV, indicating that current output is exactly 50A (maximum rated output current). Ensure that power supply remains in constant-voltage mode by checking CV light.

f. Disconnect DVM from R_M and reconnect DVM to power supply sense terminals.

g. Open dc circuit breakers on load to disconnect load.

h. Record voltage indicated on DVM.

i. Close dc circuit breakers on load to reconnect load.

j. Wait a few seconds only to allow DVM to settle. Reading on DVM should not differ from reading of step h by more than 7 mV.

5-18 Source Effect (Line Regulation).

Definition: The change in the static value of dc output voltage (ΔE_{OUT}) resulting from a change in ac input voltage over the specified range from low line to high line, or from high line to low line.

5-19 To check the source effect, proceed as follows:

a. Connect test setup shown in Figure 5-2.

b. Connect variable autotransformer between input power source and power supply ac power input.

c. Adjust autotransformer for low line voltage (Paragraph 2-15).

d. Turn CURRENT control fully clockwise.

e. Turn on power supply and adjust VOLTAGE control until DVM indicates exactly 60V.

f. Disconnect DVM from power supply sense terminals and connect DVM across R_M .

g. Adjust resistance of load until DVM reads 4 mV, indicating that current output is exactly 4 A. Ensure that power supply remains in constant-voltage mode by checking CV light.

h. Disconnect DVM from R_M and reconnect DVM to power supply sense terminals.

i. Record voltage indicated on DVM.

j. Adjust autotransformer for high line voltage.

k. Reading on DVM should not differ from reading of step i by more than 9 mV.

5-20 PARD (Ripple and Noise).

Definition: The residual ac voltage superimposed on the dc output of a regulated power supply. Ripple and noise measurements may be made at any input ac line voltage combined with any dc output voltage and current within the supply's rating.

5-21 The amount of ripple and noise present on the power supply output is measured either in terms of its rms or (preferably) peak-to-peak value. The peak-to-peak measurement is particularly important for applications where noise spikes could be detrimental to sensitive loads such as logic circuitry. The rms measurement is not an ideal representation of the noise, because fairly high output noise spikes of short duration can be present in the ripple without appreciably increasing the rms value.

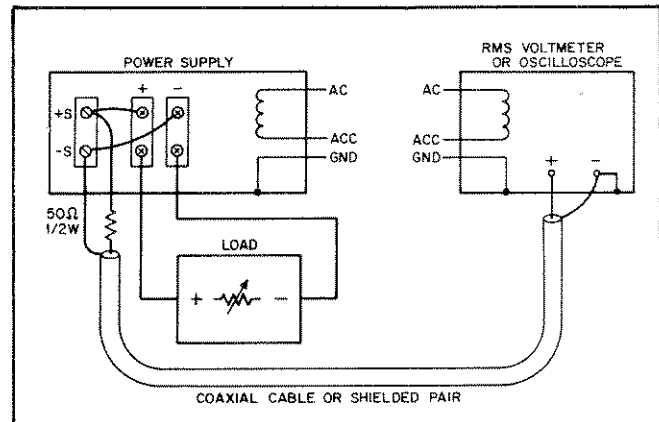

Figure 5-3. Constant-Voltage Ripple Test Setup.

5-22 Ripple Measurement Techniques. Figure 5-3 shows the method for measuring ripple using a single-ended true-reading RMS voltmeter or oscilloscope. The power supply output terminals should not be connected to ground at the power supply terminal strip to prevent current from flowing through a ground loop and adding to the measured signal. Also, to ensure that no potential difference exists between the supply and the RMS voltmeter, it is recommended that they both be plugged into the same ac power bus. If the same bus cannot be used, both ac grounds must be at earth ground potential.

5-23 To minimize pickup, a coaxial cable or shielded two-wire cable should be used to connect the sensing terminals of the power supply to the input of the RMS voltmeter. To verify that the RMS voltmeter is not measuring ripple that is induced in the leads or picked up from ground, turn both the VOLTAGE and CURRENT controls fully counterclockwise and short the voltmeter + lead to the voltmeter - lead at the power supply output terminals. If the test setup is properly configured, the noise value obtained when the leads are shorted should not be significant compared to the measured ripple value.

5-24 **Ripple Measurement Procedure.** To check the ripple output, proceed as follows:

- Connect test setup shown in Figure 5-3.
- Turn CURRENT control fully clockwise.
- Turn on power supply and adjust VOLTAGE control and load so that front-panel meters indicate 40V and 30A.
- Ripple should be less than 5 mV.

5-25 **Noise Spike measurement Techniques.** An instrument of sufficient bandwidth must be used when making a high-frequency spike measurement. Measuring noise with an instrument that has insufficient bandwidth may conceal high-frequency spikes that could be detrimental to the load. The oscilloscope listed in Table 5-1 should be operated with the bandwidth limited to 20 MHz. A modest increase in noise spike amplitude may be observed above 20 MHz.

5-26 A single-ended measurement (replacing RMS voltmeter in Figure 5-3 with an oscilloscope) is usually not adequate for measuring spikes; a differential oscilloscope is necessary. Because of its common-mode rejection, a differential oscilloscope displays only the difference between its two vertical input terminals, thus ignoring the effects of any common-mode signal produced by the difference in the ac potential between the power supply case and the oscilloscope case. Before using a differential-input oscilloscope, however, it is imperative that the common-mode-rejection capability of the oscilloscope be verified. Turn both the VOLTAGE and CURRENT controls fully counterclockwise, short together the two input leads at the power supply, and observe the trace on the CRT. If the trace is a straight line, then the oscilloscope is properly ignoring any common-mode noise present. If the trace is not a straight line, then the oscilloscope is not rejecting the ground signal and must be realigned in accordance with the manufacturer's instructions so that proper common-mode rejection is attained.

5-27 Figure 5-4 shows the test setup used to measure noise spikes. Two coaxial cables must be used. Impedance-matching resistors must be included to eliminate standing waves and cable ringing, and capacitors must be connected to block dc. The length of the test leads outside the coaxial cable should be kept as short as possible. The blocking capacitor and impedance-matching resistor should be connected directly from the inner conductor of the cable to the power supply sensing terminal. Notice that the shields of the two coaxial cables are not connected to the power supply.

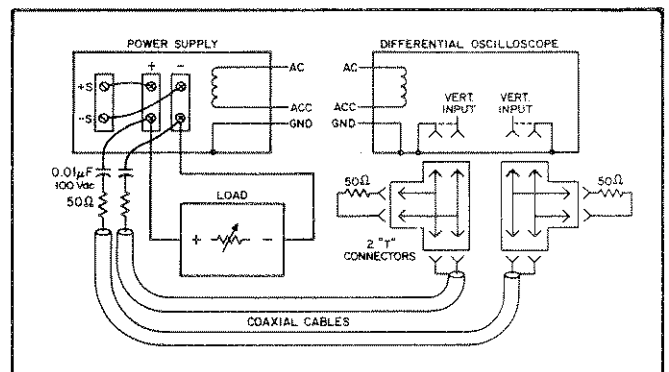

Figure 5-4. Constant Voltage Noise Spike Measurement Test Setup

5-28 **Noise Spike Measurement Procedure.** To check the noise spikes, proceed as follows:

- Connect test setup shown in Figure 5-4.
- Turn CURRENT control fully clockwise.
- Turn on power supply and adjust VOLTAGE control and load so that the front-panel meters indicate 20 V and 50 A.
- Because the impedance-matching resistors constitute a 2-to-1 attenuator, the noise spikes observed on the oscilloscope should be less than 25 mV p-p (instead of 50 mV p-p).

5-29 The circuit of Figure 5-4 can also be used for the display of low-frequency ripple. Simply remove the four terminating resistors and the blocking capacitors.

5-30 **Load Transient Recovery Time.**

Definition: The time "X" for output voltage recovery to within "Y" millivolts of the nominal output voltage following a "Z" amp step change in load current, where "Y" is specified as 100mV and "Z" is the specified load current change of 10% of maximum current rating.

5-31 **Measurement Techniques.** The load must be switched between two resistance values such that the load current varies 10% of the maximum current rating at any output voltage. For example, if the test is done at 40V output, the maximum current available is 30A. Therefore, the current should vary by 3A (10%). A load increase of 0.149 Ω, from 1.333 Ω to 1.482 Ω, will decrease output current from 30 A to 27 A.

5-32 The load change need not be at the maximum current available, as in the previous example, but it should cause a current change of 10% of the maximum current available. Therefore, at the same 40V output, the load would have to decrease 0.218 Ω, from 1.818 Ω to 1.600 Ω, to increase output current by 3A from 22A to 25A. The maximum current available is different at different output voltages, therefore the 10% value is different for each output voltage. The test may be run at whichever output voltage/current combination(s) is/are of most interest. In all cases, however, the load must be selected such that the output current is equal to or greater than 5A both before and after the load change.

5-33 The electronic load listed in Table 5-1 has provisions for externally modulating the load. Use of a 30 Hz square wave modulating signal provides a repetitive display that is easy to observe. Follow the manufacturer's instructions for operating the electronic load to switch the load current by 10% of the power supply's maximum output current capability at the selected output voltage (e.g.: between 90% and 100%, between 35% and 45%, etc).

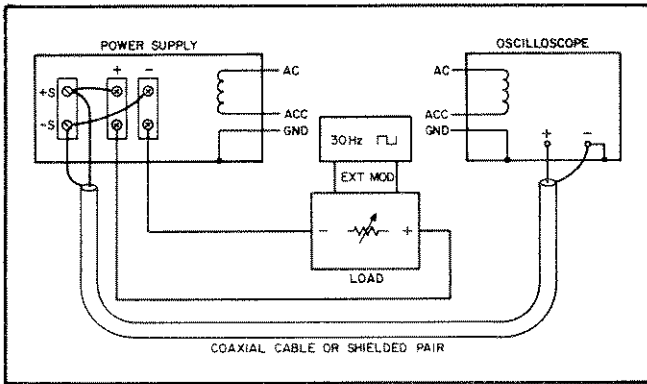

Figure 5-5. Load Transient Recovery Time Test Setup

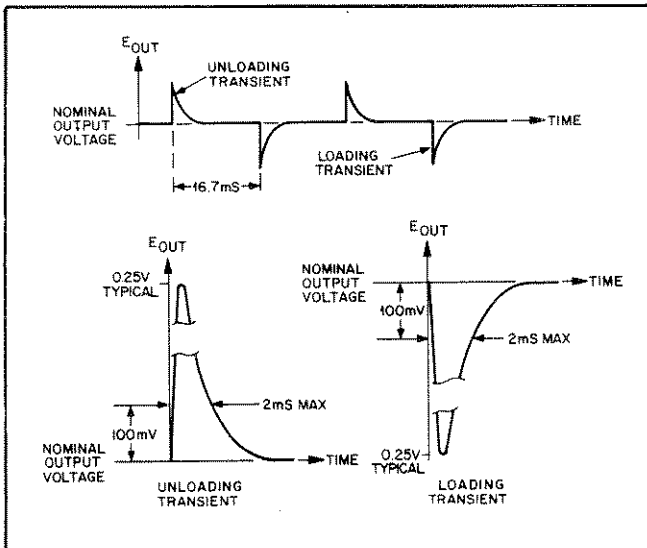

Figure 5-6. Load Transient Recovery Waveforms

5-34 **Measurement Procedure.** To check load transient recovery time, proceed as follows:

- Connect the test setup shown in Figure 5-5.
- Set electronic load for external modulation, and adjust load for maximum current to be used in test.
- Adjust square wave signal source for 30 Hz modulating signal. Signal levels should be chosen in accordance with load manufacturer's requirements for varying load current by the desired amount.
- Set oscilloscope for internal sync and lock on either positive or negative load transient spike.
- Set vertical input of oscilloscope for ac coupling so that small dc level changes will not cause display to shift.

- Adjust oscilloscope to display transients as in Figure 5-6.
- Recovery of power supply output voltage to within 100 mV of nominal output voltage should be within two milliseconds.

5-35 Temperature coefficient.

Definition: The change in output voltage per degree Celsius change in ambient temperature measured while ac line voltage, output voltage setting, and load resistance are all held constant.

5-36 The temperature coefficient of a power supply is measured by placing the unit in an oven and varying the temperature over any span within the power supply's rating. The power supply temperature must be allowed to stabilize for a sufficient time at each measurement temperature.

5-37 The temperature coefficient given in the specification table is the maximum temperature-dependent output voltage change which will result over any one-degree interval. The digital voltmeter used to measure the supply's output voltage change should be placed outside the oven and should have a long-term stability adequate to insure that its drift will not affect the overall measurement accuracy.

5-38 To check the temperature coefficient, proceed as follows:

- Connect load and digital voltmeter as illustrated in Figure 5-2.
- Turn CURRENT control fully clockwise.
- Turn on supply and adjust VOLTAGE control until digital voltmeter (DVM) indicates exactly 60V (maximum rated output voltage).
- Disconnect DVM from power supply sense terminals and connect DVM across current-monitoring resistor (R_M).
- Reduce resistance of load until DVM reads 17.5 mV, indicating that current output is exactly 17.5A (maximum rated power output). Ensure that power supply remains in constant-voltage mode by checking CV light.
- Disconnect DVM from R_M and reconnect DVM to power supply sense terminals.
- Place power supply in temperature-controlled oven (DVM remains outside oven). Set temperature to 30°C and allow 30 minutes warm-up.
- Record DVM reading.
- Raise temperature to 40°C and allow 30 minutes warm-up.
- Observe DVM reading. Difference in voltage reading between steps h and j should be less than 80 mVdc.

5-39 Drift (Stability).

Definition: The change in output voltage for the first eight hours following a 30-minute warm-up period. During the interval of measurement, input line voltage, load resistance, and ambient temperature are all held constant.

5-40 This measurement is made by monitoring the output of the power supply on a digital voltmeter over the stated measurement interval. A strip chart recorder can be used to provide a permanent record. Place a thermometer near the

supply to verify that the ambient temperature remains constant during the period of measurement. The supply should be located away from any source of stray air current. If possible, place the supply in an oven and hold it at a constant temperature. Take care that the measuring instrument has an eight-hour stability at least an order of magnitude better than the stability specification of the power supply being tested. Typically, a supply will drift less over the eight-hour measurement interval than during the half-hour warm-up period.

5-41 To check the output stability, proceed as follows:

- a. Connect load and digital voltmeter (DVM) as illustrated in Figure 5-2.
- b. Turn CURRENT control fully clockwise.
- c. Turn on supply and adjust VOLTAGE control until DVM indicates exactly 60V (maximum rated output voltage).
- d. Disconnect DVM from power supply sense terminals and connect DVM across current-monitoring resistor (R_M).
- e. Reduce resistance of load until DVM reads 17.5 mV, indicating that current output is exactly 17.5A (maximum rated power output). Ensure that power supply remains in constant-voltage mode by checking CV light.
- f. Disconnect DVM from R_M and reconnect DVM to power supply sense terminals.
- g. Allow 30 minutes warm-up, then record DVM reading.
- h. After eight hours, DVM reading should not differ from reading of step g by more than 23 mVdc.

5-42 Constant-Current Tests

5-43 The instruments, methods, and precautions for the proper measurement of constant-current power supply characteristics are for the most part identical to those already described for the measurement of constant-voltage characteristics. The main difference is that the power supply performance will be checked between short circuit and full load rather than open circuit and full load.

5-44 **Current Output and Ammeter Accuracy.** To check that the supply will furnish its rated output current, proceed as follows:

- a. Connect test setup shown in Figure 5-2. Operate the load in constant resistance mode (Amps/Volt) with resistance initially set to minimum.
- b. Turn VOLTAGE control fully clockwise.
- c. Turn on supply and adjust CURRENT control until DVM reads 50 mV, indicating that current output is exactly 50A (maximum rated output current).
- d. Front-panel ammeter should indicate $50A \pm 3\%$.
- e. Disconnect DVM from R_M and connect DVM to power supply sense terminals.
- f. Increase resistance of load until DVM reads exactly 20V (maximum rated power output). Ensure that power supply remains in constant-current mode by checking CC light.
- g. Disconnect DVM from power supply sense terminals and reconnect DVM across R_M .
- h. DVM should indicate 50 mV, front-panel ammeter should indicate $50A \pm 3\%$.

5-45 Load Effect (Load Regulation).

Definition: The change in the static value of the dc output current (ΔI_{OUT}) resulting from a change in load resistance from short circuit to a value which yields maximum rated output voltage, or from the latter value to short circuit.

5-46 To check the constant-current load effect, proceed as follows:

- a. Connect test setup shown in Figure 5-2.
- b. Turn VOLTAGE control fully clockwise.
- c. Turn on supply and adjust CURRENT control until DVM reads 50 mV, indicating that current output is exactly 50A.
- d. Disconnect DVM from R_M and connect DVM to power supply sense terminals.
- e. Adjust resistance of load until DVM indicates 20V. Ensure that power supply remains in constant-current mode by checking CC light.
- f. Disconnect DVM from power supply sense terminals and reconnect DVM to R_M .
- g. Record voltage indicated on DVM.
- h. Short circuit load. (Electronic load listed in Table 5-1 has short circuit switch.)
- i. Wait a few seconds only to allow DVM to settle. Reading on DVM should not differ from reading of step g by more than $10 \mu V$.

5-47 Source Effect (Line Regulation).

Definition: The change in the static value of dc output current (ΔI_{OUT}) resulting from a change in ac input voltage over the specified range from low line to high line, or from high line to low line.

5-48 To check source effect, proceed as follows:

- a. Connect test setup shown in Figure 5-2.
- b. Connect variable autotransformer between input power source and power supply ac power input.
- c. Adjust autotransformer for low line voltage (Paragraph 2-15).
- d. Turn VOLTAGE control fully clockwise.
- e. Turn on power supply and adjust CURRENT control until DVM reads 50 mV, indicating that current output is exactly 50A (maximum rated output current).
- f. Disconnect DVM from R_M and connect DVM to power supply sense terminals.
- g. Adjust resistance of load until DVM reads exactly 5V. Ensure that power supply remains in constant-current mode by checking CC light.
- h. Disconnect DVM from power supply sense terminals and reconnect DVM across R_M .
- i. Record voltage indicated on DVM.
- j. Adjust autotransformer for high line voltage.
- k. Reading on DVM should not differ from reading of step i by more than $10 \mu V$.

5-49 PARD (Ripple and Noise).

Definition: The residual ac current superimposed on the dc output of a regulated power supply. Ripple and noise measurement may be made at any input ac line voltage combined with any dc output voltage and load current within the supply's rating.

5-50 Most of the instructions pertaining to pickup problems associated with constant-voltage ripple and noise measurement also apply to the measurement of constant-current ripple and noise. The current probe listed in Table 5-1 clips on one of the load leads.

5-51 To check the ripple and noise, proceed as follows:

- a. Connect test setup shown in Figure 5-7.
- b. Rotate VOLTAGE control fully clockwise.

- c. Turn on supply and adjust CURRENT control and load so that the front-panel meters indicate 50 A and 20 V.
- d. The observed ripple and noise should be less than 25 mA rms.

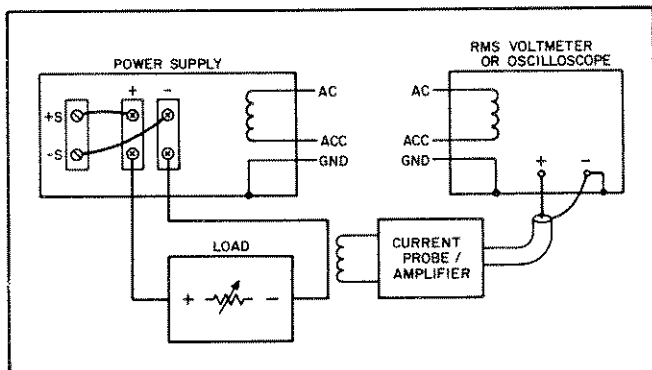

Figure 5-7. Constant-Current Ripple and Noise Measurement Test Setup

5-52 TROUBLESHOOTING

WARNING

Maintenance described herein is performed with power supplied to the instrument, and protective covers removed. Such maintenance should be performed only by service-trained personnel who are aware of the hazards involved (for example, fire and electrical shock). Energize the power supply through an isolation transformer to lessen the danger of electrical shock from contacting an energized circuit while contacting the instrument frame or other earth ground. (The isolation transformer must have a power rating of at least 4 kVA.) The safest practice while working on energized circuits is to disconnect power, make or change test connections, and then reapply power.

A red LED (DS1) on the main board lights to indicate that the input bus is energized. DS1 is included in the event the relay K1 contacts are stuck or welded closed. In this case, the input bus remains energized even when the LINE switch is turned off. DS1 goes out when the input bus voltage drops below approximately 80 Vdc. Some components are at ac line potential even with the LINE switch off.

5-53 Before attempting to troubleshoot this instrument, ensure that the fault is with the instrument itself and not with an associated circuit. The performance test enables this to be determined without having to remove the covers from the supply.

5-54 The most important aspect of troubleshooting is the formulation of a logical approach to locating the source of trouble. A good understanding of the principles of operation is particularly helpful, and it is recommended that Section IV of this manual be reviewed before attempting to troubleshoot the unit. Often the user will then be able to isolate a problem simply by using the operating controls and indicators. Once the principles of operation are understood, refer to the following paragraphs.

5-55 Section VII contains a schematic diagram and information concerning the voltage levels and waveforms at many of the important test points. Section VII also includes component location diagrams to help the user locate the unit's components and test points. Most of the test points used for troubleshooting the supply are located on the control board test "fingers", which are readily accessible at the top of the board.

CAUTION

To avoid damaging the 6012A, be careful not to short circuit test points together. The safest practice is to turn the 6012A off while connecting and disconnecting test instruments.

5-56 If a component is found to be defective, replace it and re-conduct the performance test. When a component is replaced, refer to the repair and adjustment portions of this section. It may be necessary to perform one or more of the adjustment procedures after a component is replaced.

5-57 Initial Troubleshooting Procedures

5-58 If a problem occurs, follow the steps below in sequence:

- a. Check that input power is available, and check the power cord and rear-panel circuit breaker. If breaker trips while power is on, or if breaker is found to be tripped at any time for unknown reasons, refer to Figure 5-11, Slow Start Procedure.

CAUTION

To prevent excessive inrush current, do not manually operate relay K1 on main board.

- b. Check that straps on the rear-panel terminal strip are properly connected.
- c. Check that all connections to the power supply are secure and that circuits between the supply and external devices are not interrupted.

5-59 **Troubleshooting Test Setup.** Before continuing with troubleshooting, proceed as follows:

- a. Turn off supply and disconnect all loads.

NOTE:
 1. IF FAILURE IS ACCOMPANIED BY SMOKE, AND/ OR NOISE, GO TO SLOW START PROCEDURE REGARDLESS OF WHETHER CBI IS TRIPPED.
 2. NUMBERS IN BRACKETS [] REPRESENT WAVEFORMS IN FIGURE 7-8.

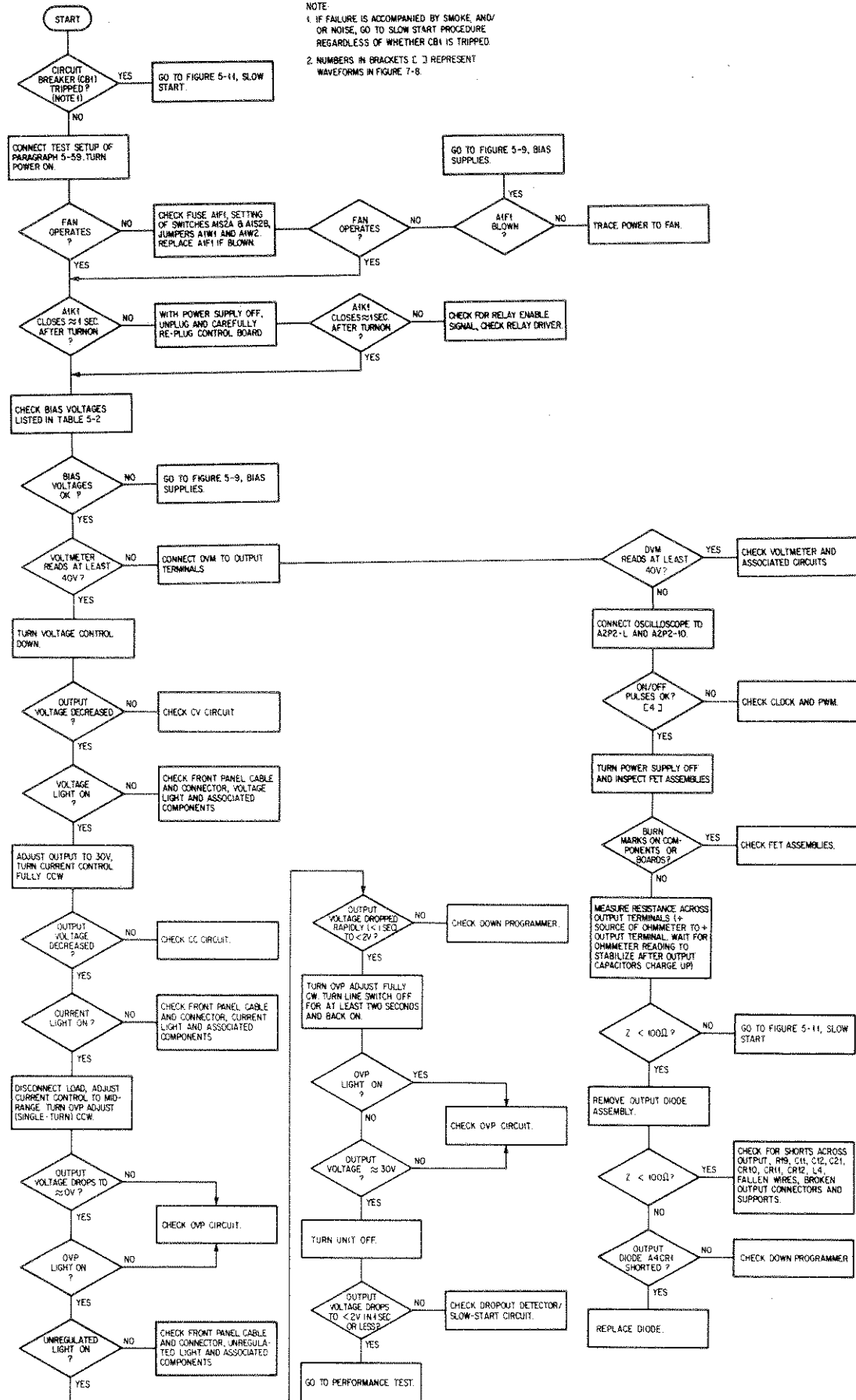

Figure 5-8. Overall Troubleshooting Tree.

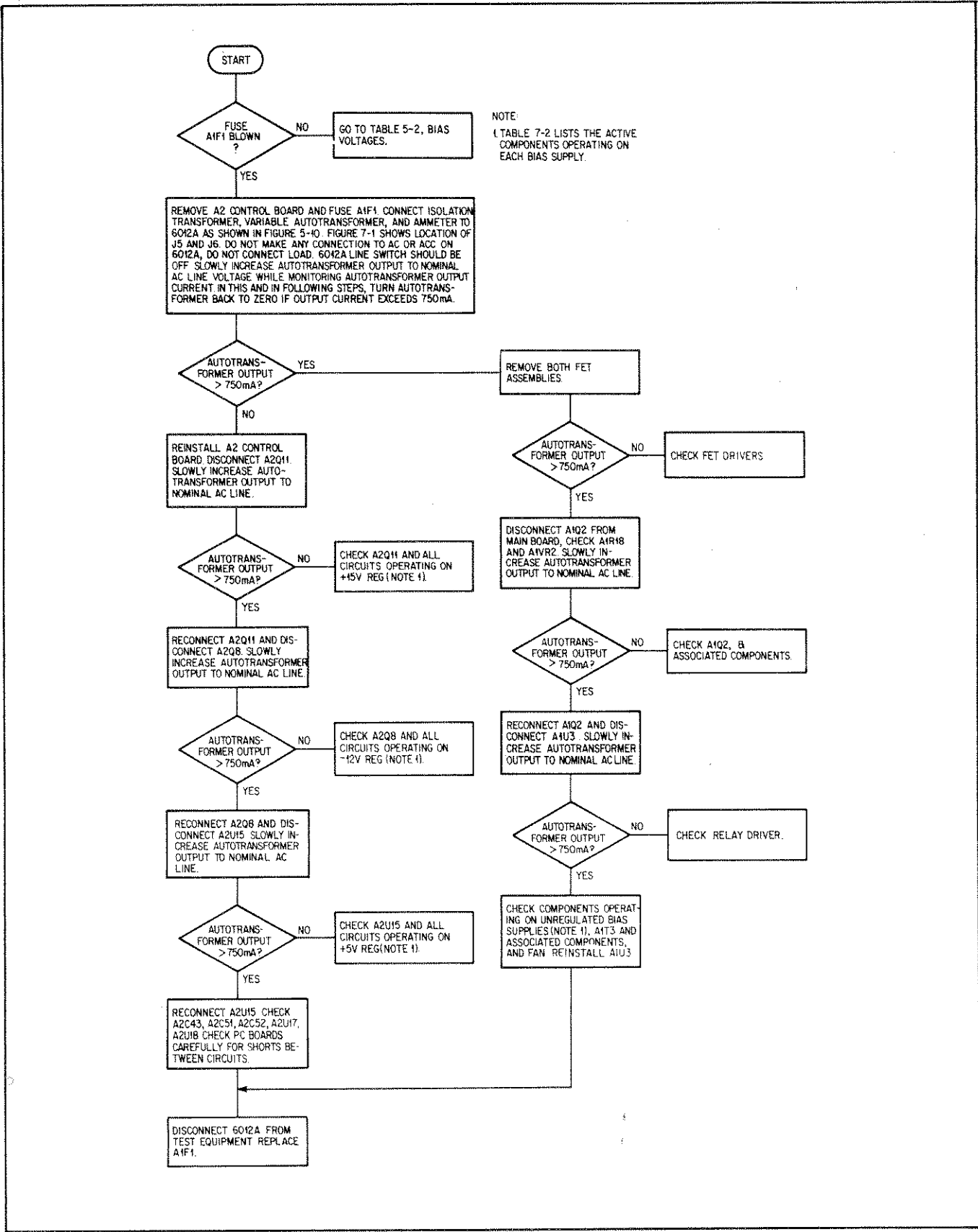

Figure 5-9. Troubleshooting Bias Supplies

- b. Connect a 50-ohm 40-watt load resistor across output terminals.
- c. Connect a digital voltmeter (DVM) across output terminals to monitor output voltage.
- d. Turn VOLTAGE and CURRENT controls to mid-range (5 turns), and OVP ADJUST control to maximum (fully CW).
- e. Remove top cover.
- f. An extender card, HP Part No. 5060-2809, can be used with the A2 Control Board to allow easy access to components.

5-60 Overall Trouble Isolation

5-61 Once the test setup is arranged, proceed to the overall troubleshooting tree in Figure 5-8. This tree will isolate trouble to a particular circuit. Table 5-3 provides information that the user who understands the operation of the circuit as described in Section IV can use with standard troubleshooting procedures to locate the trouble.

5-62 The following notes apply to all troubleshooting procedures.

1. Before removing or replacing components, turn power off and disconnect ac power cable.
2. Allow two minutes for capacitors to discharge before making resistance checks or removing components in primary circuit.
3. Unless otherwise noted, all voltages measured with respect to bias common (available at A2U15 case).
4. Numbers in brackets refer to waveforms shown in Figure 7-8.

5. The troubleshooting trees and table provide general guidelines to help isolate trouble. They will not isolate all possible troubles. The user should use signal tracing and other standard troubleshooting techniques to identify faulty components. The user is responsible for connecting and adjusting meters, oscilloscopes, etc. properly.

6. Before replacing a component, check connections to the component and ensure that bias voltages to the component are correct.

7. After isolating and correcting a problem, go back to beginning of troubleshooting tree.

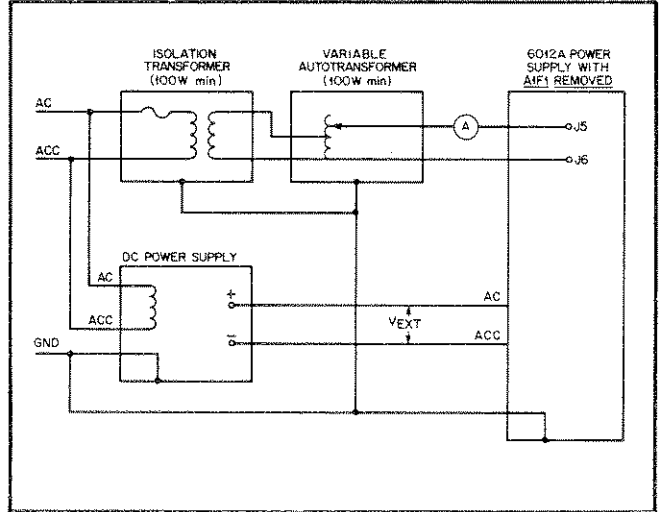

Figure 5-10. Slow Start Setup

Table 5-2. Bias Voltage Check

Bias Voltage	Measurement Point	Normal Range	Check These Components
+5V Reg	Pin M	+4.75V to +5.25V	Check for presence of +5V Unreg (+12V to +19V, pin K). If absent, check A1T3 pins 8 and 10, A1CR7-8, A1C14, A1R18, A1VR2. If present, check A2U15.
+15V Reg	Pin 12	+14.10V to +15.90V	Check for presence of +15V Unreg (+19V to +31V, pin D). If absent, check A1T3 pins 7 and 11, A1U4, A1C16. If present, check A2Q11, A2U18, A2R149, A2R150, A2R158, A2R159, A2R24, A2R29, A2VR6, A2C46.
-12V Reg	Pin P	-12.96V to -11.04V	Check for presence of -12V Unreg (-19V to -31V, pin 2). If absent, check A1C15. If present, check A2Q8, A2U17, A2R142, A2R143, A2R156, A2R157, A2C45.
All bias voltages measured at control board test fingers (P2) with respect to bias common at pin E or at A2U15 case. Table 7-2 lists semiconductor components operating on each bias supply.			

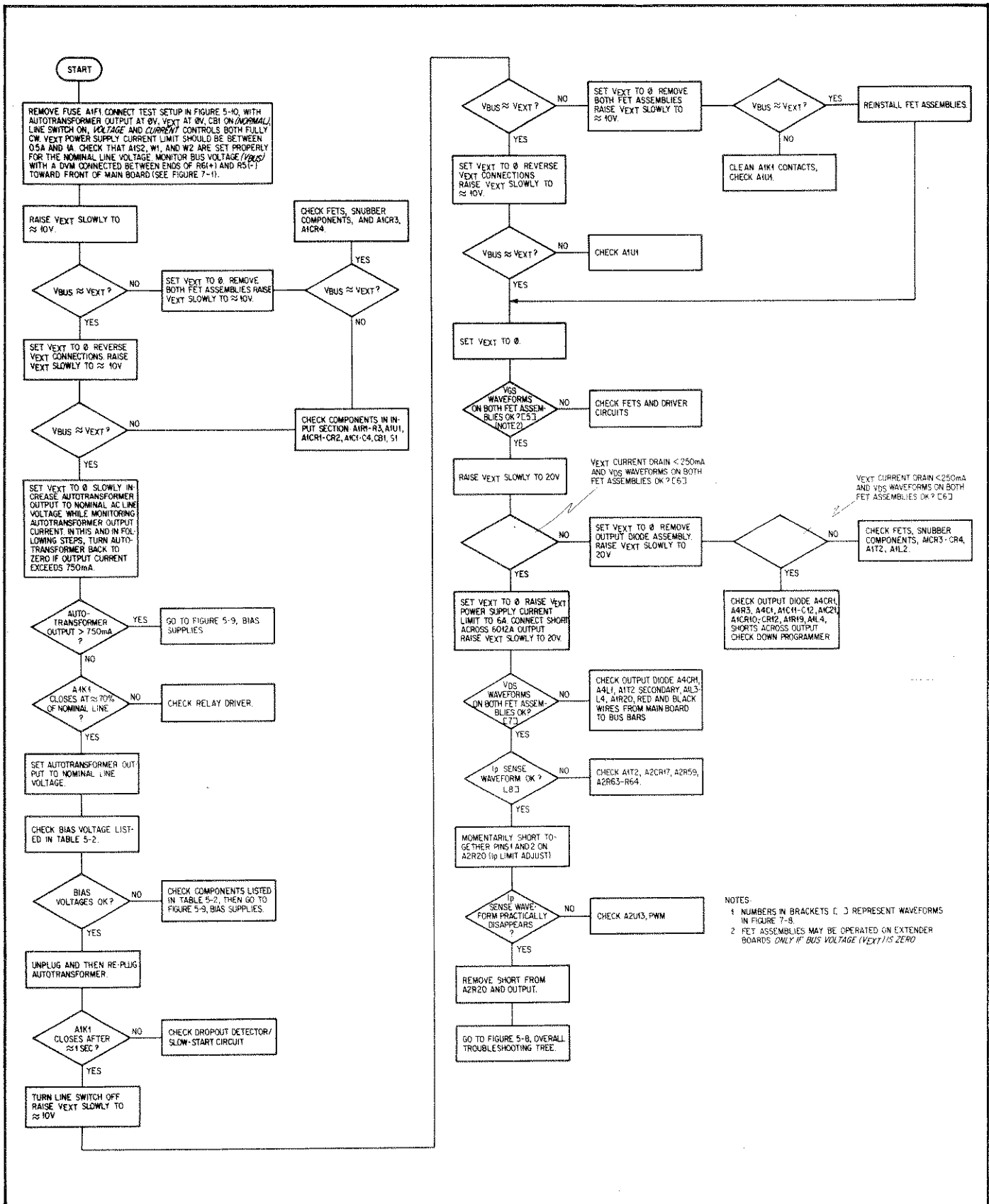

Figure 5-11. Slow Start Procedure

Table 5-3. Troubleshooting

After using the overall troubleshooting tree (Figure 5-8), bias supplies troubleshooting tree (Figure 5-9), and slow-start procedure (Figure 5-11) to isolate a fault to a particular circuit, use the following guidelines with the schematic and standard troubleshooting techniques to locate the fault.

Relay Driver

1. DC voltage across A1C8 should be 130 to 175 volts.
2. Approximately one second after ac power is applied, dc voltage from pin 1 to pin 2 on A1U2 should be +1.2 to 1.7 volts, dc voltage across A1VR1 should be <3 volts, and A1Q1 V_{BE} should be $\approx +0.7V_{dc}$. A1Q1 V_{CE} should be < 1 volt.
3. *With no load connected to output*, shorting pin 1 to pin 2 on A1U2 should cause relay to open.

Clock and PWM

1. Check for 320kHz [1] and 20kHz [2] clock signals.
2. Check if PWM (A2U9A-5) is inhibited by inputs to A2U10.
3. Check on and off pulses [4] at A2P2-L and A2P2-10.

FET Assemblies

To isolate a fault to either the FETs or driver circuits, remove all FETs and replace one FET on each assembly with a 3300pF capacitor connected between the gate- and source- lead pins (heatsink should not be connected for this test). Observe all precautions given in Paragraph 5-72 while handling FETs. If V_{GS} waveform [5] is correct with FETs removed, then FETs were bad. (Gate to drain resistance <1M Ω indicates bad FET.) Replace FETs in pairs on an assembly. If V_{GS} waveform remains bad with FETs removed, then driver circuits were bad. Check A3R10, A3U1-U2, A3T1, A3CR3. A fault in the driver circuits will usually damage the FETs on that assembly.

Down Programmer

1. With VOLTAGE control one turn CW and OVP ADJUST fully CW, output voltage should be $\approx +5V$ and anodes of A2CR26-29 should be $\approx +2.4V$. Otherwise, check cathodes of A2CR26-28 to determine which circuit is triggering down programmer.
2. With anodes of A2CR26-29 $\approx +2.4V$ and A2U19B inverting input (–, pin 6) $\approx +1.8V$ (A2U19B non-inverting input $\approx +0.6V$), A2U19B output should be $\approx 0V$ and A2Q12 and A4Q1 bases should be $\approx 0V$. Otherwise, check A2U19B, A2Q12, A4Q1 and associated components.

CV Circuit

1. Voltage from A7 to –S should vary from 0 to 5 volts as VOLTAGE control is varied from minimum to maximum. Otherwise, check VOLTAGE control and output of constant-current source A2Q1.
2. Trace signal through A2U3 and A2U6B. Amplifier output should be high when non-inverting input (+) is more positive than inverting input (–).
3. With A2U5 non-inverting input (+, pin 2) positive, A2U5 inverting input (–, pin 3) should be a positive-going ramp starting from 0 volts. Otherwise, check A2R88, A2R87, A2C32, A2R84, A2R55 and A2C31. As the dc level at A2U5-2 varies between 0 and +1.5 volts, the pulse width at A2U9-5 should vary from ≈ 1 to 20 μs . The ramp magnitude at A2U5-3 also varies proportionally.
4. A2U3 output interfaces with down programmer through A2VR7 and A2CR28. Check that A2U6-5 is not loaded down.

Table 5-3. Troubleshooting (Continued)

CC Circuit

1. Voltage from A3 to A5 should vary from 0 to 5 volts as CURRENT control is varied from minimum to maximum. Otherwise, check CURRENT control and output of constant-current source A2Q4.
2. Trace signal through A2U6C. Amplifier output (pin 8) should be high when non-inverting input (+, pin 10) is more positive than inverting input (-, pin 9).
3. (Same as step 3 in CV Circuit)
4. A5U2 output (pin 6) should vary from 0 to 5 volts as 6012A output current varies from 0 to 50A. Otherwise, check A2U2 and associated components, including adjustment potentiometers A2R22 and A2R23.
5. A2U6A output (pin 1) should always be high ($\approx +15V$) during normal operation (output current $\leq 52A$). A2U6A non-inverting input (+, pin 3) should always be $+5.5V$.
6. A2U1B output (pin 7) should be within + or $-100mV$ at dc. A2U1A output (pin 1) should be within + or $-1.5V$ at dc. This dc level should not affect the dc level at A2U6C pin 9; otherwise check A2C3 and A2R7. If user injects a sinusoid between A3 and A5, ac gain from +S to A2U1A pin 1 (both referenced to A5) should be unity at 22Hz, 2.7 at 60Hz, and 5.5 at 120Hz.

OVP Circuit

1. With OVP ADJUST fully CCW, OVP light should be on, output voltage should be $\leq 2V$, and test point A2P2-9 should be low. Otherwise, check A5R4, A2J2 and cable from front panel, A2U19A, A2Q9, A2Q10, A2VR5, and associated components.
2. When OVP is tripped, A2U19A non-inverting input (+, pin 3) should be more positive than inverting input (-, pin 2), and A2U19A output (pin 1) and A2Q10 base should be high.
3. With OVP ADJUST fully CW, turn power supply off for at least two seconds and then back on. Test point A2P2-9 should be high, OVP light should be off, and output voltage is determined by setting of VOLTAGE control.

Bias Voltage Detector/Dropout Detector

1. A full-wave rectified 120Hz sine wave of approximately 16 volts peak should be present at A2P1-16. Otherwise check that A2 control board is properly aligned and fully seated, and check A1CR6 and A1CR9.
2. Output of dropout detector ramp circuit at A2U13B pin 1 should be $\approx +5V$ (use high impedance voltmeter, $\geq 10M\Omega$).
3. Output of slow-start ramp circuit at A2U13C pin 14 should be $\approx 0V$.
4. A2U16A pin 8 should be $\approx +0.7V$.
5. A2U16A pin 7 should be $< +0.2V$.

5-63 REPAIR AND REPLACEMENT

WARNING

Disconnect the power supply from the ac line and wait two minutes before performing any repair or replacement procedures.

5-64 Outside Cover Removal

5-65 To remove top cover, remove the three screws, one at each side and one at center of rear panel, that secure top cover to instrument. Lift back of cover, slide cover to the rear, and lift off.

5-66 To remove bottom cover, proceed as follows:
a. Remove two pan-head screws that secure cover to rear panel (one at each side).
b. Remove two flat-head screws from front edge of bottom cover.

c. Remove four screws that secure two carrying straps to sides of instrument.

d. Lift back of cover, slide cover to rear, and lift off. It is not necessary to remove instrument feet.

5-67 A2 Control Board Removal

5-68 The control board is held in place by two screws through the side panel. To remove the control board, proceed as follows:

- a. Remove top cover.
- b. Disconnect all wires from rear-panel terminal block.
- c. Unplug cable from option card (if installed).
- d. Unplug cable from front panel.
- e. On side panel, remove two flat-head screws that secure control board to right-side panel.
- f. Grasp control board carefully and pull upward to unplug it from main board. Do not use spacers between control board and side panel to pull control board.
- g. To remove U15 from control board, first remove two screws that secure U15 case and heatsink to printed-circuit board. Then unsolder both U15 pins from board.

NOTE

When replacing U15, you must spread a thin layer of heatsink compound between U15 case and heatsink. Do not use any compound containing silicone. An organic zinc oxide cream, such as American Oil And Supply Company Heatsink Compound #100, is recommended. See Figure 5-12 for location of mounting hardware.

h. When replacing control board, carefully line up connector on bottom edge with socket on main board.

i. Carefully press control board down so it is properly aligned and fully seated in main-board socket. Control board is fully seated when printed-circuit board presses against both ends of main-board socket. Do not push down on any components on control board.

j. Replace two screws that secure control board to side panel.

k. Reconnect cable from front panel to J2 socket. Red tracer is to front of instrument (white dot on control board).

l. Reconnect cable from option card (if installed) to J1 socket. Red tracer is to front of instrument (white dot on control board. (Incorrect replacement will damage option board.)

m. Reconnect any wires disconnected from rear-panel terminal block.

5-69 A3 FET Boards and A4 Output Diode Board Removal

5-70 The two FET board assemblies and the output diode board assembly plug into sockets on the main board and are held in place by the heatsink cover, which is screwed to the fan bracket. To remove these assemblies, proceed as follows:

WARNING

Wait two minutes for input capacitors to discharge before removing heatsink cover or performing any maintenance procedure.

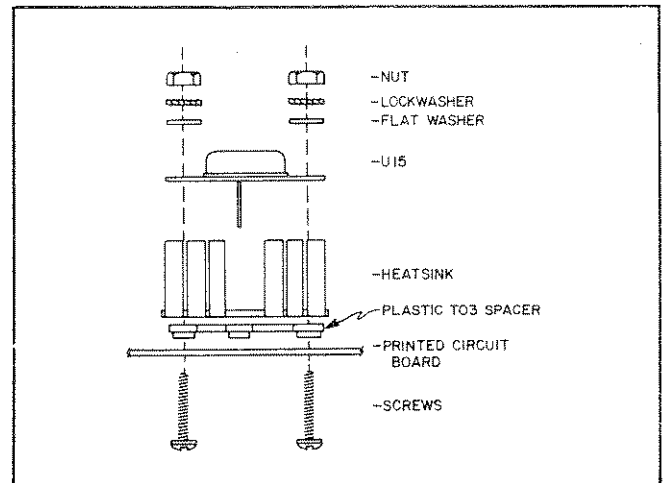

Figure 5-12. A2U15 Mounting Hardware

a. Remove eight screws from heatsink cover (two screws hold heatsink cover to fan bracket, six screws fasten heatsink cover to FET board and output diode board assemblies), and lift cover off.

b. Pull assembly upward to unplug it from main board.

c. When replacing assemblies, be certain to replace assemblies in proper locations. With user facing front panel, the FET board assemblies fit in left and center sockets, with printed-circuit board facing left. The output diode board assembly fits in right socket, with printed-circuit board facing right.

d. After replacing FET board and output diode board assemblies, replace heatsink cover. Be certain all six plastic inserts, two in each heatsink, are properly located under screw holes in heatsink cover. Start screws into plastic heatsink inserts carefully, and do not over-tighten.

CAUTION

To prevent heatsinks from shorting together, do not operate power supply without heatsink cover in place. Be certain that all six plastic heatsink inserts are properly located under heatsink cover holes and engaged by six heatsink cover screws.

5-71 FET Board Disassembly

5-72 To disassemble a FET board, proceed as follows:

- a. Unsolder both wires from thermostat.

b. Remove four screws that secure FETs and heatsink to printed-circuit board.

c. FETs plug into pins that are soldered to printed-circuit board. Do not unsolder these pins. Carefully unplug each FET.

CAUTION

To avoid damage to FETs, handle with care when out of circuit. Use a grounding strap to avoid static discharge into gate. Avoid touching gate or source pins. FETs should be replaced in pairs; if one FET on a FET board has to be replaced, replace both.

NOTE

When replacing FETs or thermostat, you must spread a thin layer of heatsink compound between component and heatsink. See note following Paragraph 5-68 step g for recommended compound.

d. Before re-assembly of FET board, ensure that plastic insulators for FET leads remain in heatsink. Figure 5-13 shows TO3 component mounting.

e. Ensure that four pins for FET leads are standing straight up from printed-circuit board.

f. Mate printed-circuit board with heatsink, ensuring that four FET-lead pins fit into four holes in heatsink.

g. Carefully mate FET leads with pins extending into heatsink from printed-circuit board.

h. Replace four screws that secure FETs and heatsink to printed-circuit.

i. Re-solder wires to thermostat.

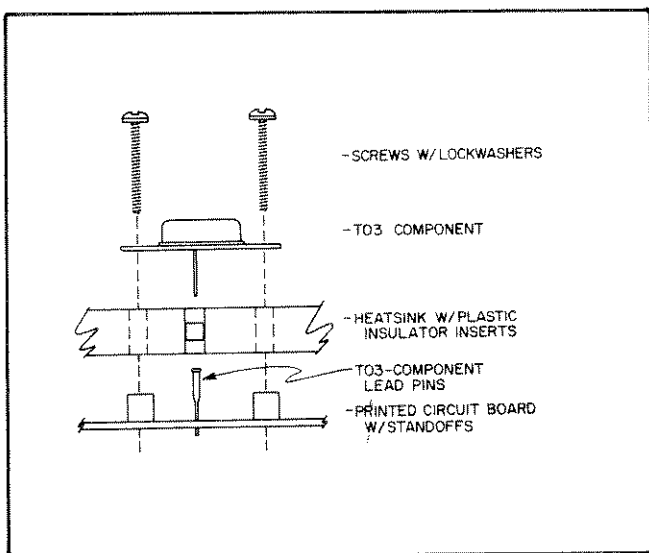

Figure 5-13. TO3 Components (A3Q1, A3Q2, A4Q1) Mounting

5-73 Output Diode Board Disassembly

5-74 To disassemble the output diode board, proceed as follows:

a. Unsolder both wires from thermostat.

b. Unsolder both wires from output diode at points A and B on printed-circuit board.

c. Remove three screws, two of which secure Q1, that secure heatsink to printed-circuit board.

d. Q1 plugs into pins that are soldered to printed-circuit board. Do not unsolder these pins. Carefully unplug Q1.

NOTE

When replacing Q1, output diode, or thermostat, you must spread a thin layer of heatsink compound between component and heatsink. See note following Paragraph 5-68 step g for recommended compound.

e. Before re-assembly of output diode board, ensure that plastic insulators for Q1 leads remain in heatsink. Figure 5-13 shows TO3 component mounting.

f. Ensure that two pins for Q1 leads are standing straight up from printed-circuit board.

g. Mate printed-circuit board with heatsink, ensuring that two Q1-lead pins fit into two holes in heatsink.

h. Carefully mate Q1 leads with pins extending into heatsink from printed-circuit board.

i. Replace three screws that secure Q1 and heatsink to printed-circuit board.

j. Re-solder output diode wires to points A and B on printed-circuit board. Ensure good solder connections, because these connections carry the full output current, up to 50A.

5-75 A1 Main Board Removal

5-76 The main board is held in place by 16 #6-32 screws (see Figure 7-1). These 16 screws include two that secure K1 to the main board, four that secure T2 to the main board, and two that secure T3 to the main board. To remove the main board, proceed as follows:

NOTE

Certain components can be accessed through bottom chassis without removing main board. See Paragraph 5-79. Relay K1 can be removed to allow access to components under K1 without removing main board. See Paragraph 5-77.

a. Remove control board, both FET board assemblies, and output diode board assembly.

b. Remove red and black wires from output bus bars.

c. Remove and tag any wires connected to main board from components not on main board. Note that this step is required only if main board is to be completely removed from unit. Main board can be pulled up and turned on its side without removing any wires.

d. Remove 16 mounting screws (see Figure 7-1 for locations).

e. Lift board up 1/2 inch so capacitor bracket clears spacers under four large filter capacitors, and tilt board to allow access to bottom of board.

5-77 Relay K1 Removal

5-78 Resistors R1, R2 and R3 are mounted under relay K1 on main board. To remove K1, proceed as follows:

a. Remove and tag six wires connected to K1 from main board (Figure 7-1 shows wire colors and locations).

b. Remove two screws that secure K1 to main board (Figure 7-1 shows screw locations).

5-79 Component Access Through Bottom Chassis

5-80 Figure 5-14 shows components on the main board that can be accessed through holes in the bottom chassis.

5-81 Front Panel Removal

5-82 The front-panel controls and indicators are wired to a printed-circuit board mounted directly behind the front panel. To remove the front panel, proceed as follows:

a. Remove top cover and disconnect front-panel ribbon cable from J2 on control board.

b. Remove snap-out plastic trim strip that extends across top of unit above front panel.

c. Remove two flat-head screws in channel from which trim strip was removed (one at each end). Other screws may show through holes in the front chassis; do not remove them.

d. Turn unit bottom up and repeat step c for bottom of front panel.

e. Turn unit top up and carefully pull front panel out from unit.

f. Remove two screws at top and three screws at bottom that secure front panel to bracket behind front panel.

g. Disconnect ground wire from left side of chassis.

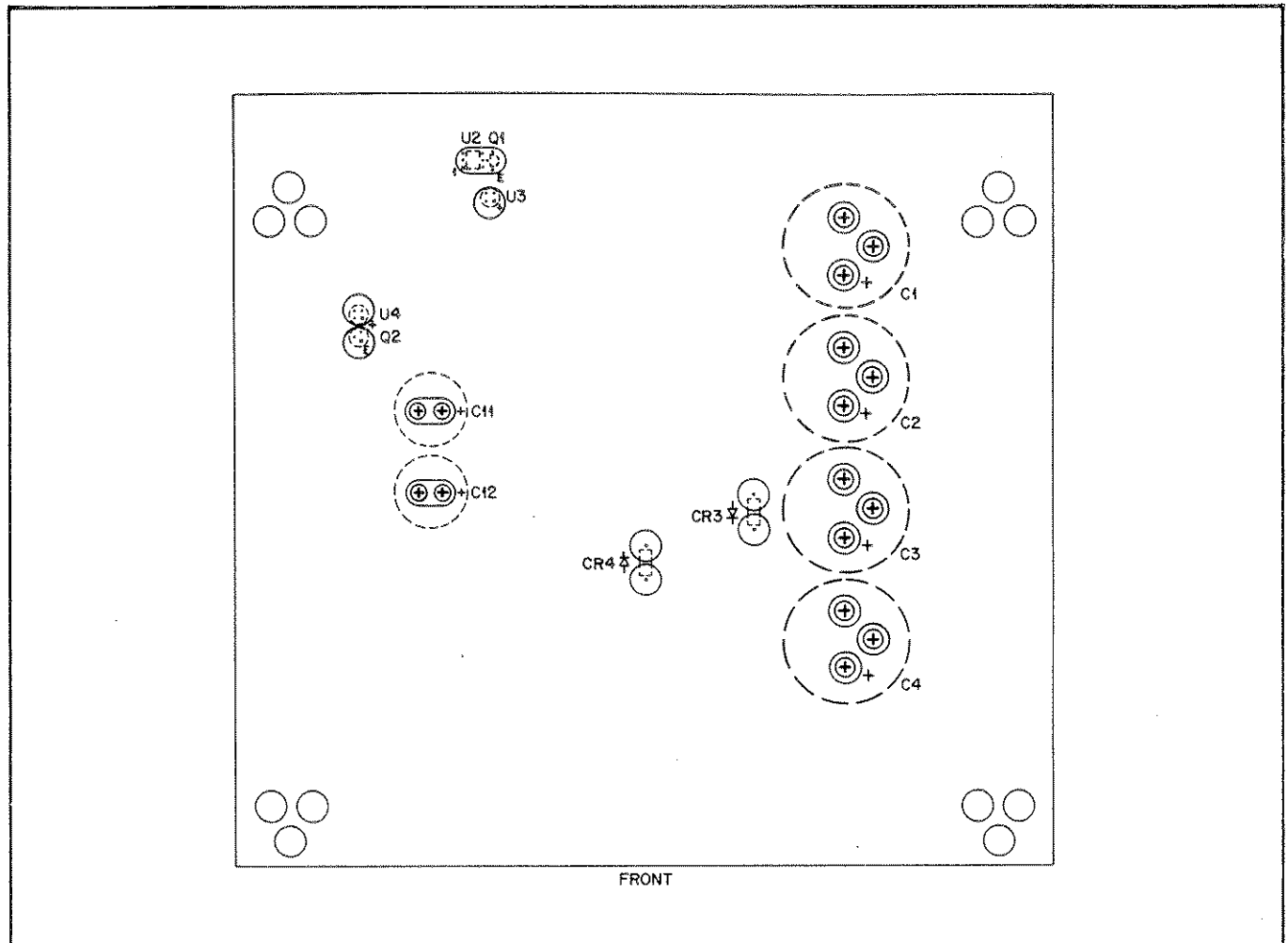

Figure 5-14. Component Access Through Bottom Chassis

h. Remove four screws that secure printed-circuit board to bracket. Be careful not to break connections to front-panel potentiometers or meters.

i. When replacing front panel remember to put ribbon cable through hole in right side of fan bracket, and reconnect ground wire.

j. Plastic trim strip across top of front panel should be replaced with channel in strip toward rear of instrument.

5-83 Replacement Parts

5-84 Section VI of this manual contains a list of replacement parts. If the part to be replaced does not have a standard manufacturer's part number, it is a special part and must be obtained directly from Hewlett-Packard. After replacing a component, refer to Table 5-4 for adjustments that may be necessary.

5-85 Some components are mounted with spacers, insulators, etc. on leads. Be certain to note location of all mounting pieces before removing component, and replace all pieces in proper location.

5-86 ADJUSTMENT AND CALIBRATION

5-87 Adjustment and calibration may be required after performance testing, troubleshooting, or repair and replacement. Perform only those adjustments that affect the operation of the faulty circuit. Table 5-4 lists symptoms indicating that adjustment is necessary. If two or more adjustments will be made, they should be performed in the order in which they are listed in Table 5-4.

5-88 Unless otherwise stated, all adjustments are performed with the power supply strapped as shown in Figure 3-3. The unit should have been turned on for at least 30 minutes before performing any adjustments to allow it to reach normal operating temperature.

WARNING

The power supply should be turned off while making and removing connections to the rear-panel terminals.

5-89 All adjustment potentiometers are located along the top edge of the control board. Figure 5-15 shows the location of the adjustments as viewed from the left of the instrument.

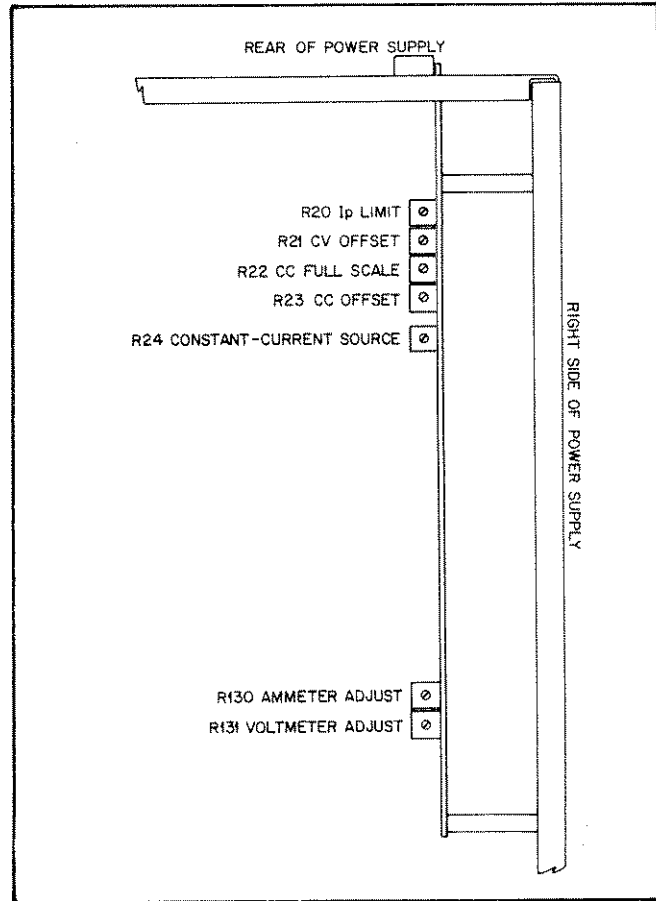

Figure 5-15. Location of Adjustment Potentiometers

5-90 Meter Zero Adjustment

5-91 The meter pointers must point to zero on the meter scales when the instrument is at normal operating temperature in its normal operating position, and turned off. The same procedure is used for both meters. To zero a meter, proceed as follows:

- a. Turn power supply off and wait three minutes for

Table 5-4. Adjustments

Adjustment	Symptom Indicating Adjustment Necessary
A2R20 Ip Limit	Output unregulated even though operating within power limit (set too low), or provides more than 25V at 50A (set too high)
A2R21 CV Offset	0-volt programming input does not produce 0-volt output
A2R22 CC Full Scale	5-volt programming input does not produce 50-amp output
A2R23 CC Offset	0-volt programming input does not produce 0-amp output
A2R24 Constant-Current Source	2.5k resistive programming input does not produce 60-volt output
A2R130 Ammeter Adjust	Front-panel ammeter does not agree with output current indicated by DVM connected across shunt in series with output
A2R131 Voltmeter Adjust	Front-panel voltmeter does not agree with DVM connected to output terminals

power supply capacitors to discharge completely.

b. Insert a small-blade screwdriver in meter-adjust screw (about one inch below meter face) and turn screw until pointer points to zero mark on scale.

5-92 Ip Limit Adjustment

5-93 The I_p limit adjustment ensures that the power supply will provide maximum output power under worst-case conditions. With power supply turned off, proceed as follows:

a. Connect load and shunt to power supply output terminals as in Figure 5-2. Operate load in constant current mode, and adjust load to draw more than 52A.

b. Connect digital voltmeter (DVM) across input bus. Input bus voltage can be monitored between ends of R6 (+) and R5 (-) toward front of instrument on main board (see Figure 7-1). Note that this voltage is referenced to the ac line.

c. Connect a second DVM across shunt.

d. Connect power supply ac input to a variable autotransformer.

e. Turn VOLTAGE and CURRENT controls both fully clockwise, and turn I_p limit adjust (A2R20) fully counterclockwise.

f. With autotransformer set at zero volts, turn power supply on. Increase autotransformer voltage until input bus voltage is 300 Vdc.

g. Adjust A2R20 for 52 mV across shunt (52A output).

h. Decrease load current for 50 mV across shunt (50A output).

i. Disconnect DVM from shunt and connect DVM across output terminals.

j. Adjust A2R20 for 22V output $\pm 0.1V$.

k. Adjust autotransformer for 240 Vdc input bus voltage.

l. Repeat steps j and k until A2R20 is adjusted for 22V output with 240V bus voltage. (Output current should remain at 50A during steps j and k.)

m. Turn off power supply and disconnect load, shunt, and autotransformer. Disconnect DVM from input bus.

5-94 Constant Voltage Offset Adjustment

5-95 The constant voltage offset adjustment is made with a 50 Ω , 40W load connected to the power supply. Proceed as follows:

a. Connect digital voltmeter (DVM) between A7 and -S terminals.

b. Turn power supply on and adjust VOLTAGE control for 10 mV reading on DVM.

c. Disconnect DVM from A7 and -S and connect DVM across output terminals.

d. Adjust A2R21 for 120 mV $\pm 2mV$ on DVM. (Output voltage is 12x A7 voltage).

5-96 Constant Current Full Scale and Offset Adjustment

5-97 Proceed as follows:

a. Connect a 1 m Ω shunt across output terminals.

b. Turn on power supply.

c. Connect digital voltmeter (DVM) between A3 (+) and A5 terminals.

d. Adjust CURRENT control for 5V at A3.

e. Disconnect DVM from A3 and A5 and connect DVM across shunt.

f. Adjust A2R22 for 50 mV reading on DVM (50A output current).

g. Disconnect DVM from shunt and reconnect DVM across A3 and A5.

h. Adjust CURRENT control for 10 mV at A3.

i. Disconnect DVM from A3 and A5 and reconnect DVM across shunt.

j. Adjust A2R23 for 1 mV reading on DVM (100 mA output current.) If output current is initially zero amperes, there may be a few-second delay when A2R23 is turned up.

k. Repeat steps c through j as necessary until 5V between A3 and A5 produces 50A $\pm 0.2\%$ output current, and 10mV between A3 and A5 produces 100mA $\pm 5mA$ output current.

l. Turn off power supply and disconnect shunt.

5-98 Constant-Current-Source Adjustment

5-99 The constant-current-source adjustment is made with a resistor whose value is known within 0.1% connected directly between terminals A7 and -S on the rear panel. The nominal value of the resistor should be between 1 k and 2.7 k. A value of 1 k is recommended for ease of calculating current flow through the resistor. Proceed as follows:

a. Remove the strap between terminals A8 and A7.

b. Connect resistor between A7 and -S.

c. Connect digital voltmeter (DVM) across resistor.

d. Turn power supply on and adjust A2R24 for 2 mA $\pm 0.2\%$ through resistor. (For example, if a 1 k resistor is used, DVM reading of 2 V indicates 2 mA through resistor.)

e. Turn power supply off, disconnect resistor between A7 and -S, and reconnect strap between A8 and A7.

5-100 Ammeter Adjustment

5-101 The CC full scale and CC offset adjustments must be correct before adjusting the ammeter circuit. To adjust the ammeter circuit, proceed as follows:

a. Connect a 1 m Ω shunt across output terminals.

b. Connect digital voltmeter (DVM) across shunt.

c. Turn on power supply and adjust CURRENT control for 0.05 V $\pm 0.1mV$ on DVM (50 A $\pm 100mA$ output).

d. Adjust A2R130 for 50 A reading on front-panel ammeter.

e. Turn off power supply and disconnect shunt.

5-102 Voltmeter Adjustment

5-103 The CV offset and constant-current source adjustments should be correct before adjusting the voltmeter circuit. To adjust the voltmeter circuit, proceed as follows:

a. Connect digital voltmeter (DVM) across output terminals.

b. Turn on power supply and adjust VOLTAGE control for 60 V $\pm 120 mV$ reading on DVM.

c. Adjust A2R131 for 60 V reading on front-panel voltmeter.

SECTION VI REPLACEABLE PARTS

6-1 INTRODUCTION

6-2 This section contains information for ordering replacement parts. Table 6-4 lists parts in alpha-numeric order by reference designators and provides the following information:

- a. Reference Designators. Refer to Table 6-1.
- b. Hewlett-Packard Part Number.
- c. Total Quantity (TQ) used in that assembly.
- d. Description. Refer to Table 6-2 for abbreviations.
- e. Manufacturer's Federal Supply Code Number. Refer to Table 6-3 for manufacturer's name and address.
- f. Manufacturer's Part Number or Type.

6-3 Parts not identified by reference designator are listed at the end of Table 6-4 under Mechanical and/or Miscellaneous. The former consists of parts belonging to and grouped by individual assemblies; the latter consists of all parts not immediately associated with an assembly.

Table 6-1 Reference Designators

A	Assembly
B	Blower (fan)
C	Capacitor
CB	Circuit Breaker
CR	Diode
DS	Signaling Device (light)
F	Fuse
FL	Filter
J	Jack
K	Relay
L	Inductor
M	Meter
P	Plug
Q	Transistor
R	Resistor
S	Switch
T	Transformer
TB	Terminal Block
TS	Thermostat
U	Integrated Circuit
VR	Voltage Regulator (zener diode)
W	Wire (jumper)
Y	Oscillator

6-4 ORDERING INFORMATION

6-5 To order a replacement part, address order or inquiry to your local Hewlett-Packard sales office (see lists at rear of this manual for addresses). Specify the following information for each part: Model, complete serial number, and any Option or special modification (J) numbers of the instrument; Hewlett-Packard part number; circuit reference designator; and description. To order a part not listed in Table 6-4, give a complete description of the part, its function, and its location.

Table 6-2. Description Abbreviations

AL	Aluminum
AWG	American Wire Gauge
CAP	Capacitor
CC	Carbon Composition
CER	Ceramic
C-F	Capacitor
CONN	Connector
DIO	Diode
DPDT	Double Pole Double Throw
F	Film
FC	Carbon Film/ Composition
FET	Field Effect Transistor
F.S.	Full Scale
FW BRDG	Full Wave Bridge
GEN PRP	General Purpose
IC	Integrated Circuit
MET POLY	Metallized Poly- propylene
MO	Metal Oxide
NO	Normally Open
POLY E	Polyester
PW	Power Wirewound
PWR	Power
RECT	Rectifier
RES	Resistor
SI	Silicon
SW-PB	Switch, Pushbutton
SW-SL	Switch, Slide
SW-THRM	Switch, Thermal
TA	Tantalum
TBAX	Tube Axial
TRMR	Trimmer
VAR	Variable
XFMR	Transformer
XSTR	Transistor
ZNR	Zener

Table 6-3. Code List of Manufacturers

Code	Manufacturer	Address
00853	Sangamo Electric Company	Pickens, SC
01121	Allen Bradley Company	Milwaukee, WI
01295	Texas Instruments Inc., Semicon Comp. Division	Dallas, TX
01686	RCL Electronics Inc.	Manchester, NH
02111	Specctrol Electronics Corporation	City of Ind, CA
03508	G.E. Company, Company, Semiconductor Products Department	Auburn, NY
04713	Motorola Semiconductor Products	Phoenix, AZ
06776	Robinson Nugent Inc.	New Albany, IN
07263	Fairchild Semiconductor Division	Mountainview, CA
12954	Siemens Corporation Components Group	Scottsdale, AZ
14604	Elmwood Sensors, Inc.	Cranston, RI
14936	General Instrument Corporation, Semicon Products	Hicksville, NY
16299	Corning Glass Works, Component Division	Raleigh, NC
19701	Mepco/Electra Corporation	Mineral Wells, TX
20932	Emcon Division ITW	San Diego, CA
24546	Corning Glassworks	Bradford, PA
27014	National Semiconductor Corporation	Santa Clara, CA
27167	Corning Glassworks	Wilmington, NC
28480	Hewlett-Packard	Palo Alto, CA
2M627	R-Ohm Corporation	Irvine, CA
31918	ITT Schadow	Minneapolis, MN
32997	Bourns, Inc.	Riverside, CA
3L585	RCA Corporation, Solid State Division	Somerville, NJ
4N833	ETRI Inc.	Monroe, NC
54473	Matsushita Electric Corporation of America	New York, NY
56289	Sprague Electric Company	North Adams, MA
71400	Bussman Division of McGraw Edison Company	St. Louis, MO
72982	Erie Technological Products, Inc.	Erie, PA
73138	Beckman Instruments, Inc., Helipot Division	Fullerton, CA
82389	Switchcraft, Inc.	Chicago, IL
84411	TRW Capacitor Division	Ogallala, NE
91637	Dale Electronics, Inc.	Columbus, NE
CO633	Rifa	Bromma, Sweden
†	Wima	Mannheim, Germany

Table 6-4. Replacement Parts

Ref. Desig.	HP Part No.	TQ	Description	Mfr. Code	Mfr. Part No.
A1			Main Board Assembly		
C1-4	0180-2889	4	cap 3400 μ F 200V -10 + 50%	28480	
C5,6	0160-4355	2	cap .01 μ F \pm 10% 250Vac	C0633	PME271Y510
C7,17	0160-5187	2	cap 0.15 μ F 600V	28480	
C8	0180-0426	1	cap 22 μ F -10 + 100% 250Vdc	31918	EN12.35N22/250
C9,10	0160-3969	2	cap .015 μ F \pm 20% 250Vac	C0633	PME271Y515
C11,12	0180-3049	2	cap 2600 μ F -10 + 50% 75Vdc	00853	101262T075AJ2A
C13	0160-4281	1	cap 2200pF \pm 20% 250Vac	C0633	PME271Y422
C14	0180-1916	1	cap 2000 μ F -10 + 100% 28Vdc	56289	(TYPE 680) D44591-DFP
C15,16	0180-2628	2	C-F 220 μ F + 50-10% 50V	54473	ECE-A50V220L
CR1,2, 10-12	1901-0759	5	dio- IN5406	14936	IN5406
CR3,4	1901-1087	2	dio-pwr rect 600V 3A	04713	MR856
CR5	1901-0028	1	dio-pwr rect 400V 10A	04713	SR1358-9
CR6,9	1901-0050	2	dio-switching	07263	FDH6308
CR7,8	1901-0327	2	dio-pwrrect 200V 1A	03508	A14B
DS1	1990-0325	1	LED-visible	28480	
F1	2110-0063	1	fuse .75A 250V	71400	AGC-3/4
J1-4	1251-6488	4	conn.-pc edge	28480	
K1	0490-1267	1	relay DPST	28480	
L1	06012-80096	1	choke-input	28480	
L2		1	choke ass'y, consists of:		
	9170-0707	2	core-ferrite	28480	
	06012-80003	1	wire-snobber	28480	
L3		1	choke ass'y, consists of:		
	9170-0721	1	core-magnetic	28480	
	06012-80095	1	choke-output	28480	
L4		1	choke ass'y consists of:		
	9170-0061	1	core-ferrite	28480	
	06012-80004	1	choke	28480	
L5	9140-0082	1	RF choke 15 μ H \pm 10%	28480	
Q1	1854-0575	1	xstr NPN si	27014	ST48090A
Q2	1854-0448	1	xstr NPN si	04713	SS1147
R1,3	0811-1892	2	res 3 Ω \pm 5% 10W ww	91637	RS-10
R2	0811-1898	1	res 20 Ω \pm 5% 10w ww	01686	T10-78
R4	0686-3015	1	res 300 Ω 5% 0.5W cc	01121	EB3015
R5,6	0811-1914	2	res 5k \pm 5% 10W ww	91637	RS-10
R7-12	0686-0275	6	res 2.7 Ω \pm 5% 0.5W cc	01121	EB27G5
R13	0811-1803	1	res 1.3k \pm 5% 3W ww	01686	T2B-79
R14,15	0686-1645	2	res 160k 5% 0.5W cc	01121	EB1645
R16	0686-1005	1	res 10 Ω 5% 0.5W cc	01121	EB1005
R17	0683-2035	1	res 20k 5% 0.25W cc	01121	CB2035
R18	0686-4715	1	res 470 5% 0.5W cc	01121	EB4715
R19	0811-1559	1	res 6k \pm 5% 5W ww	91637	RS-5
R20	06012-80005	1	res-monitor 3.7m Ω	28480	
R21	0698-3428	1	res 14.7 Ω \pm 1% 0.125Wf	16299	NK4H
S2	3101-1914	1	sw-sl 2-DPDT	82389	11E-1060
T1	5080-1937	1	xfmr-current lim	28480	
T2	06012-80093	1	xfmr-pwr	28480	
T3	06012-80090	1	xfmr-bias	28480	
U1	1906-0218	1	dio-fw brdg 600V 35A	04713	SDA10254-21
U2	1990-0593	1	opto-isolator	04713	SOC-156
U3,4	1906-0006	1	dio-fw brdg 400V 1A	14936	WO4 Special
VR1	1902-3104	1	dio-znr 5.62V \pm 5%	04713	SZ30016-110
VR2	1902-3180	1	dio-znr 11.8V 2%	04713	SZ30016-204

Table 6-4. Replacement Parts (continued)

Ref. Desig.	HP Part No.	TQ	Description	Mfr. Code	Mfr. Part No.
A2			Control Board Assembly		
C1,51,52	0180-0230	3	cap 1 μ F 20% 50V	56289	15D105X0050A2
C2,23	0160-4557	2	cap 0.1 μ F 20% 50V cer	16299	CAC04X7R104M050-A
C3,8,53	0160-0128	3	cap 2.2 μ F 20% 50V	56289	5CZ5U225X0050C5C-CML
C4-6,9, 14,20,21, 25,28-30, 33,36-38	0160-4722	15	cap 0.1 μ F + 80-20% 50V cer	16299	CAC03Z5U104Z050A
C7,57	0140-0203	2	cap 30pF 5% 500V mica	28480	
C10,22	0160-4741	2	cap 0.22 μ F 10% 50V cer	20932	5030EM50RD224M
C11,18	0160-0163	2	cap .033 μ F 10% 200V	56289	192P33392
C12	0160-0159	1	cap 6800pF 10% 200V poly	56289	192P68292
C13	0160-0127	1	cap 1 μ F 20% 25V cer	20932	5033E525RD105M
C15	0180-0218	1	cap 0.15 μ F 10% 35V	56289	150D154X9035A2-DYS
C16	0160-0162	1	cap .022 μ F 10% 200V poly	84411	HEW238M
C17	0160-2036	1	cap 4300pF 5% 500V mica	28480	
C19	0160-0194	1	cap .015 μ F 10% 200V	56289	192P15392
C24,42	0180-0137	2	cap 100 μ F 20% 10V	56289	150D107X0010R2-DYS
C26	0180-1980	1	cap 1 μ F 5% 35V	56289	150D107X5035A2-DYS
C27	0180-0405	1	cap 1.8 μ F 10% 20V	56289	150D185X9020A2
C31,49	0140-0149	2	cap 470pF 5% 300V mica	28480	
C32	0140-0199	1	cap 240pF 5% 300V mica	28480	
C34,35	0160-3070	2	cap 100pF 5% 300V mica	28480	
C39,40	0160-0134	2	cap 220pF 5% 300V mica	28480	
C41	0180-0550	1	cap 330 μ F + 100-10% 25V	54473	ECE-A25V330L
C43,50	0180-0291	2	cap 1 μ F 10% 35V	56289	150D105X9035A2
C44	0140-0200	1	cap 390pF 5% 300V mica	28480	
C45,46	0160-0174	2	cap 0.47 μ F + 80-20% 25V cer	20932	5033ES25RD47RZ
C47	0160-2215	1	cap 750pF 5% 300V mica	28480	
C48,55	0160-2639	2	cap 5000pF 20% 100V cer	72982	835-100-Z5U-502M
C54	0160-2496	1	cap 470pF 10% 1kV	28480	
C56	0140-0210	1	cap 270pF 5% 300V mica	28480	
CR1,3,7, 9,12-15, 17-19,22-30	1901-0050	20	dio-switching	07263	FDH 6308
CR2,4-6, 8,10, 11,16,20,21	1901-0033	10	dio-gen PRP	07263	FDH 3369
J1,2	1200-0507	2	connector, 16 pin	06776	0002811
L1,3	9140-0210	2	coil 100 μ H 5%	28480	
L2	9140-0131	1	coil 10mH 5%	28480	
Q1	1855-0413	1	J-fet P-chan D-mode	28480	
Q2,3,5-7, 9,10	1854-0823	7	xstr NPN si	01295	SKC0221
Q4	1853-0086	1	xstr PNP si 2N5087	27014	2N5087
Q8	1853-0041	1	xstr PNP si	07263	S21297
Q11	1854-0448	1	xstr NPN si	04713	SS1147
Q12	1854-0585	1	xstr NPN si	04713	MJE182
R1,2,4-6, 18,19	0686-1035	7	res 10k 5% 0.5W cc	01121	EB1035
R3,48,51, 74,102,105, 106,129	0683-4725	8	res 4.7k 5% 0.25W cc	01121	CB4725
R7,25	0683-3355	2	res 3.3M 5% 0.25W cc	01121	CB3355

Table 6-4. Replacement Parts (continued)

Ref. Desig.	HP Part No.	TQ	Description	Mfr. Code	Mfr. Part No.
R8	0757-0413	1	res 392 Ω 1% 0.125W f	24546	C4-1/8-TO-61R9
R9	0757-0480	1	res 432k 1% 0.125W f	91637	CMF-55-1,T-1
R10	0757-0344	1	res 1M 1% 0.25W f	19701	MF52C-1
R11,13	0683-1005	2	res 10 Ω 5% 0.25W fc	01121	CB1005
R12,30, 55,124	0757-0280	4	res 1k 1% 0.125W f	24546	C4-1/8-TO-1001-F
R14,41,90	0757-0461	3	res 68.1k 1% 0.125W f	24546	C4-1/8-TO-6812-F
R15	0757-0398	1	res 75 Ω 1% 0.125W	2M627	CRB14
R16	0698-6343	1	res 9k 0.1% 0.125W f	91637	CMF-55-1,T-9
R17	0698-4158	1	res 100k 0.1% 0.125W f	91637	CMF-55-1,T-9
R20,24,130	2100-3273	3	res-trmr 2k 10%	73138	72XR2K
R21,23,131	2100-3353	3	res-trmr 20k 10%	02111	63X203T623
R22	2100-3351	1	res-trmr 500 Ω 10%	02111	63X501T623
R26	0698-7880	1	res 28.7k 1% 0.125W f	24546	C4-1/8-TO-2872-F
R27	0698-6335	1	res 900 Ω 1% 0.125W f	24546	C4-1/8-TO-900R-F
R28,81,83	0757-0451	3	res 24.3k 1% 0.125W f	24546	C4-1/8-TO-2432-F
R29,47,132	0757-0438	3	res 5.11k 1% 0.125W f	24546	C4-1/8-TO-511R-F
R31,45,60	0757-0452	3	res 27.4k 1% 0.125W f	24546	C4-1/8-TO-2742-F
R32	0757-0424	1	res 1.1k 1% 0.125W f	24546	C4-1/8-TO-1101-F
R33,53, 62,91,112	0757-0465	5	res 100k 1% 0.125W f	24546	C4-1/8-TO-1003-F
R34,46	0757-0449	2	res 20k 1% 0.125W f	91637	CCMF-55-1,T-1
R35	0757-0442	1	res 10k 1% 0.125W f	24546	C4-1/8-TO-1002-F
R36,104	0683-1045	2	res 100k 5% 0.25W fc	01121	CB1045
R37,133,134	0757-0467	3	res 121k 1% 0.125W f	24546	C4-1/8-TO-1213-F
R38,95	0683-1065	2	res 10M 5% 0.25W fc	01121	CB1065
R39,64	0683-2035	2	res 20k 5% 0.25W fc	01121	CB2035
R40,156	0698-4484	2	res 19.1k 1% 0.125W f	24546	C4-1/8-TO-1912-F
R42	0698-3455	1	res 261k 1% 0.125W f	24546	C4-1/8-TO-2613-F
R43,107	0683-1055	2	res 1M 5% 0.25W fc	01121	CB1055
R44	0698-5092	1	res 160k 1% 0.125W f	24546	C4-1/8-TO-1603-F
R49,50	0698-6631	2	res 2.5k 0.1% 0.125W f	24546	NE55
R52,148,154	0683-1035	3	res 10k 5% 0.25W fc	01121	CB1035
R54	0698-4536	1	res 340k 1% 0.125W f	24546	NA4
R56,69, 73,75,77, 78,88, 98,103,146	0683-2225	10	res 2.2k 5% 0.25W fc	01121	CB2225
R57	0683-5105	1	res 51 Ω 5% 0.25W fc	2M627	R-25J
R58	0757-0283	1	res 2k 1% 0.125W f	24546	C4-1/8-TO-2001-F
R59,63	0757-0346	2	res 10 Ω 1% 0.125W f	2M627	CRB25
R61,94,122	0683-4715	3	res 470 Ω 5% 0.25W fc	01121	CB4715
R65	0698-4444	1	res 4.87k 1% 0.125W f	24546	C4-1/8-TO-487R-F
R67,68, 72,76,138	0683-2015	5	res 200 Ω 5% 0.25W fc	01121	CB2015
R70,71	0683-5115	2	res 510 Ω 5% 0.25W fc	01121	CB5115
R79,142	0757-0446	2	res 15k 1% 0.125W f	24546	C4-1/8-TO-1502-F
R80	0757-0455	1	res 36.5k 1% 0.125W f	24546	C4-1/8-TO-3562-F
R82	0683-1015	1	res 100 Ω 5% 0.25W fc	01121	CB1015
R84	0698-3498	1	res 8.66k 1% 0.125W f	24546	C4-1/8-TO-866R-F
R85	0757-0199	1	res 21.5k 1% 0.125W f	24546	C4-1/8-TO-2151-F
R86,137	0683-0335	2	res 3.3 Ω 5% 0.25W fc	01121	CB0335

Table 6-4. Replacement Parts (continued)

Ref. Desig.	HP Part No.	TQ	Description	Mfr. Code	Mfr. Part No.
R87,109	0683-5125	2	res 5.1k 5% 0.25W fc	01121	CB5125
R92,100	0683-1025	2	res 1k 5% 0.25W fc	01121	CB1025
R93	0698-5094	1	res 5.1M 5% 0.25W fc	01121	CB5094
R96,116,117	0698-0085	3	res 2.67K 1% 0.125W f	2M627	C4-1-1/8-TO-267R-F
R99	0683-2265	3	res 22M 5% 0.25W fc	01121	CB2265
R101,155, 160	0683-2025	4	res 2k 5% 0.25W fc	01121	CB2025
R108,153	0683-3335	2	res 33k 5% 0.25W fc	01121	CB3335
R110	0698-3136	1	res 17.8k 1% 0.125W f	24546	C4-1/8-TO-1782-F
R111	0757-0483	1	res 562k 1% 0.125W f	24546	C4-1/8-TO-5623-F
R113,123	0683-3925	2	res 3.9k 5% 0.25W	01121	CB3925
R114	0698-3151	1	res 2.87k 1% 0.125W f	91637	CMF-55-1,T-1
R115	0757-0422	1	res 909Ω 1% 0.125W f	24546	C4-1/8-TO-909R-F
R118	0757-0200	1	res 5.62k 1% 0.125W f	24546	C4-1/8-TO-562R-F
R119	0698-5152	1	res 63k 1% 0.125W f	24546	C4-1/8-TO-6302-F
R120,144, 145	0698-0084	3	res 2.15k 1% 0.125W f	24546	C4-1/8-TO-2151-F
R121	0757-0420	1	res 750Ω 1% 0.125W f	24546	C4-1/8-TO-750R-F
R125	0683-2715	1	res 270Ω 5% 0.25W fc	01121	CB2715
R126,157	0757-0440	2	res 7.5k 1% 0.125W f	24546	C4-1/8-TO-7501-F
R127	0698-3558	1	res 4.02k 1% 0.125W f	24546	C4-1/8-TO-402R-F
R128	0757-0427	1	res 1.5k 1% 0.125W f	24546	C4-1/8-TO-1501-F
R135	0757-0410	1	res 301Ω 1% 0.125W f	91637	CMF-55-1,T-1
R136	0698-6889	1	res 22.1k 0.5% 0.125W f	91637	CMF-55-1,T-2
R139	0757-0273	1	res 3.01k 1% 0.125W f	24546	C4-1/8-TO-301R-F
R140	0757-0123	1	res 34.8k 1% 0.125W f	24546	C4-1/8-TO-3482-F
R141	0683-2235	1	res 22k 5% 0.25W fc	01121	CB2235
R143	0698-4470	1	res 6.98k 1% 0.125W f	91637	CMF-55-1,T-1
R147	0698-3496	1	res 3.57k 1% 0.125W f	24546	C4-1/8-TO-357R-F
R149	0698-4435	1	res 2.49k 1% 0.125W f	24546	C4-1/8-TO-249R-F
R150	0698-4196	1	res 1.07k 1% 0.125W f	24546	C4-1/8-TO-107R-F
R151	0698-6938	1	res 196k 0.5% 0.125W f	91637	CMF-55-1,T-2
R152	0757-0473	1	res 221k 1% 0.125W f	91637	CMF-55-1,T-1
R158	0757-0290	1	res 6.19k 1% 0.125W f	24546	C4-1/8-TO-619R-F
R159	0757-0436	1	res 4.32k 1% 0.125W f	24546	C4-1/8-TO-432R-F
R161	0698-3225	1	res 1.43k 1% 0.125W f	24546	C4-1/8-TO-143R-F
R163	0757-0472	1	res 200k 1% 0.125W f	24546	C4-1/8-TO-2003-F
TB1	0360-2009	1	Term Block, 10 Term	28480	
U1,19	1826-0346	2	IC Op Amp Dual	27014	LM358N
U2	1826-0493	1	IC Op Amp Dual	04713	SC73140P
U3	1820-0477	1	IC Op Amp	27014	LM301AN
U4,6	1826-0161	2	IC 324 Op Amp, Quad	27014	LM324N
U5,14	1826-0065	2	IC Comparator	27014	LM311N
U7	1820-1272	1	IC Quad Buffer	01295	SN74LS33N
U8	1820-1209	1	IC 2-IN NAND, Quad	01295	SN74LS38N
U9	1820-1112	1	IC D-Type FF	27014	SN74LS574N
U10	1820-1203	1	IC 3-In AND, Triple	01295	SN74LS11N
U11	1820-1443	1	IC Counter, TTL	04713	SN74LS293N
U12	1820-1437	1	IC Multivibrator, Dual	01295	SN74LS221N
U13	1826-0138	1	IC Comparator, Quad	04713	MLM339P
U15	1820-0430	1	IC Voltage Reg	27014	LM309K
U16	1858-0023	1	xstr array NPN si	3L585	CA3081E
U17,18	1820-0493	2	IC op amp	27014	LM307N

Table 6-4. Replacement Parts (continued)

Ref. Desig.	HP Part No.	TQ	Description	Mfr. Code	Mfr. Part No.
VR1	1902-0057	1	dio-znr 6.49V 5%	12954	DZ730821C
VR2,4	1902-0575	2	dio-znr 6.5V 2%	12954	SZ11594
VR3	1902-0766	1	dio-znr 18.2V 5%	04713	SZ30016-257
VR5	1902-3092	1	dio-znr 4.99V 2%	12954	DZ730818Z
VR6	1902-0777	1	dio-znr 6.2V 5%	04713	1N825
VR7	1902-3002	1	dio-znr 2.37V 5%	04713	SZ10939-2
Y1	0960-0586	1	resonator-ceramic	28480	
A3			FET Assembly, 2 Units		
C1	0160-4569	1	cap 0.01 μ F 10% 800Vdc	56289	715P10398LD3
C2	0180-0374	1	cap 10 μ F 10% 20V	56289	150D106X9020B2-DYS
C3	0180-0155	1	cap 2.2 μ F 20% 20V	56289	150D225X0020A2
CR1	1901-1087	1	dio-pwr rect 600V 3A	04713	MR856
CR2-4	1901-0050	3	dio-switching	07263	FDH 6308
L1	9100-1618	1	coil 5.6 μ H 10%	28480	
Q1,2*	5080-1926	2	FET-dual T03	28480	
Q3	1854-0585	1	xstr NPN si	04713	MJE182
R1	0811-1906	1	res 150 Ω 5% 10W pw	91637	RS-10
R2	0811-1065	1	res 150 Ω 5% 10W pw	01686	NT-10-78
R3-6	0698-3609	4	res 22 Ω 5% 2W	27167	Fp-42
R7	0683-0275	1	res 2.7 Ω 5% 0.25W fc	01121	CB0275
R8	0683-1815	1	res 180 Ω 5% 0.25W fc	01121	CB1815
R9	0683-2745	1	res 270k 5% 0.25W fc	01121	CB2745
R10	0683-1505	1	res 15 Ω 5% 0.25W fc	01121	CCB1505
R11	0683-0335	1	res 3.3 Ω 5% 0.25W fc	01121	CB33G5
R12,13	0683-8205	2	res 82 Ω 5% 0.25W fc	01121	CB8205
R14-16	0698-3547	3	res 1 Ω 5% 0.5W cc	01121	EB3547
T1	06012-80091	1	xfrm-pulse	28480	
TS1	3103-0081	1	sw-therm	14604	2455R-87-247
U1,2	1820-1050	2	IC dual 2-IN NOR, ttl	01295	SN75454BP
VR1	1902-3092	1	dio-znr 4.99V 2%	12954	DZ730818Z
A4			Output Diode Board		
C1	0160-4569	1	cap .01 μ F 10% 800Vdc	56289	715P10398LD3
CR1	1901-0887	1	dio-pwr rect 50A	28480	
L1	9170-0707	2	choke assy, consists of: core-ferrite	28480	
	06012-80003	1	wire-snobber	28480	
Q1	1854-0755	1	xstr NPN si	3L585	2N6254
R1	0812-0019	1	res .33 Ω 5% 3W pw	91637	CW-2B-39
R2	0683-1025	1	res 1k 5% .25W fc	01121	CB1025
R3	0811-1068	1	res 50 Ω 5% 10W pw	01686	NT10-78
TS1	3103-0082	1	sw-therm	14604	2450-87-246
A5			Front Panel Assembly		
DS1,2,5	1990-0521	3	LED Green	28480	
DS3,4,6	1990-0517	3	LED Red	28480	
M1	1120-1392	1	Meter-Volts	28480	
M2	1120-1393	1	Meter-Amperes	28480	
R1	0683-2015	1	res 200 Ω 5% 0.25W fc	01121	CB2015
R2,3	2100-3831	2	res-var 2.7k 5% 0.5W	32997	83A1D-1324-BA0380
R4	2100-3252	1	res-var 5k 10%	01121	E2A502

* Should be replaced in pairs.

Table 6-4. Replacement Parts (continued)

Ref. Desig.	HP Part No.	TQ	Description	Mfr. Code	Mfr. Part No.
A6			AC Filter Assembly		
C18,19	0160-4355	2	cap .01 μ F 10% 250Vac	C0633	PME271Y510
C20	0160-4962	1	cap 1.0 μ F 20% 250Vac	†	MKS4-R/1.0/250/20%
CB1	3105-0126	1	circuit breaker 25A 250Vac	28480	
R22	0686-8245	1	res 820k 5% 0.5W cc	01121	EB8245
TB1	0360-1214	1	term block, 3-term	28480	
			Chassis Electrical Parts		
B1	3160-0328		fan-tubeaxial 115V	4N833	125XR-2182
C21	0180-3049	1	cap 2600 μ F -10 + 50% 75Vdc	00853	101262T075AJ2A
L6	06012-80098	1	choke-line	28480	
L7	06012-80094	1	choke-RFI	28480	
S1	3101-0447	1	sw-DPDT	31918	1XFA01-0003-06 (none) N302UTV5EE
A1			Main Board-Mechanical		
	2110-0269	2	fuseholder, clip type (F1)	28480	
	0380-1265	2	spacer, press in (K1)	28480	
	1200-0181	1	spacer, plastic (Q2)	28480	
	0360-1750	4	contact-terminal, single (CR3,CR4)	28480	
	0360-1843	12	terminal-stud (R1,2,3,5,6,13)	28480	
	0362-0669	2	contact-terminal, single (W1)	28480	
	1205-0397	1	heat sink (U1)	28480	
	1251-0600	4	contact-terminal, single (W2,J5,J6)	28480	
A2			Control Board-Mechanical		
	0340-0166	1	insulator bushing (Q1)	28480	
	1200-0181	2	spacer, plastic (Q8,Q11)	28480	
	1205-0267	1	heat sink (U15)	28480	
	0340-0503	1	insulator (U15)	28480	
A3			FET Assembly (each)-Mechanical		
	06012-20001	1	heat sink (Q1,Q2)	28480	
	0340-0166	4	insulator bushing(Q1,Q2)	28480	
	1251-5318	4	contact-connector, single (Q1,Q2)	28480	
	0360-1843	4	terminal-stud (R1,R2)	28480	
	1390-0513	2	fastener-plastic (cover)	28480	
A4			Output Diode Board-Mechanical		
	06012-20002	1	heat sink (CR1,Q1)	28480	
	0340-0166	2	insulator bushing (Q1)	28480	
	1251-5318	2	contact-connector (Q1)	28480	
	0360-1843	2	terminal-stud (R3)	28480	
	1390-0513	2	fastener-plastic (cover)	28480	
A5			Front Panel Assembly-Mechanical		
	0340-0447	6	insulator (DS1-6)	28480	
	5060-2807	1	cable assembly	28480	

Table 6-4. Replacement Parts (continued)

Ref. Desig.	HP Part No.	TQ	Description	Mfr. Code	Mfr. Part No.
			Chassis-Mechanical		
	06012-00004	1	chassis and rear panel	28480	
	06012-00006	1	top cover	28480	
	06012-00007	1	bottom cover	28480	
	5040-7201	4	foot	28480	
	06012-00002	1	front panel	28480	
	5020-8803	1	frame, front	28480	
	5040-7202	1	trim strip, top	28480	
	5060-9803	2	handle assembly	28480	
	5001-0439	2	trim, side, vinyl	28480	
	5040-7234	4	handle trim, plastic	28480	
	06012-00012	1	bracket-meter	28480	
	06012-00003	1	bracket-fan	28480	
	06012-00009	1	bracket-capacitor	28480	
	1390-0514	4	fastener-plastic, snap in (bus bars)	28480	
	06012-00011	2	bus bar	28480	
	4040-1686	1	cover, output bus	28480	
	06012-00010	1	heat sink cover	28480	
	06012-00005	1	panel, ac filter assembly	28480	
	0100-0300	1	cable clamp, strain relief, line cord	28480	
	06024-00011	1	cover, option 002 access hole	28480	
			Miscellaneous		
	0360-0523	4	jumper, terminal block	28480	
	9211-3487	1	packing carton	28480	
	9220-1401	2	packing floater pad	28480	
	9220-3390	4	packing carton filler	28480	

SECTION VII

COMPONENT LOCATION ILLUSTRATIONS AND CIRCUIT DIAGRAMS

7-1 This section contains component location diagrams, a schematic diagram, and other drawings and tables useful for maintenance of the 6012A power supply. (Illustrations for Option 002 are given in Appendix A.) Included in this section are:

a. Top view of unit with covers removed. (Figure 7-1), showing sub-assembly locations, chassis-mounted components, main board mounting screws, troubleshooting test points, and wire colors.

b. Component location diagrams (Figure 7-2 through 7-6), showing the physical location and reference designators of almost all electrical parts. (Front-panel-mounted components are identified by lettering on the board and front panel.)

c. Test point description table (Table 7-1), listing the signals at the 26-pin edge connector (P2) and the 16-pin option-002 jack (J1) at the top of the A2 Control Board.

d. Bias supplies table (Table 7-2), listing the semiconductor components operating on each bias supply.

e. Logic symbols diagram (Figure 7-7), illustrating the logic symbols used on the schematic.

f. Power supply waveforms (Figure 7-8), illustrating waveforms found at key points in the power supply.

g. Schematic diagram (Figure 7-9), including case outline drawings for each of the semiconductor components used in the power supply. The test points shown on the schematic are described in Table 7-1.

WARNING

Wait two minutes after turning power off for input capacitors to discharge before performing any maintenance procedures. To avoid excessive in-rush current, do not operate relay manually.

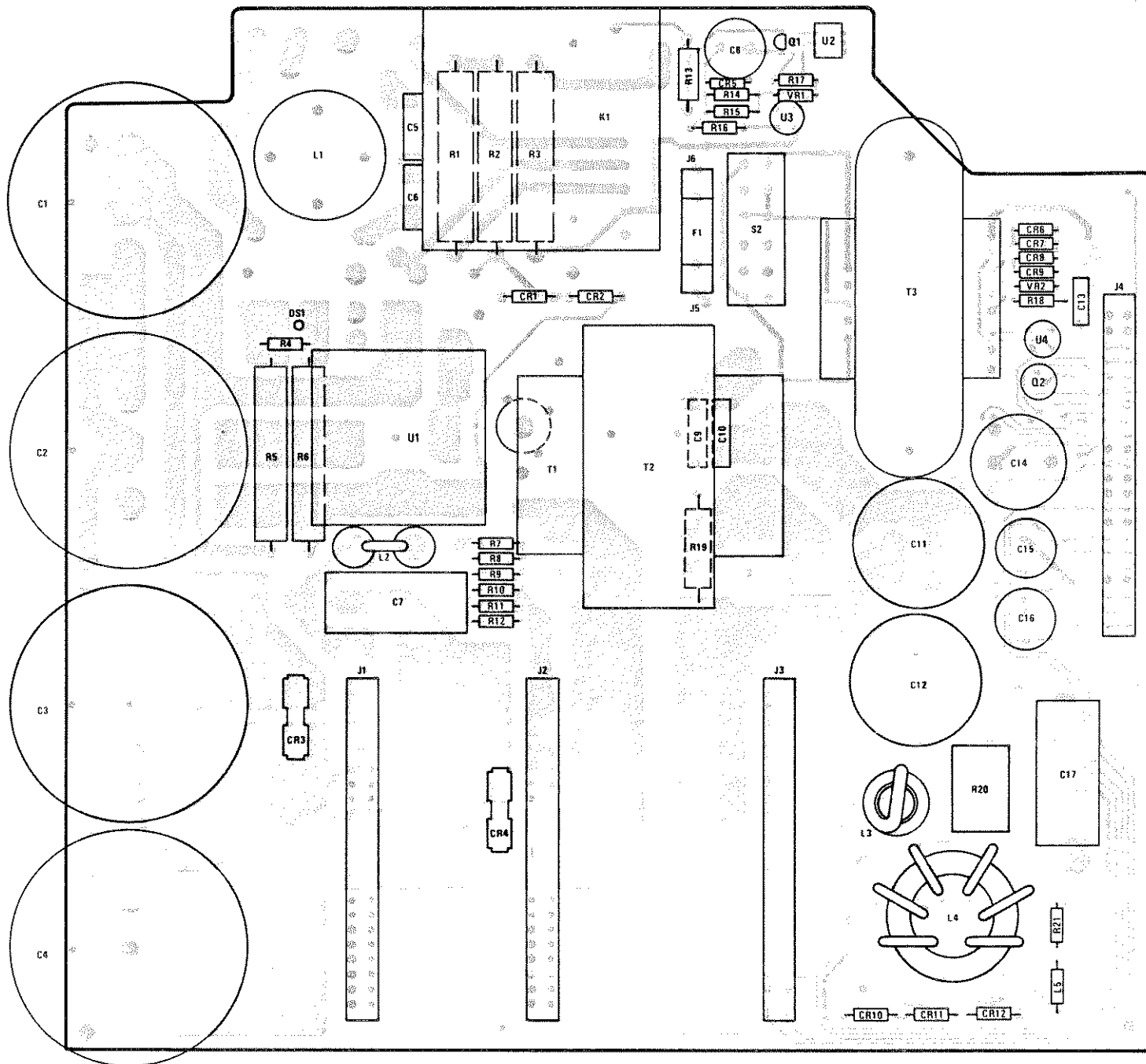

Figure 7-2. Main Board (A1) Component Location.

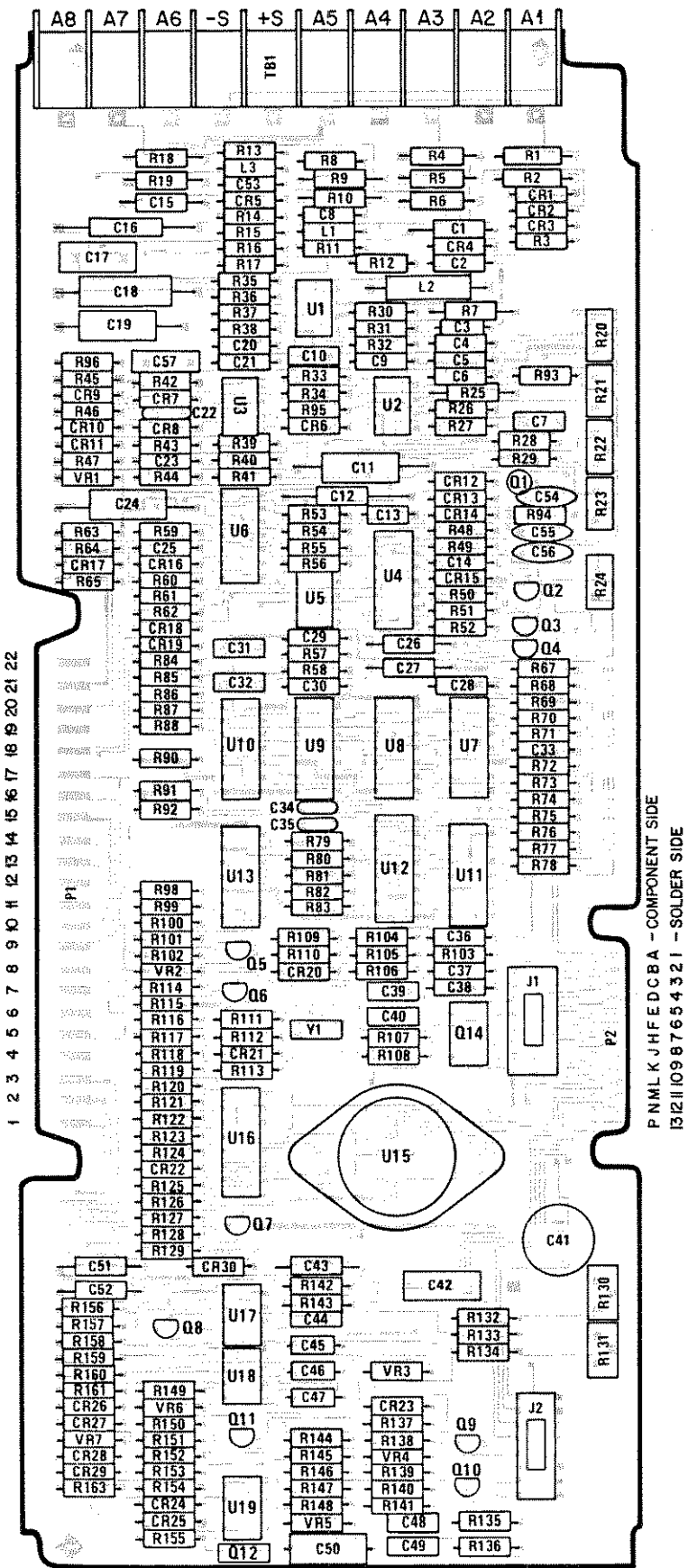

Figure 7-3. Control Board (A2) Component Location

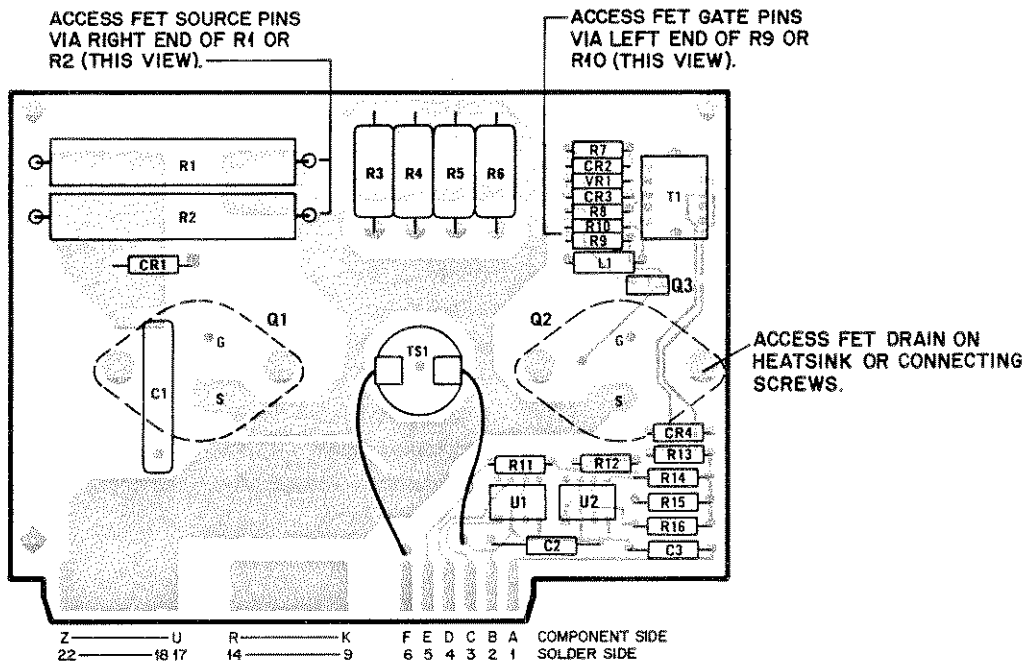

Figure 7-4. FET Board (A3) Component Location

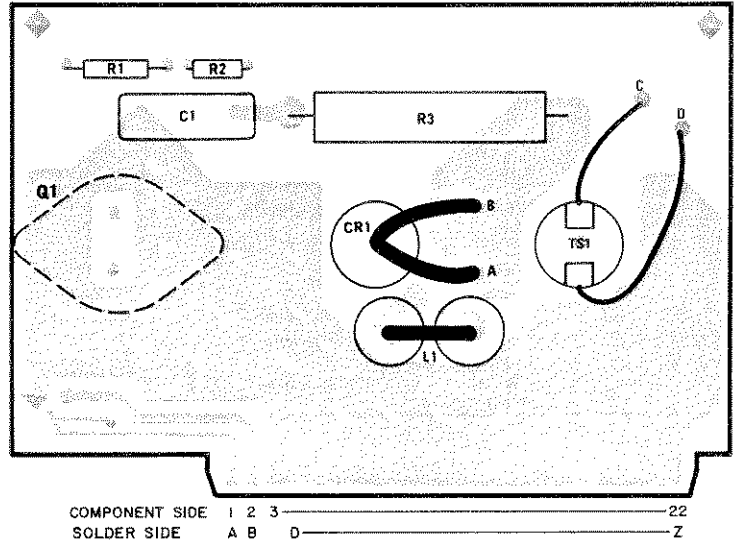

Figure 7-5. Output Diode Board (A4) Component Location

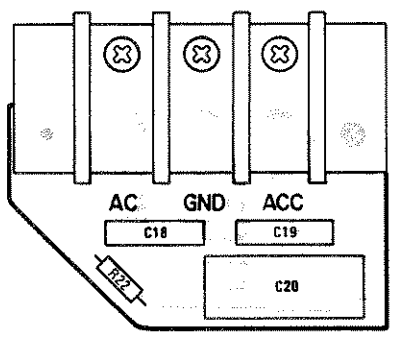

Figure 7-6. AC Filter Assembly Component Location

Table 7-1. Test Point Descriptions

Test Point Connector P2 Pin No.	Option 002 Connector J1 Pin No.	Description
A	—	CV Amplifier Output
1	—	CC Amplifier Output
B	9	Constant Voltage Mode (Low = CV)
2	8	–12 V Unregulated (≈ -25 V)
C	10	OVP Remote Reset Input (low = reset)
3	7	CC Programming Input
D	11	+15V Unregulated ($\approx +25$ V)
4	6	CV Programming Input
E	12	Bias Power Supplies Common
5	5	+ Sense
F	13	Primary Power Fault (low = low level or ac dropout)
6	4	Outboard Sense (common)
H	14	Overtemperature Status (low = overtemperature)
7	3	I-Monitor Buffer Amplifier Output
J	15	Constant Current Mode (low = CC)
8	2	– Sense
K	16	+5 V Unregulated ($\approx +16$ V)
9	1	Overshoot Status (low = OVP)
L	—	On Pulses
10	—	Off Pulses
M	—	+5 V Regulated
11	—	20 kHz Clock Signal
N	—	(not used)
12	—	+ 15 V Regulated
P	—	– 12 V Regulated
13	—	I_p (Primary Current) Ramp Voltage





Table 7-2. Semiconductor Components Operating On Each Bias Supply

+5 V REG	+15V REG	– 12 V REG
A1U2	A2Q1	A2U1
A2Q2	A2Q4	A2U2
A2Q3	A2Q7	A2U3
A2Q5	A2Q9 (+ 6.5V)	A2U4
A2Q6	A2U1	A2U5
A2Q10	A2U2	A2U6
A2U5	A2U3	
A2U7	A2U4	– 12 V UNREG
A2U8	A2U6	A2Q8
A2U9	A2U19 (+ 14.5 V)	A2U17
A2U10		
A2U11	+ 15 V UNREG	+ 5 V UNREG
A2U12	A2Q11	A2U15
A2U13	A2U18	
A2U14		
A2U16		
A3U1		
A3U2		

Definitions

High = more positive
 Low = less positive

Indicator And Qualifier Symbols

-  (polarity indicator, shown outside logic symbol) Any marked input or output is active low; any unmarked input or output is active high.
-  (dynamic indicator) Any marked input is edge-triggered, ie, active during transition between states; any unmarked input is level sensitive.
-  open-collector output
-  monostable (one-shot) multivibrator
- $t=x\text{Sec}$ indicates pulse width (usually determined by external RC network)
- G gate input (a number following G indicates which inputs are gated)
- C control input (clock)
- R reset (clear)
- S set

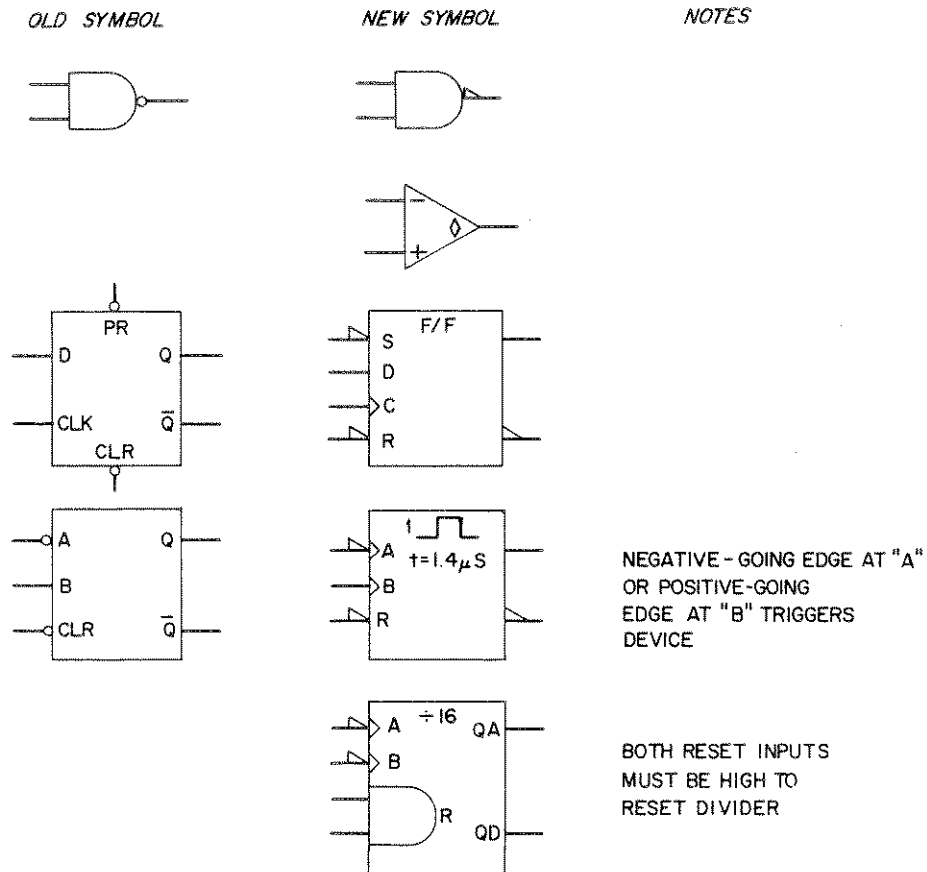

Figure 7-7. Logic Symbols and Definitions

NOTES:

1. Waveforms 1,2,3, and 4 are taken with 6012A operating at nominal line voltage.
2. Waveforms 5,6,7, and 8 are taken with test setup shown in Figure 5-10; i.e., fuse A1F1 removed, bias supplies operating at nominal line voltage, and input bus voltage controlled by an external dc power supply.
3. Except for waveforms 5,6, and 7, oscilloscope probe is grounded at A2U15 case.
4. For waveform 5, oscilloscope probe is grounded at source pin.
5. For waveforms 6 and 7, oscilloscope probe is grounded at whichever pin, drain or source, is connected to the input bus. For FET assembly to left of instrument as viewed from front (upper FET assembly on schematic), probe is grounded at drain (which is connected to + side of input bus). For FET assembly to right of instrument (lower FET assembly on schematic), probe is grounded at source (which is connected to - side of input bus).

WARNING

Procedures described herein are performed with power supplied to the instrument and protective covers removed. Such maintenance should be performed only by service-trained personnel who are aware of the hazards involved (for example, fire and electrical shock). Where procedure can be performed without power applied, power should be removed. Turn power off while connecting or disconnecting test equipment from 6012A.

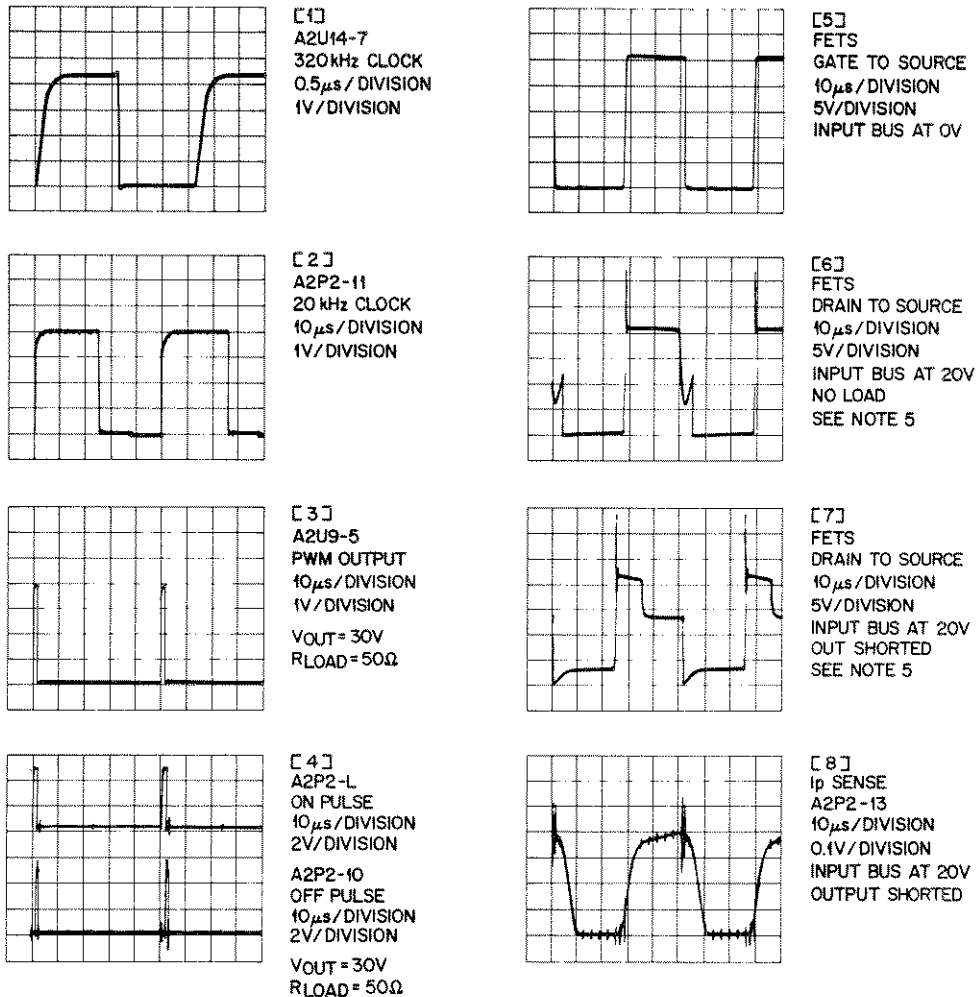

Figure 7-8. Waveforms

APPENDIX A

System Option 002

A-1 GENERAL INFORMATION

A-2 This option facilitates the operation of a 6012A power supply in an automated system. Four major circuit blocks provide: 1) remote analog programming of the supply's output by three different control methods; 2) signals indicating the power supply modes and conditions; 3) two different digital methods of remote control; and 4) the outputs of three bias supplies for use with external circuitry.

A-3 A 6012A power supply equipped with this option can be operated from a 6940B Multiprogrammer equipped with a 69520A Power Supply Programming Card. Details are provided in the 69520A Manual.

A-4 Remote Programming. Through this interface both the output voltage and current can be remotely programmed by either an external voltage source, a resistance, or a current sink.

A-5 Status Indicators. Six optically isolated lines provide open-collector digital outputs which indicate the following states: constant voltage mode, constant current mode, output unregulated, AC fault, overvoltage, and overtemperature.

A-6 Remote Control. Two optically isolated methods of remote control are available. One method requires a negative-going edge, which sets a latch on the 002 card to inhibit the power supply. The latch and the power supply OVP are reset by a negative-going pulse on another input line. The second

method of remote control requires a low logic level to inhibit the power supply for the duration of the low level.

A-7 Bias Supplies. The outputs of three bias supplies are also available at the option connector. These outputs are; +15 V, -15 V, and +5 V.

A-8 Monitoring of the output voltage and current of the power supply is also possible at the option connector.

A-9 Other modes of operation, such as multiple supply system control, are described in detail in later paragraphs. Modes such as Auto-Series, Auto-Parallel, and Auto-Tracking operation, as described in Section 3 of the main text are also available.

A-10 Specifications

A-11 Table A-1 provides specifications for the Option 002. This table is referred to periodically throughout the Operation section of this Appendix.

A-12 Option 002 Hardware

A-13 The option 002 hardware consists of a single printed-circuit board installed at the right of the 6012A chassis. A cable connects the option board to the A2 control board at A2J1. Connections between the option board and external circuits are made via a 37-pin connector mounted on the option board and available at the rear of the power supply. A mating connector is also included for the user's convenience.

Table A-1. Specifications, Option 002

<p>All 6012A specifications remain the same unless otherwise noted. All specifications are at option board connector J2.</p> <p>REMOTE PROGRAMMING: Resistance Programming - 0 to 2.5 k Ω provides zero to maximum rated voltage or current output. Accuracy @ 25°C: CV; 1.0% +30 mV CC; 2.5% +35 mA</p> <p>Voltage Programming - 0 to 5 V provides zero to maximum rated voltage or current output. Accuracy @ 25°C: CV; 0.3% +3 mV CC; 1.0% +15 mA</p> <p>Current Programming - 0 to 2 mA current sink provides zero to maximum rated voltage or current output. Accuracy @ 25°C: CV; 0.4% +9 mV CC; 1.1% +20 mA Input Compliance Voltage: ± 1 V</p>	<p>Current Programming Enable - Relays K2 (CV) and K1 (CC) are biased from the CONTROL ISOLATOR BIAS input (see Remote Shutdown and OVP Clear).</p> <table style="width: 100%; border: none;"> <tr> <td style="padding-right: 20px;">Relay bias voltage;</td> <td>+4 V minimum</td> </tr> <tr> <td></td> <td>+7 V maximum</td> </tr> <tr> <td>Relay resistance;</td> <td>500Ω \pm 10%</td> </tr> </table> <p>Note: For CONTROL ISOLATOR BIAS voltages greater than 7 V, a series resistor must be used to maintain the relay bias voltage within specified limits.</p> <p>Enabling either relay is accomplished by bringing CV or CC enable line to CONTROL ISOLATOR BIAS common via a suitable driver; maximum driver off-state leakage = 0.5 mA.</p>	Relay bias voltage;	+4 V minimum		+7 V maximum	Relay resistance;	500 Ω \pm 10%
Relay bias voltage;	+4 V minimum						
	+7 V maximum						
Relay resistance;	500 Ω \pm 10%						

Table A-1. Specifications, Option 002 (cont.)

OUTPUT VOLTAGE MONITOR: 0 to 5 V output indicates zero to maximum rated output voltage.
 Accuracy @ 25°C; 0.2% + 1 mV
 Output Impedance; 8.3 kΩ
 Temperature Coefficient; 0.01% / °C

STATUS INDICATORS:

STATUS ISOLATOR BIAS input (referred to STATUS ISOLATOR COMMON);

Voltage range; +4.75 V to +16 V
 Current Drain; 20 mA maximum

Status Indicator outputs;
 Open-collector outputs
 Maximum output voltage (logic high); +16 V
 Logic low output; +0.4 V maximum at 8 mA

REMOTE CONTROL (TRIP, RESET, INHIBIT)

CONTROL ISOLATOR BIAS input;

Voltage range; +4.75 V to +16 V

Remote control inputs (REMOTE TRIP, REMOTE RESET, REMOTE INHIBIT);

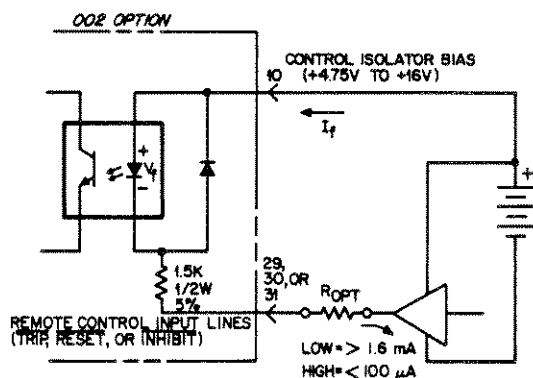

On state (logic low); Minimum forward current required (I_F):
 1.6 mA

Isolator forward voltage (V_F) at 1.6 mA
 I_F : 1.4 V typical, 1.75 V maximum

For CONTROL ISOLATOR BIAS voltage greater than +5 V, an optional resistor (R_{OPT}) may be added to reduce drive current.

Off state (logic high) maximum leakage current; 100 μA

REMOTE TRIP and REMOTE RESET timing;

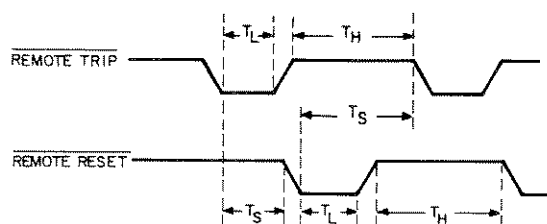

Pulse duration (T_L): 15 μs minimum
 Reset time (T_H): 125 μs minimum
 Set-up time (T_S): 25 μs minimum
 OVP Clear delay (to 6012A mainframe); 1 sec. ± 30%

POWER-ON PRESET:

Output ratings;
 Open collector output (referred to power supply common)
 Maximum output voltage (logic high); +16 V
 Logic low output; +0.4 V maximum at 8 mA
 POWER-ON PRESET pulse timing;

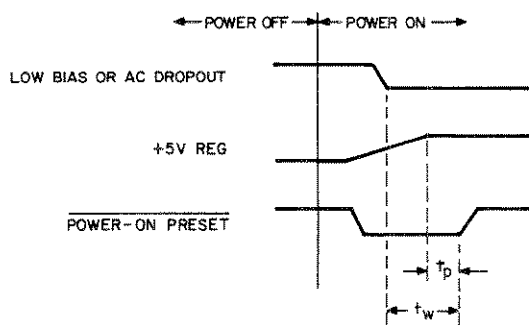

Wait time after LOW BIAS OR AC DROPOUT indication (T_W): 750 ms maximum

Pulse duration after +5 V REG has stabilized (T_p): 10 ms minimum

BIAS SUPPLIES:

DC output ratings (0 to 55°C);

+ 5 V ± 1.3% at 100 mA
 + 15 V ± 1.5% at 75 mA
 - 15 V ± 2.5% at 75 mA

Short circuit output current;

+ 5 V - 170 mA ± 15%
 + 15 V - 125 mA ± 15%
 - 15 V - 125 mA ± 20%

Load and Source Effect; Change in output voltage for a load change equal to the maximum available current rating of the supply plus any line voltage change within rating;

+ 5 V - 2.5%
 + 15 V - 3.0%
 - 15 V - 1.0%
 PARD (typical);

+ 5 V - 2 mV RMS
 + 15 V - 3 mV RMS
 - 15 V - 3 mV RMS

ISOLATION:

Status Indicator lines and Remote Control lines may be floated a maximum of 600 VDC from ground, from the power supply output or from each other. These lines may not be connected to any primary circuits.

A-14 INSTALLATION

A-15 The 002 option board can be installed in a 6012A power supply by the user. Proceed as follows:

- a. Turn off power supply and disconnect line cord.
- b. Remove three screws that secure top cover to instrument. Slide cover to rear and lift off.
- c. Disconnect front-panel cable from J2 on A2 control board, remove two screws that secure control board to side panel, and remove control board from 6012A.
- d. Remove and save two screws that secure cover over J2-connector hole in rear panel. Discard J2-connector-hole cover.
- e. Option board is installed on far right side of instrument (as viewed from front). Three tabs on bottom of option board fit into three slots in bottom chassis. Secure option board to side panel with two screws provided.
- f. Using two screws removed in step d, secure option connector (J2) to rear panel.
- g. Reinstall control board in unit and secure to side panel. Reconnect front-panel cable to J2 on control board.
- h. Connect 16-pin ribbon connector (P1) from option board to connector J1 on control board. Red stripe on ribbon cable should be toward end of J1 marked with white dot (toward front of instrument).
- i. Replace top cover.
- j. Read operation section of this appendix before turning on instrument and checking the 002 Option. No preliminary adjustments are required.

A-16 Connector Assembly Procedure

A-17 The following instructions describe assembly of the mating connector provided to interface the user's system with the option connector, J2. Figure A-1 identifies the parts of the mating connector. Proceed as follows:

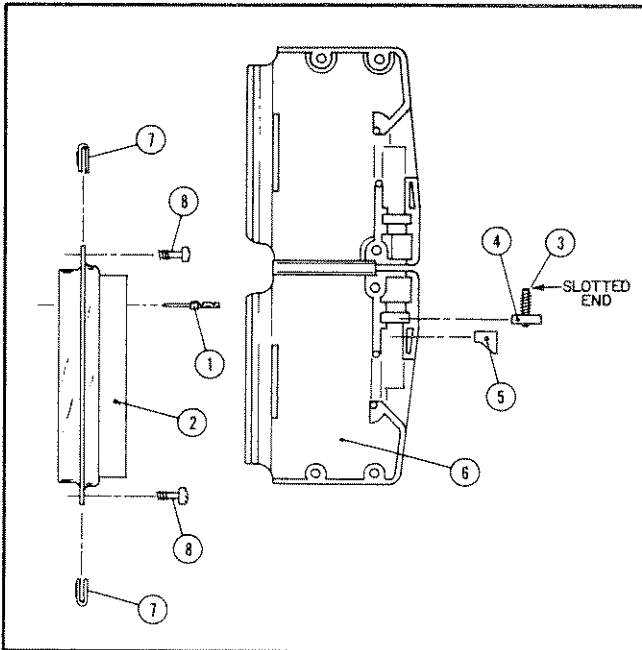

Figure A-1. Mating Connector Assembly

NOTE

It may be desirable to set up a test interface before final assembly of the mating connector to allow checkout of the system. A mating connector with pins accessible for temporary wiring is available from Hewlett-Packard, HP part number 1251-4464.

- a. If a multi-wire cable is being used (as opposed to individual wires), remove approximately 1-½ inches of cable insulation from the end. Be careful not to cut the insulation on the individual wires.
- b. Strip 3/16 inch of insulation from end of each wire to be used.
- c. Insert each wire into a contact pin (1) and crimp firmly.
- d. Insert each pin into proper hole in connector - pin house (2) from rear. Pins will lock into housing when fully inserted.

NOTE

Once the pins are locked into the connector-pin housing, they are extremely difficult to remove. Therefore, be certain pin is in proper hole before inserting fully.

- e. Screw a slotted set-screw (3) partially into a square nut (4) and place in position in connector shield assembly (6).
- f. Place strain relief (5) in position in connector shield assembly (6), just under set screw (3). Be certain that strain relief is oriented as shown in Figure A-1.
- g. Place connector pin housing (2) in shield assembly (6) and route cable through cable entrance.
- h. Fold connector shield assembly (6) and secure with three screws.
- i. Strain relief set screw (3) can now be adjusted from top of connector to clamp firmly on cable.
- j. Clip fasteners (7) onto ends of connector pin housing (2).
- k. Connector can now be plugged onto option connector J2 and secured with two screws (8) into the threaded stand-offs on either side of J2.

A-18 OPERATION

A-19 The following paragraphs provide the operating instructions necessary to interface an 002-equipped power supply into an automated system. A brief description of the circuits is also provided. All connections are made at the 37-pin rear panel connector, J2 (Figure A-2) and can be wired directly into the mating connector supplied for this purpose.

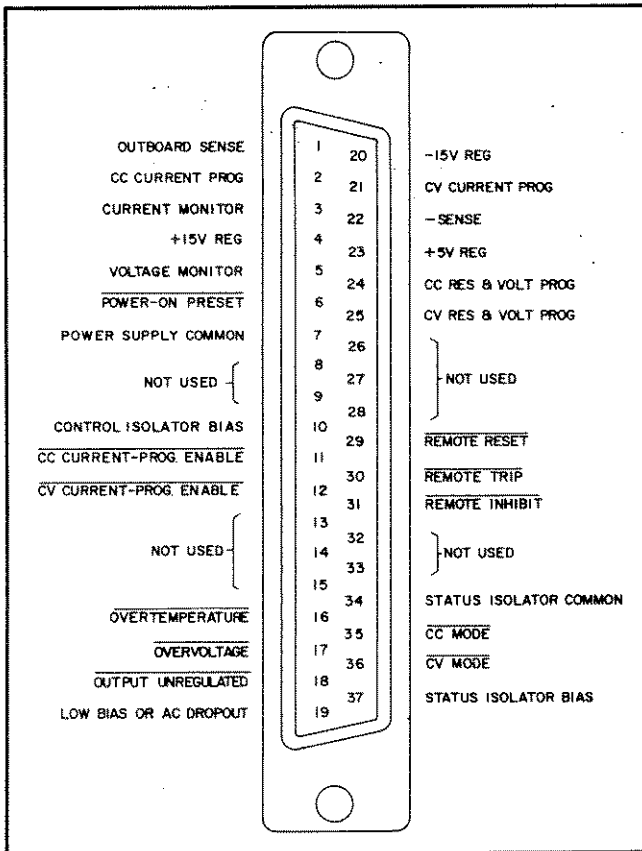

Figure A-2. Rear-Panel Connector J2

A-20 Remote Programming

A-21 Resistance Control (Figure A-3). It is necessary to disable the front panel voltage and current controls during resistance programming. This is accomplished at the rear panel terminal strip by disconnecting the jumper between A4 and A3 (CURRENT control) and the jumper between A8 and A7 (VOLTAGE control).

A-22 A resistance, variable from 0 to 2500 ohms, can be used to program the output voltage or current from 0 to full scale. To program voltage, the variable resistance should be connected from J2-25 (CV RES & VOLT PROG) to J2-22 (- Sense). To program current, the variable resistance should be connected from J2-24 (CC RES & VOLT PROG) to J2-1 (outboard sense). For setting upper and lower limits, refer to paragraphs 3-51 and 3-57.

CAUTION

If the programming lines become open circuited during resistance programming (user's system becomes disconnected from J2), the power supply's output will tend to rise above rating. The supply will not be damaged if this occurs, but the user's load may be damaged. To protect the load, be sure that the overvoltage trip point is properly adjusted and that the CAUTION of paragraph 3-57 is observed.

A-23 Voltage Control (Figure A-4). To program the sup-

ply with a voltage source, it is necessary to disable the front panel control pots and disconnect the supply's internal current sources from the programming voltage nodes. This is accomplished at the rear panel terminal strip by disconnecting the jumpers between A8, A7, and A6 for CV, and the jumpers between A4, A3, and A2 for CC.

A-24 A voltage source, variable from 0 to 5 volts, can be used to program the output voltage or current from 0 to full scale. The load on the programming voltage source is less than 5 μ A. To program voltage, the voltage source should be connected from J2-25 (CV RES & VOLT PROG) to J2-22 (- Sense). To program current, the voltage source should be connected from J2-24 (CC RES & VOLT PROG) to J2-1 (outboard sense). The - output can be up to 1/2 volt positive with respect to outboard sense, and - sense can be up to 1/2 volt positive with respect to - output. Therefore, a potential of up to 1 volt can exist between - sense and outboard sense. A discussion on programming with a voltage greater than 5 volts can be found in paragraphs 3-54 to 3-55.

A-25 If the programming lines become open circuited (user's system become disconnected from J2) during voltage programming, the Programming Protection circuit will reduce the power supply output to zero.

A-26 Current Control (Figure A-5). A current sink, variable from 0 to 2 mA, can be used to program the output voltage or current from 0 to full scale. The following paragraphs provide the necessary instructions for programming with a current sink.

A-27 It is necessary to disable the front panel control pots and disconnect the supply's internal current sources from the programming voltage nodes. This is accomplished at the rear panel terminal strip by disconnecting the jumpers between A8, A7, and A6 for CV, and the jumpers between A4, A3, and A2 for CC.

A-28 Current programming is enabled by relays K2 (for CV) and/or K1 (for CC), which are powered from the CONTROL ISOLATOR BIAS connected to J2-10. Maintaining a low logic level (CONTROL ISOLATOR BIAS supply common) at one or both of the CURRENT PROG. ENABLE inputs, J2-12 (CV) and J2-11 (CC), closes the appropriate relay.

CAUTION

Although CONTROL ISOLATOR BIAS can be +4.75 V to +16 V, a supply voltage of more than 7 V may damage the relays. Therefore, if CONTROL ISOLATOR BIAS exceeds 7 V, it is necessary to use a resistor in series with each of the relay enable lines. Figure A-6 provides a graph and formulas for calculating the proper series resistance value based on the CONTROL ISOLATOR BIAS being used. Be certain to account for the resistor tolerance and CONTROL ISOLATOR BIAS power supply tolerance. The formulas and graph in Figure A-6 account for relay tolerance. Any driver gate voltage drop should be subtracted from the CONTROL ISOLATOR BIAS before using formulas and graph in Figure A-6.

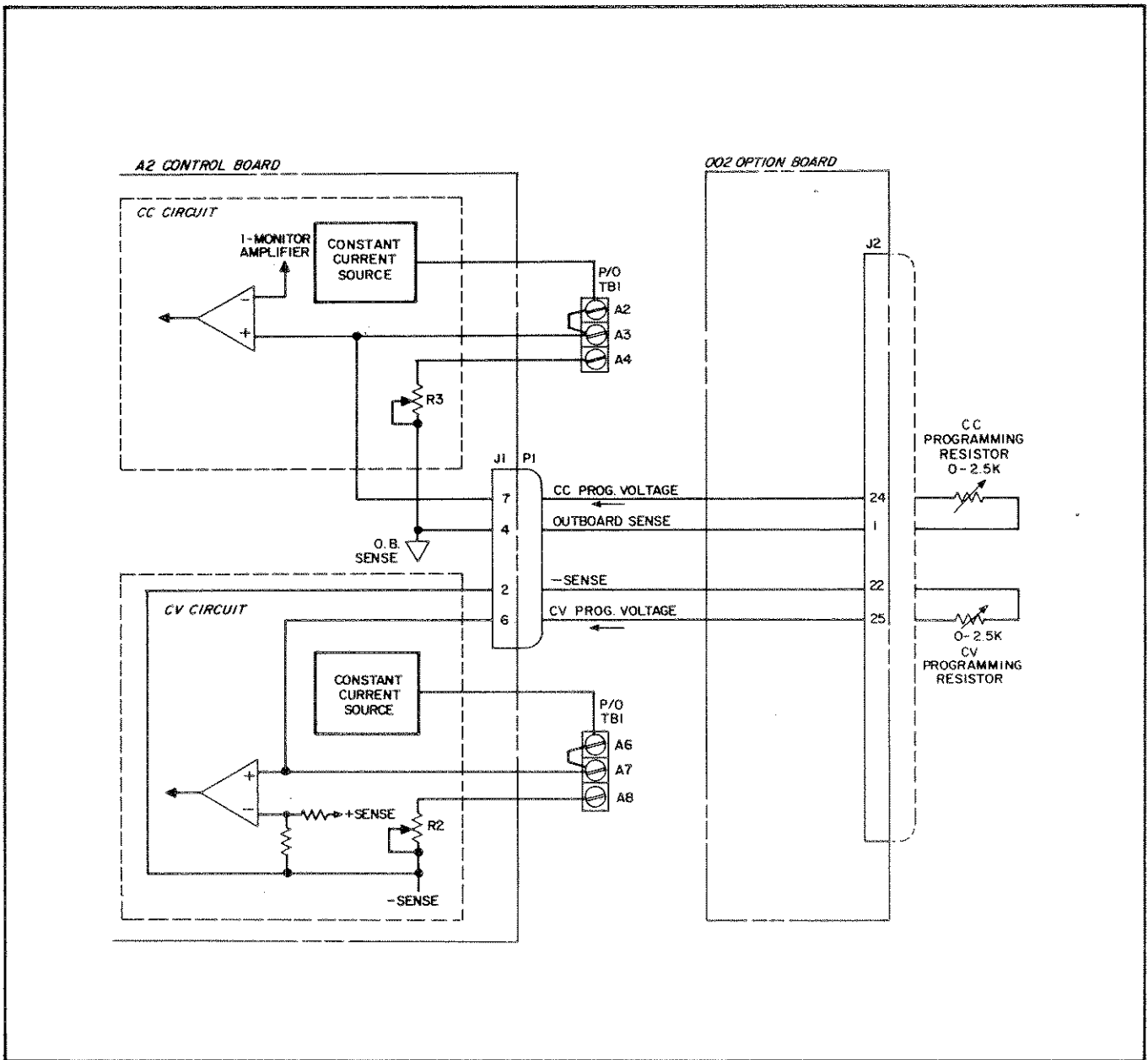

Figure A-3. Resistance Programming of Output Voltage And/Or Current

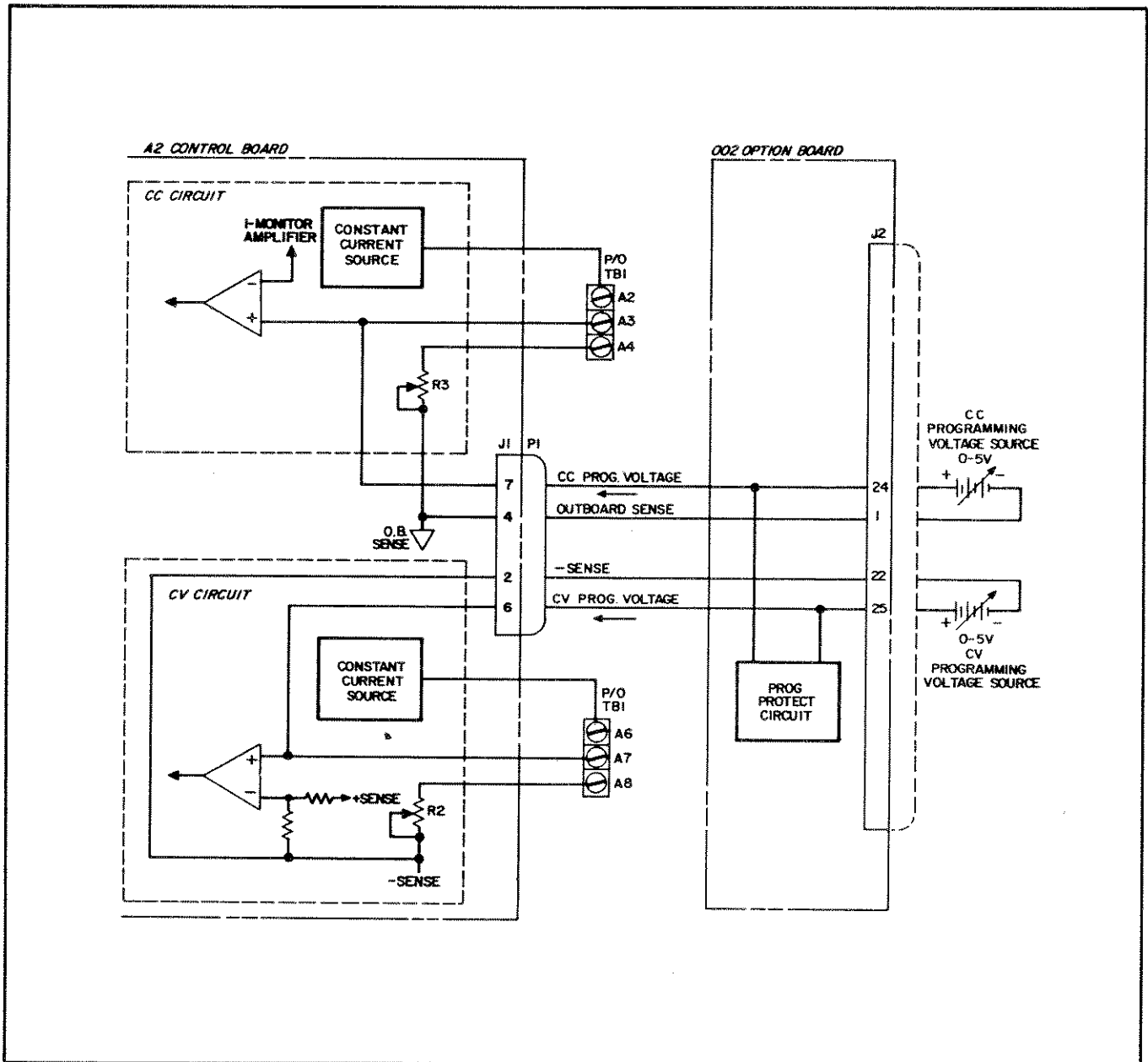

Figure A-4. Voltage Programming of Output Voltage And/Or Current

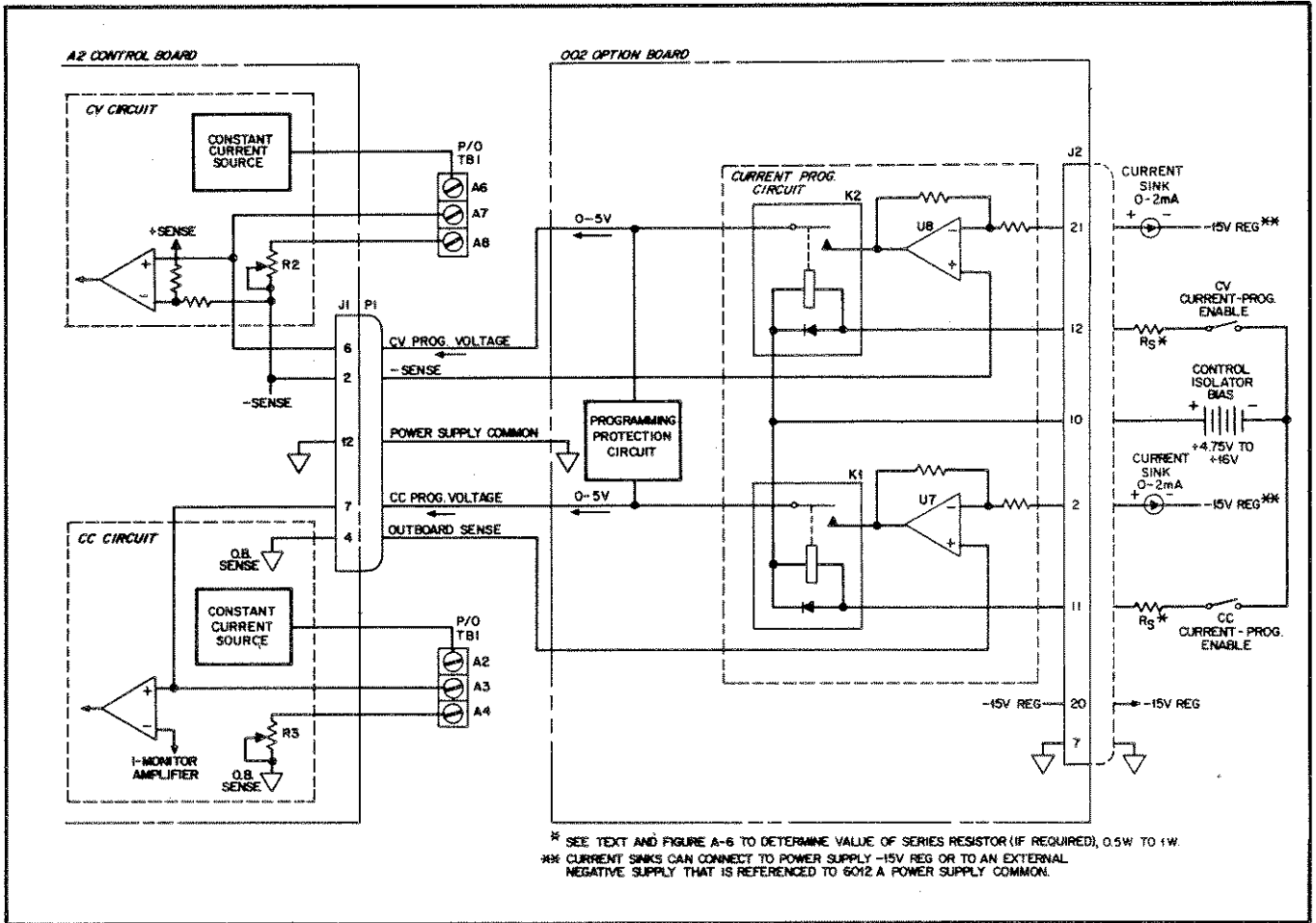

Figure A-5. Current Programming Output Voltage And/Or Current

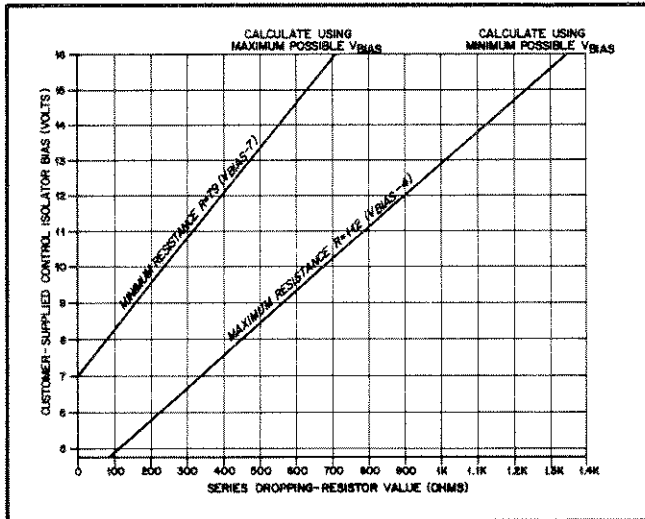

Figure A-6. Calculating Value of Series Dropping Resistor

A-29 To program voltage, the current sink should be connected from J2-21 (CV CURRENT PROG) to J2-20 (-15 V REG). To program current, the current sink should be connected from J2-2 (CC CURRENT PROG) to J2-20.

A-30 The 0 to 2 mA current sink will cause the output of op-amps U8 and U7 to vary proportionally from 0 to 5 volts. With relays K2 and K1 energized, these signals are coupled to the CV and CC circuits (in the main supply) which, in turn, will program the supply's output from 0 to full scale.

A-31 If the programming lines become open circuited (user's system becomes disconnected from J2) during current programming, the Programming Protection circuit will bring the power supply output to zero.

A-32 Remote Monitoring

A-33 The 002 Option board includes a voltage divider to provide a 0 to 5 V output corresponding to a 0 to full scale voltage output. The voltage monitor output is available between pins J2-5 (Voltage Monitor) and J2-22 (- Sense). Output impedance is 8.3 k Ω ; the monitoring device input impedance should be at least 1 M Ω to limit error to 1% + basic accuracy, 10 M Ω to limit error to 0.1% + basic accuracy.

A-34 The I-Monitor signal from the mainframe is also brought out through the 002 option board. A 0 to 5 V output corresponds to a 0 to full scale current output. The current-monitor output is available between pins J2-3 (Current

Monitor) and J2-1 (Outboard Sense). Output impedance is 10k Ω ; the monitoring device input impedance should be at least 1 M Ω to limit error to 1% + basic accuracy, 10 M Ω to limit error to 0.1% + basic accuracy.

A-35 In some applications it may be desirable to install a noise-suppression capacitor on these monitor outputs to lessen the effects of noise induced in the monitor leads. The capacitors should be ceramic or tantalum type, from 0.1 to 1 μ F. The capacitor is installed directly across the monitor device input terminals.

A-36 Status Indicators

A-37 Six optically isolated lines provide open collector digital outputs which indicate certain modes and conditions of power supply operation. For proper operation of the opto-isolator, the user must supply the bias voltage, STATUS ISOLATOR BIAS. This voltage can be from +4.75 V to +16 V depending upon the user's interface circuits. Refer to the specification Table A-1. Connect the bias voltage (+) between J2-37, STATUS ISOLATOR BIAS, and J2-34 (STATUS ISOLATOR COMMON). The status indicator outputs are open-collector (referenced to STATUS ISOLATOR COMMON); therefore, it is necessary to connect a pull-up resistor from each output to STATUS ISOLATOR BIAS. When choosing the resistor value, observe the current sink capabilities of these lines as described in the Specifications Table A-1.

A-38 Because of the relatively slow rise and fall times of opto-isolators, Schmitt-triggered devices should be used to interface these output lines to logic circuits.

A-39 The following signals are in active-low form:

- CV MODE, J2-36, indicates that the power supply is in constant voltage operation.
- CC MODE, J2-35, indicates that the power supply is in constant current operation.
- OUTPUT UNREGULATED, J2-18, indicates that the power supply is in neither constant voltage nor constant current operation and cannot be guaranteed to meet specifications.
- OVERVOLTAGE, J2-17, indicates power supply shutdown because of: the voltage output exceeding the OVP trip point set at the front panel; or, a system-initiated shutdown as described in Section A-45.
- OVERTEMPERATURE, J2-16, indicates power supply shutdown due to an excessive temperature rise on the FET or output diode heatsink.

A-40 The LOW BIAS OR AC DROPOUT signal, J2-19, is in active-high form. This signal indicates: loss of primary power, momentary AC dropout, or "brownout" conditions where the AC line voltage drops below approximately 70% nominal.

A-41 Remote Control

A-42 For proper operation of the opto-isolators, the user must supply the bias voltage, CONTROL ISOLATOR BIAS. This voltage can be from +4.75 to +16 V depending on the requirements of the driving circuits. The type of driving logic and resultant bias voltage also determine the amplitude of the "high" and "low" logic levels. Refer to the Specification Table A-1.

A-43 Connect the bias voltage (+) to J2-10, CONTROL ISOLATOR BIAS, and reference the input signals to this bias supply's negative terminal.

A-44 Two optically isolated methods of remote control are available. They are described in the following paragraphs.

A-45 **Remote Trip.** A negative-going edge applied at input J2-30 (REMOTE TRIP) will shut down the power supply, reducing its output voltage to near zero. For minimum pulse duration and timing considerations with respect to REMOTE RESET, see Table A-1. The following paragraph provides a brief circuit description (see schematic diagram and Figure A-7.)

A-46 A negative-going edge at REMOTE TRIP is coupled through opto-isolator U5 and sets the Trip/Reset latch output "low." This shuts down the supply by pulling down the OV STATUS INHIBIT line (J1-1), which inhibits the Pulse Width Modulator. It also lights the OVP indicator on the front panel and results in the generation of an OVERVOLTAGE status signal from opto-isolator U1. This signal does not affect the state of the power supply's OVP circuit.

A-47 **Remote Reset.** A negative-going edge applied at input J2-29 (REMOTE RESET) will return the supply to its initial state following a system-initiated shutdown (REMOTE TRIP) or an OVP shutdown caused by a temporary overvoltage condition. For minimum pulse duration and timing considerations with respect to REMOTE TRIP, see Table A-1. The following paragraphs provide a brief description of this circuit (see schematic diagram and Figure A-7).

A-48 The negative-going pulse applied at REMOTE RESET is coupled through opto-isolator U4 and resets the Trip/Reset latch output "high". This releases the OV STATUS INHIBIT line and the Pulse Width Modulator.

A-49 The REMOTE RESET pulse will also reset the power supply OVP circuit in the event that an overvoltage condition has shut down the supply. This is accomplished through Q4 after the one-second time delay of one-shot U11A. This delay allows the Down Programmer (paragraphs 4-36 to 4-38) to lower the output from its overvoltage condition to zero before the supply can be reactivated.

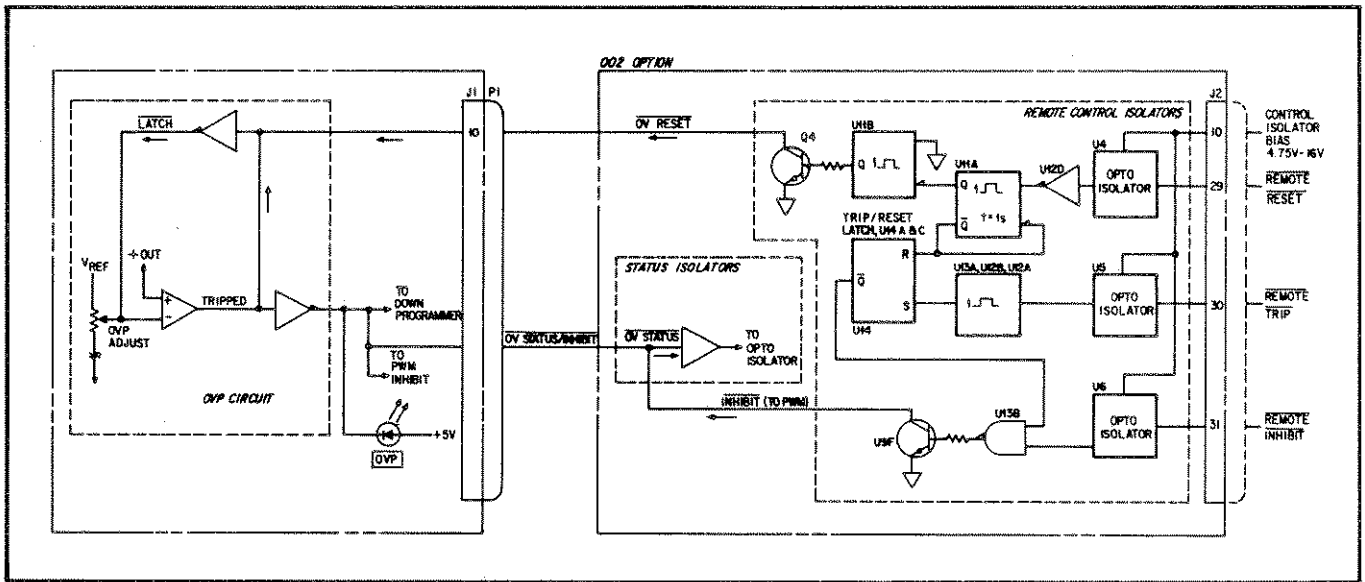

Figure A-7. Remote Control

NOTE

By observing the OVERVOLTAGE status indicator or power supply's output while applying a reset pulse to REMOTE RESET, the user can determine the cause of the shutdown. If the output returns and OVERVOLTAGE goes high immediately, this indicates a controller-initiated shutdown. If the output takes about one second to return, this indicates that the output voltage had exceeded the OVP trip point. If the OVP circuit trips continually, check the load and/or the trip point setting.

A-50 Alternate Method of Remote Control. The REMOTE INHIBIT input, J2-31, provides an alternate method of remote shutdown. By maintaining a low logic level at this input, the supply's output will be inhibited until REMOTE INHIBIT is returned to its initial high state. The following paragraph provides a brief description of this circuit (see schematic diagram and Figure A-7).

A-51 A low logic level at REMOTE INHIBIT is coupled through opto-isolator U6 and causes U9F to inhibit the supply and light the OVP indicator in the same manner as the REMOTE TRIP input of paragraph A-49. Note that this action does not affect the Trip/Reset latch and, therefore, the supply can be returned to its initial state by switching the REMOTE INHIBIT input to a high logic level.

A-52 Power-On Preset

A-53 This open-collector output line, J2-6, provides a logic low pulse (POWER-ON PRESET) that can be used to initialize or delay system operation until the +5 V REG bias supply in the 6012A has stabilized. The pulse is generated after primary power is turned on, and also after resumption of power following momentary ac dropout or brownout conditions in which ac line voltage drops below approximately 70% of nominal. See Table A-1 for POWER-ON PRESET signal specifications.

A-54 Low Bias Or AC Dropout Buffers. These circuits distribute the ORed outputs of the AC Dropout and Bias Voltage Detector circuits in the 6012A mainframe (paragraphs 4-42 through 4-48). The input signal arrives at J1-13 in active-low form and is distributed active-high to opto-isolator U1 and to the Power-On Preset circuit.

A-55 Multiple Supply System Shutdown

A-56 When using more than one 002-equipped power supply in a system, it may be desirable to implement a system shutdown. In this configuration, an OVP trip or remote shutdown of a single unit will cause all of the supplies to shut down.

A-57 Figure A-8 shows one method of system shutdown. The advantages of this method are that one common is used for all status and control lines (useful for controller-operated systems), and the capability of system reset. As shown in Figure A-8, one supply's OVERVOLTAGE line is connected to the next supply's REMOTE TRIP line, and so on in a continuous chain.

NOTE

+5 V REG/POWER SUPPLY COMMON from Supply 1 can be used instead of the bias voltage from the controller. However, because of current limits of the +5 V REG, no more than four units can be connected together in this configuration. To prevent ground loops, do not parallel connect +5 V REG from more than one supply.

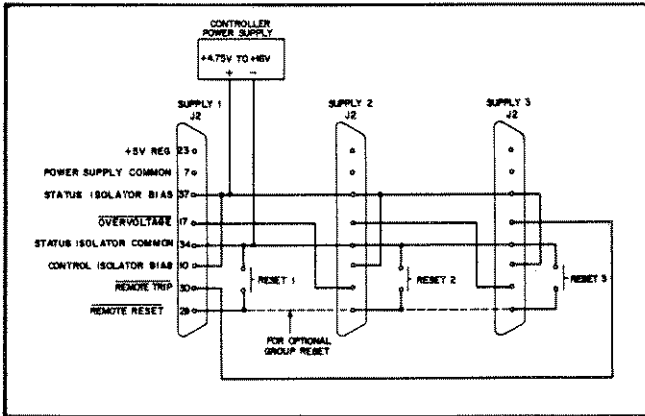

Figure A-8. System Shutdown Using Controller Power Supply

A-58 The note following Paragraph A-49 tells how to determine if a shutdown was initiated through the remote trip line or by a supply's OVP. This allows the controller to determine which supply initiated a system shutdown.

A-59 Following a multiple supply shutdown, each unit can be reset individually or all the REMOTE RESET lines can be tied together for a system reset.

A-60 If it is necessary to have all the supplies come up simultaneously after a system shutdown, follow this procedure:

- First bring the REMOTE INHIBIT line low.
- Provide a negative-going pulse to the REMOTE RESET lines.
- After at least one second, return REMOTE INHIBIT to a high level.

A-61 Figure A-9 shows a second method of system shutdown. This method is appropriate in systems which are not controller-operated and in which more than four supplies must be shutdown simultaneously. Because each supply derives its CONTROL ISOLATOR BIAS from the previous supply's +5V REG, there is no limit to the number of supplies that can be shutdown. Each supply must be reset individually.

A-62 Using either method of system shutdown, LOW BIAS OR AC DROPOUT inhibits the OVERVOLTAGE indicator from going low and shutting down succeeding supplies upon initial turn-on. After the supplies have stabilized, LOW BIAS OR AC DROPOUT returns to a high state.

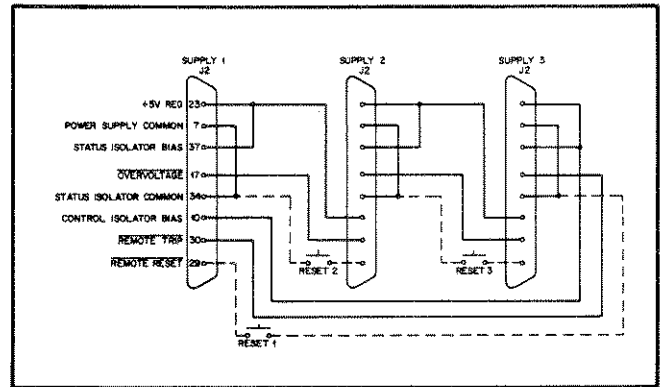

Figure A-9. System Shutdown Using 6012A Bias Supply Output

A-63 Remote/Local Programming

A-64 When using current programming of output voltage and/or current, it is possible to leave the front-panel controls operable. This allows the user to switch back and forth between remote and local programming while initially checking out a current-programming system. For this function, the 6012A rear-panel terminal strip must be strapped as shown in Figure 3-3. The front-panel VOLTAGE and CURRENT controls must be turned fully CW to avoid loading the 002 current-programming circuit. With the CURRENT PROG ENABLE lines (J2-11 and J2-12) low, relays K2 and K1 are closed and remote programming is enabled. Opening the CURRENT PROG ENABLE lines (high logic level) returns control to the front-panel pots.

CAUTION

When switching to local control, output voltage and current will go to full scale. Remember to set the VOLTAGE and CURRENT controls to safe levels before switching to local control, and remember to turn the VOLTAGE and CURRENT controls fully CW after returning to remote control. Once the system has been checked out, remove the straps from A8, A7, and A6 and from A4, A3, and A2, and program the system remotely.

A-65 Bias Supplies

A-66 The outputs of three current-limited bias supplies are available for user-supplied circuitry. These are +15 V @ 75 mA at J2-4, -15 V @ 75 mA at J2-20, and +5 V @ 100 mA at J2-23; all with respect to J2-7, power supply common. Six screwdriver-adjustable pots located at the top of the option board set the output voltages and current limiting points of these supplies (refer to Specification Table A-1).

CAUTION

Although the bias supplies are current limited, it is important to avoid shorting the ± 15 V supplies to common. These supplies are used internally for the current programming circuit. Shorting them could cause improper programming of the power supply and possible damage to the user's load.

A-67 It may be desirable to install noise-suppression capacitors on the bias supply outputs near the load circuits. The capacitors should be ceramic or tantalum type, approximately $0.1\mu\text{F}$ to $10\mu\text{F}$.

A-68 MAINTENANCE

A-69 The following paragraphs provide procedures and set-ups to aid in checking and troubleshooting the 002 option board. This information, used in conjunction with the schematic drawing and the Operation section of this Appendix, will help in the isolation and repair of faulty circuits.

A-70 The adjustments on the option board set the voltage output and current limiting of the three Bias Supplies. Although these potentiometers are set at the factory, calibration procedures are provided for purposes of checking performance and to aid in troubleshooting of these supplies.

A-71 When testing the option, use of the test connector of paragraph A-17 will allow easier access to the J2 contacts.

A-72 Troubleshooting

A-73 Before attempting to troubleshoot the 002 option board, ensure that the fault is with the option itself and not with the main supply. This can be accomplished by removing the top cover, disconnecting ribbon connector P1 from the A2 Control Board and checking the operation of the main supply. If the fault still exists, proceed to the troubleshooting section, paragraph 5-52, in the main text. Otherwise, troubleshoot the option board as described in the following paragraphs.

A-74 **Removal of the Option Board.** To facilitate troubleshooting of the 002 option, the board can be removed from the power supply and electrically connected via the ribbon cable. To remove the circuit board, proceed as follows:

- Turn off power supply and disconnect line cord.
- Disconnect option board ribbon cable from J1 on A2 control board, and remove control board as directed in Paragraph A-15.
- Disconnect option I/O cable from J2 on rear panel, remove two screws that secure option connector to rear panel, remove two screws that secure option board to side panel, and remove option board from instrument.
- Reinstall control board.
- With 6012A top cover still off, place a piece of cardboard or other lightweight insulating material on top of 6012A and lay option board, component side up, on top of insulating material.

- Being careful not to damage ribbon cable by excessive stretching or flexing, reconnect option board ribbon cable (P1) to J1 on control board. Red stripe on ribbon cable should be toward end of J1 marked with white dot (toward front of instrument).
- Be careful that option board lies securely on insulating material and does not touch any part of the 6012A.

A-75 Isolating Faulty Circuit. If it is apparent which function is not operating properly, proceed to the appropriate paragraph. If the problem involves more than one function, check the output voltages of the Bias Supplies. (Table A-1).

A-76 Troubleshooting Resistance and Voltage Programming.

- Confirm that problem is on option board by disconnecting P1 from Control Board and attempting to program the supply via the rear panel terminal strip.
- Check -15 V and ± 11.8 V supplies.
- Check for a problem in the Programming Protection circuit. This circuit should draw about $2\mu\text{A}$ from the programming lines.
- Check for shorted relay contacts on K1 and K2.

A-77 Troubleshooting Current Programming.

- Check ± 15 V supplies.
- Check $+5$ V supply and proceed to the test set-up shown in Figure A-10 and/or A-11.
- Disconnect J2-11 and/or J2-12 from J2-7. See if varying the voltage source produces 0 to 5 V at K1, pin 14 and/or K2, pin 14. If not, check op amps and associated circuitry.
- Return to original test set-up and see if varying the voltage source produces 0 to 5 V at K1, pin 8 and/or K2, pin 8. If not, check relays for proper operation.
- If relays are okay, check for a problem in the Programming Protection circuit. This circuit should draw about $2\mu\text{A}$ from the programming lines.

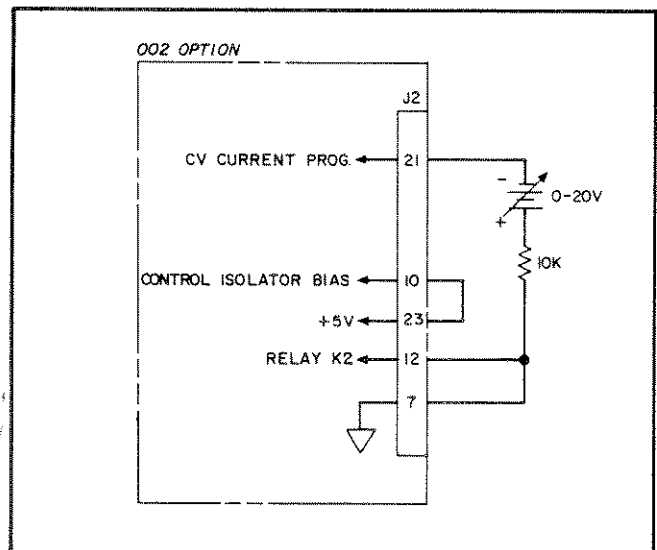

Figure A-10. Troubleshooting Current Programming of CV Mode

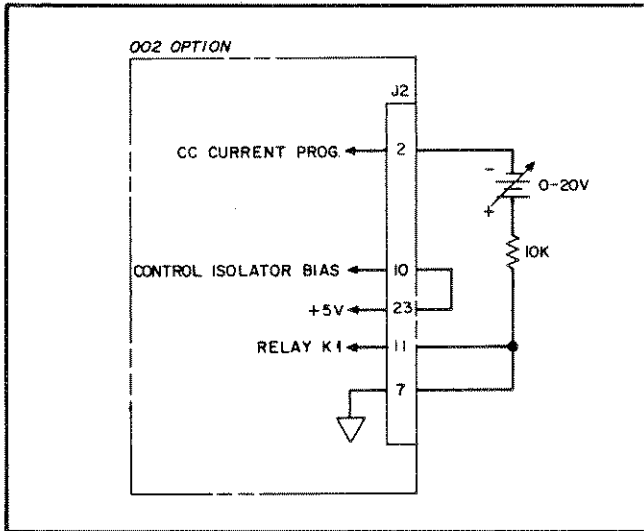

Figure A-11. Troubleshooting Current Programming of CC Mode

A-78 Troubleshooting Status Indicators. The test set-up shown in Figure A-12 can be used to check each of the six status indicators. This set-up, however, will temporarily defeat the isolation of the status lines. Before attempting to troubleshoot a status indicator, check for +5 V at TP1 (+5 V INT). This voltage must be present for proper operation of the opto-isolators.

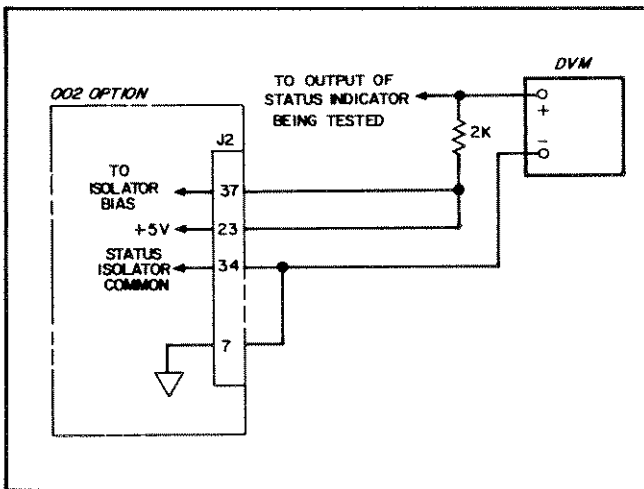

Figure A-12. Troubleshooting Status Indicators

- A-79 To check CV MODE, proceed as follows:**
- Using test set-up, connect top end of 2 K Ω resistor to J2-36.
 - Set CURRENT control one turn clockwise (CW) and VOLTAGE control also one turn CW.
 - Turn unit on. DVM should read 0 to .4 V.
 - Turn unit off. Short circuit the supply's output.
 - Turn unit on. DVM should read about 5 V.

- A-80 To check CC MODE, proceed as follows:**
- Using test set-up, connect top end of 2 k Ω resistor to J2-35.

- Set CURRENT and VOLTAGE controls one turn CW.
- Turn unit on. DVM should read about 5 V.
- Turn unit off. Short circuit the supply's output.
- Turn unit on. DVM should read 0 to .4 V.

- A-81 To check OVERVOLTAGE, proceed as follows:**
- Using test set-up, connect top end of 2 k Ω resistor to J2-17.
 - With no load on supply, turn OVP ADJUST fully CW and set VOLTAGE control for about 30 volts output. Turn CURRENT control one turn CW.
 - Turn OVP ADJUST CCW one-half turn or until the supply goes into overvoltage. DVM should read 0 to .4 V
 - Turn OVP ADJUST fully CW, turn supply off and wait several seconds.
 - Turn supply on. DVM should read about 5 volts.

- A-82 To check OUTPUT UNREGULATED, proceed as follows:**
- Using test set-up, connect top end of 2 k Ω resistor to J2-18.
 - With no load on supply, turn OVP ADJUST fully CW and set VOLTAGE control for about 30 volts output. Turn CURRENT control one turn CW.
 - Turn OVP ADJUST CCW one-half turn or until the supply goes into overvoltage. DVM should read 0 to .4 V.
 - Turn OVP ADJUST fully CW, turn supply off and wait several seconds.
 - Turn supply on. DVM should read about 5 volts.

- A-83 To check LOW BIAS OR AC DROPOUT, proceed as follows:**
- Substitute an oscilloscope in place of DVM in test set-up.
 - Connect top end of 2 k Ω resistor to J2-19.
 - Turn unit on. Voltage at 2 k Ω resistor should be between 0 and .4 V.
 - Turn unit off. Voltage at 2 k Ω resistor should go to about 5 volts before decaying back to 0V.

NOTE

In this test, the LOW BIAS OR AC DROPOUT signal decays to 0 V only because of loss of power to the +5 V REG Bias Supply used in the test set-up. If in doubt, use an external +5 V supply for this test.

- A-84 To check OVERTEMPERATURE, proceed as follows:**
- Turn off power supply and disconnect line cord.
 - Wait at least two minutes for input capacitors to discharge.
 - Remove top cover and remove heatsink cover.
 - Using test set-up, connect top end of 2 k Ω resistor to J2-16.
 - Connect a SPST switch across any one of the three thermostats in the 6012A. One thermostat is mounted on each of the three heatsink assemblies. The ther-

mostat on the Output Diode assembly, mounted in A1J3 (furthest to the right) is the most accessible.

- f. Ensure that all three heatsink assemblies are standing straight up and not touching one another or any part of the 6012A chassis.
- g. Reconnect 6012A line cord and turn unit on.

WARNING

The FET heatsinks are connected to the 6012A primary circuit, and hazardous voltages (up to between 300 V and 400 V dc) exist between each of the heatsinks and between the heatsinks and the 6012A chassis. These potentials remain for up to two minutes after the 6012A is turned off. Do not touch the heatsinks or any components on the heatsink assemblies while the 6012A is turned on or for at least two minutes after primary power is turned off. Do not place any of the heatsink assemblies on extender boards.

- h. With SPST switch open, DVM should read about 5 volts.
- i. Close SPST switch. DVM should read 0 to .4 V.
- j. Turn off power supply and disconnect line cord.
- k. Wait at least two minutes for input capacitors to discharge, and disconnect SPST switch from thermostat.
- l. Replace heatsink cover, top cover, and reconnect line cord.

A-85 Troubleshooting Remote Shutdown. The following procedures check the Remote Shutdown features of the option. Troubleshooting can be accomplished by using a logic probe and referring to the schematic and the circuit descriptions in Section A-46. Before attempting to troubleshoot the Remote Shutdown function of the option, check for +5 V at TP1 (+5 V INT.). This voltage must be present for proper operation of these circuits.

A-86 To check REMOTE TRIP and REMOTE RESET, proceed as follows:

- a. Connect +5 V supply, J2-23, to CONTROL ISOLATOR BIAS, J2-10.
- b. Turn unit on and short REMOTE TRIP, J2-30, to power supply common, J2-7, momentarily. Supply should go into overvoltage condition.
- c. Short REMOTE RESET, J2-29, to common momentarily. Supply should return to initial state.

A-87 To check REMOTE INHIBIT, proceed as follows:

- a. Connect ± 5 V supply, J2-23, to CONTROL ISOLATOR BIAS, J2-10.
- b. Turn unit on and short REMOTE INHIBIT, J2-31, to power supply common, J2-7. Supply should go into overvoltage condition.
- c. Remove short from J2-31 to common. Supply should return to its initial state.

A-88 Bias Supply Adjustments

A-89 After troubleshooting and repair of the 002 option, it may be necessary to calibrate the Bias Supplies. The correct calibration procedures are provided in the following paragraphs. Measurements can be taken at the appropriate pins on connector J2 and adjustments are made with the six potentiometers located on the top of the option board.

A-90 To remove the top cover of the power supply, remove the four screws that secure the cover to the instrument. Slide the cover back and lift off.

A-91 +5 V Supply Adjustment. The output voltage and current limiting of the +5 V Bias Supply are adjusted as follows:

- a. Turn off supply and disconnect all loads.
- b. Connect a DVM between J2-23 (+5 V) and J2-7 (power supply common).
- c. Turn on power supply and adjust R43 until DVM reads $+5\text{ V} \pm 25\text{ mV}$.
- d. Turn off power supply and disconnect DVM.
- e. Connect 10 Ω , 5 watt resistor between J2-23 and J2-7. Connect DVM across this resistor.
- f. Turn on power supply and adjust R44 until DVM reads $1.7\text{ V} \pm 50\text{ mV}$. This limits the output current to 170 mA.
- g. Turn off power supply and disconnect DVM and resistor.

A-92 +15 V Supply Adjustment. The output voltage and current limiting of the +15 V Bias Supply are adjusted as follows:

- a. Turn off supply and disconnect all loads.
- b. Connect a DVM between J2-4 (+15 V) and J2-7 (power supply common).
- c. Turn on supply and adjust R45 until DVM reads $+15\text{ V} \pm 75\text{ mV}$.
- d. Turn off power supply and disconnect DVM.
- e. Connect 50 Ω 5 watt resistor between J2-4 and J2-7. Connect DVM across this resistor.
- f. Turn on supply and adjust R46 until DVM reads $\pm 6.25\text{ V} \pm 0.15\text{ V}$. This limits the output current to 125 mA.
- g. Turn off supply and disconnect DVM and resistor.

A-93 -15 V Supply Adjustment. The output voltage and current limiting of the -15 V Bias Supply are adjusted as follows:

- a. Turn off supply and disconnect all loads.
- b. Connect a DVM between J2-20 (-15 V) and J2-7 (power supply common).
- c. Turn on supply and adjust R48 until DVM reads $-15\text{ V} \pm 75\text{ mV}$.
- d. Turn off power supply and disconnect DVM.
- e. Connect 50 Ω 5 watt resistor between J2-20 and J2-7. Connect DVM across this resistor.
- f. Turn on supply and adjust R47 until DVM reads $-6.25\text{ V} \pm 0.15\text{ V}$. This limits the output current to 125 mA.
- g. Turn off supply and disconnect DVM and resistor.

Table A-3. Replaceable Parts

Ref. Desig.	HP Part No.	Qty.	Description	Mfr. Code	Mfr. Part No.
C1, 3, 13	0160-3070	2	cap 100pF 5% 300 V mica	28480	
C2,11	0160-4822	1	cap 1000pF 5% 100 V cer	16299	XX03COG102J100A
C4, 6	0160-2639	1	cap 5000pF 20% 100 V cer	72982	835-100-Z5U-502M
C5, 7, 14, 18, 31	0160-4722	5	cap .1 μ F -20 + 80% 50 V cer	56289	292CZ5U104Z050C
C8, 9	0140-0210	1	cap 270pF 5% 300 V mica	28480	
C10, 24	0160-4832	2	cap .01 μ F 10% 100 V cer	16299	CAC03X7R103K100A
C12, 16, 17	0180-0405	3	cap 1.8 μ F 10% 20 V	56289	150D185X9020A2
C15	0160-2012	1	cap 330pF 5% 500 V mica	28480	
C19	0160-0157	1	cap 4700pF 10% 200 V	56289	192P47292
C20, 30	0180-2825	2	cap 22 μ F -10 + 50% 50 V	28480	
C21	0160-3969	1	cap .015 μ F 20% \pm 20pF	C0633	PME271Y515
C22, 23	0180-0533	2	cap 500 μ F +75 -10% 40 V al	28480	
C25	0160-4557	2	cap .1 μ F 20% 50 V cer	16299	CAC04X7R104M050A
C26	0180-2407	1	cap 1000 μ F +75 -10% 25 V al		
C27	0160-4830	1	cap 2200pF 10% 100 V cer	16299	CAC02X7R222K100A
C28	0160-4833	1	cap .022 μ F 10% 100 V cer	16299	CAC04X7R223K100A
C29	0180-0100	1	cap 4.7 μ F 10% 35 V	56289	150D475X9035B2-DYS
CR1, 2, 3, 16, 17	1901-0327	5	dio-pwr rect. 200 V 1A	03508	A14B
CR4,9,10,11, 12,14,15	1901-0033	7	dio-gen prp	07263	FDH3369
CR5-8, 13, 18, 19	1901-0050	7	dio-sw 80 V 200 mA	07263	FDH6308
J2	1251-6075	1	connector, F 37-pin	28480	
K1, 2	0490-1277	2	relay, reed	28480	
Q1-4	1854-0823	4	XSTR NPN si	01295	SKC0221
Q5-7	1853-0234	3	XSTR PNP si	01295	TIP42A
R1-3	0683-2015	3	res 200 Ω 5% .25W fc	01121	CB2015
R4-6	0686-1525	3	res 1.5k 5% .5W fc	01121	EB1525
R7-9, 13, 21	0683-4715	5	res 470 Ω 5% .25W fc	01121	CB4715
R10, 12	0683-3355	2	res 3.3m 5% .25W fc	01121	CB3355
R11	0757-0441	1	res 8.25k 1% .125W f	16299	C4-1/8-TO-8251-F
R14, 38	0683-4315	2	res 430 Ω 5% .25W fc	01121	CB4315
R15, 18	0698-6631	2	res 2.5k .1% .125W f	24546	NE55
R16, 17	0683-1055	2	res 1M 5% .25W fc	01121	CB1055
R19, 39	0813-0001	2	res 1k 5% 3W w	01686	T2B-79
R20, 22, 42	0683-1035	3	res 10k 5% .25W fc	01121	CB1035
R23, 53	0757-0427	2	res 1.5k 1% .125W f	16299	C4-1/8-TO-1501-F
R24, 52	0683-4725	2	res 4.7k 5% .25W fc	01121	CB4725
R25	0683-3335	1	res 33k 5% .25W fc	01121	CB3335
R26	0698-6343	1	res 9.k .1% .125 W f	91637	CMF-55-1,T-9
R27	0698-4158	1	res 100k .1% .125W f	28480	
R28, 37	0757-0449	2	res 20k 1% .125W f	91637	CMF-55-1,T-1
R29, 33	0683-1535	2	res 15k 5% .25W fc	01121	CB1535
R30	0683-2715	1	res 270 Ω 5% .25W fc	01121	CB2715
R31	0683-2745	1	res 270k 5% .25W fc	01121	CXB2745
R32	0757-0317	1	res 1.33k 1% .125W f	16299	C4-1/8-TO-1331-F
R34	0683-1615	1	res 160 5% .25W fc	01121	CB1615
R35	0683-2725	1	res 2.7k 5% .25W fc	19701	(CR-25)1-4-5P2K7
R36	0757-0400	1	res 90.9 Ω 1% .125W f	16299	C4-1/8-TO-90R9-F
R40	0757-0483	1	res 562k 1% .125W f	28480	

Table A-3. Replaceable Parts (cont.)

Ref. Desig.	HP Part No.	Qty.	Description	Mfr. Code	Mfr. Part No.
R41	0757-0465	1	res 100k 1% .125W f	16299	C4-1/8-TO-1003-F
R43	2100-3273	1	res var 2k 10%	01121	E4A202
R44, 46, 47	2100-0589	3	res var 10 Ω 10% 25W	01121	E4A100
R45, 48	2100-3274	2	res var 10k 10%	01121	E4A103
R49	0686-2225	1	res 2.2k 5% .5W fc	01121	EB2225
R50, 57	0757-0438	2	res 5.11k 1% .125W f	16299	C4-1/8-TO-5111-F
R51	0683-4735	1	res 47k 5% .25W fc	01121	CB4735
R54	0686-1205	1	res 12 Ω 5% .5W fc	01121	EB1205
R55, 59	0683-1025	2	res 1k 5% .25W fc	01121	CB1025
R56	0683-0335	1	res 3.3 Ω 5% .25W fc	01121	CB33G5
R58	0757-0439	1	res 6.81k 1% .125W f	16299	C4-1/8-TO-6811-F
R60	0683-6235	1	res 62k 5% .25W fc	01121	CB6235
R61, 67	0683-3305	2	res 33 Ω 5% .25W fc	01121	CB3305
R62, 66	0683-0275	2	res 2.7 Ω 5% .25W fc	01121	CB27G5
R63	0698-0084	1	res 2.15k 1% .125W f	16299	C4-1/8-TO-215R-F
R64	0683-3325	1	res 3.3k 5% .25W fc	01121	CB3325
R65	0683-1525	1	res 1.5k 5% .25W fc	01121	CB1525
U1-3	1990-0732	3	Opto-isolator	28480	
U4-6	1990-0494	3	Opto-isolator	28480	
U7, 8	1826-0493	2	IC LM308A	27014	SL35068
U9	1858-0023	1	XSTR Array NPN si	86684	CA3081E
U10	1820-1976	1	IC-MC14050BCP	04713	SC45023PK
U11	1820-1932	1	IC-MC14538BCP	04713	SC42853PK
U12	1820-2019	1	IC-MC14584BCP	04713	SC45115PK
U13	1820-1600	1	IC-MC14093BCP	04713	SC45057PK
U14	1820-1961	1	IC-MC14023BCP	04713	SC45010PK
U15	1826-0144	1	IC Voltage Reg, +5 V	07263	7805UC
U16, 17	1826-0049	2	IC Voltage Reg., Adj., Pos.	01295	UA723CJ
U18	1826-0016	1	IC Voltage Reg., Adj., Neg.	04713	MLM2046
VR1-8,11,14	1902-0556	10	dio-znr 20 V 5%	04713	SZ11213-227
VR9	1902-0575	1	dio-znr 6.5 V 2%	12954	SZ11594
VR10	1902-0064	1	dio-znr 7.5 V 5%	28480	
VR12	1902-3180	1	dio-znr 11.8 V 2%	04713	SZ30016-204
VR13	1902-0779	1	dio-znr 11.8 V 5%	04713	SZ11213-161
Z1	1810-0276	1	res array 1.5k 2%	01121	210A152
Z2	1810-0206	1	res array 10k 2%	01121	208A103

Table A-3. Replaceable Parts (cont.)







Ref. Desig.	HP Part No.	Qty	Description	Mfr. Code	Mfr. Part No.
OPTION BOARD ASSEMBLY					
	06012-60005	1	cable assy, 16 conductor with connectors	28480	
MECHANICAL					
	1205-0398	3	heat sink al (Q5-7)	13103	6025D
	1251-4150	1	connector 37 pin M	28480	
	1251-6069	37	contacts-crimp	28480	
	1251-6070	1	shield and hardware for 37 pin connector	28480	
	2360-0411	2	6-32 screw	28480	
	06024-00014	1	bracket (J2)	28480	
	1251-5436	1	screwlock F (J2)	28480	
MISCELLANEOUS					
	06012-90002	1	Option 002 Manual	28480	

Figure A-13. Logic Symbols And Definitions

Definitions

High = more positive
 Low = less positive

Indicator and Qualifier Symbols

-  OR function
-  (polarity indicator, shown outside logic symbol) Any marked input or output is active low; any unmarked input or output is active high.
-  (dynamic indicator) Any marked input is edge-triggered, ie, active during transition between states; any unmarked input is level sensitive.
-  (Schmitt trigger) indicates that hysteresis exists in device.
-  (non-logic indicator) Any marked input or output does not carry logic information.
-  open-collector or open emitter output
-  monostable (one-shot) multivibrator
- $t = x\text{Sec}$ indicates pulse width (usually determined by external RC network)
- G gate input (a number following G indicates which inputs are gated)
- C control input (clock)
- R reset (clear)
- S set

OLD SYMBOL

NEW SYMBOL

NOTES

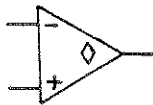

Output requires external components to achieve logic state

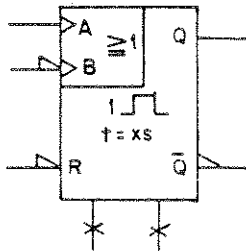
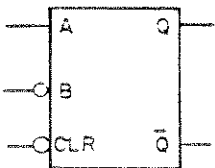

A positive-going transition at A or a negative-going transition at B triggers the one-shot. External timing components connect to non-logic inputs.



Output changes state rapidly regardless of input rate of change.

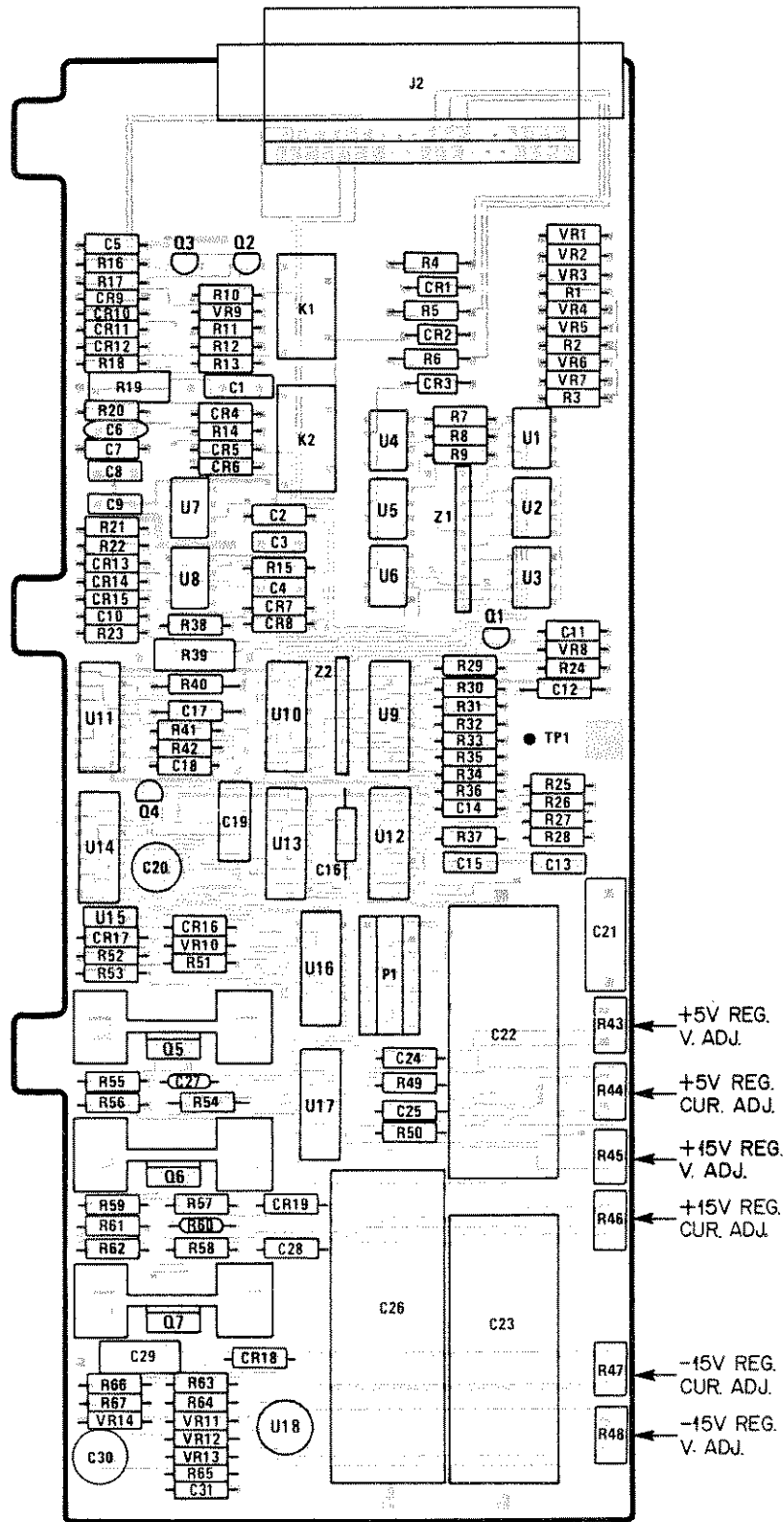
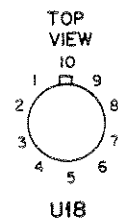
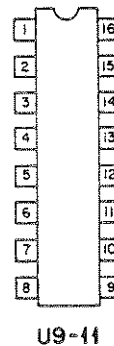
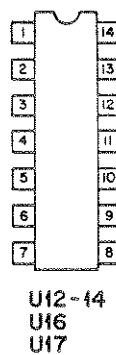
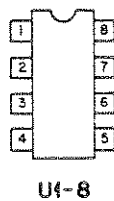
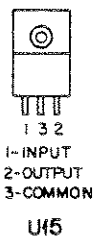
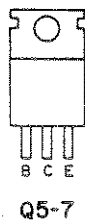

Figure A-14. Option 002 Board Component Location

SCHEMATIC NOTES:

1. ALL RESISTORS ARE IN OHMS, $\pm 5\%$, 1/4W, UNLESS OTHERWISE INDICATED.
2. ALL CAPACITORS ARE IN MICROFARADS, UNLESS OTHERWISE INDICATED.
3. WHITE SILKSCREENED DOTS ON P.C. BOARDS INDICATE ONE OF THE FOLLOWING:
 - A. PIN 1 OF AN I.C. (EXCEPT FOR U18, SEE NOTE 4).
 - B. POSITIVE END OF A POLARIZED CAPACITOR.
 - C. CATHODE OF A DIODE OR THE EMITTER OF A TRANSISTOR.
4. PIN LOCATIONS FOR SEMICONDUCTORS ARE SHOWN BELOW:



5. ON VOLTAGE REGULATOR DEVICES,
 - REF SUPPLY = BIAS FOR REGULATORS INTERNAL REFERENCE.
 - REF = OUTPUT FROM REGULATORS INTERNAL REFERENCE.
 - BOOST OUTPUT = CONTROL FOR EXTERNAL PASS TRANSISTOR.
 - C_S = CURRENT SENSE
 - C_L = CURRENT LIMIT
 - INV = INVERTING INPUT TO REGULATORS ERROR AMPLIFIER.
 - NI = NON-INVERTING INPUT TO REGULATORS ERROR AMPLIFIER.
 - COMP = FREQUENCY COMPENSATION.

APPENDIX B

100 Vac INPUT POWER OPTION 100

B-1 GENERAL INFORMATION

B-2 Description

B-3 Option 100 is a modification of Model 6012A that involves changing the values of two resistors, located in the Overvoltage Protection and Display Circuits. It also entails recalibrating the unit and changing the Voltmeter, Ammeter, and the Front panel. These changes allow the unit to operate at a lower line voltage of 90-105 Vac, while operating on the same line frequency of 48 to 63 Hertz. The reduced input voltage limits the output power to 675 W and the output voltage from 0 to 50 V, while retaining the standard unit's output current rating. Other parameters that change due to Option 100 include the Overvoltage Trip Range and The Remote Programming specifications.

B-4 Scope of Appendix B

B-5 This appendix contains all the information necessary to support Model 6012A power supplies that are equipped with Option 100. The appendix describes only the changes pertaining to Option 100 and how they affect the other portions of this manual. Unless otherwise specified in Appendix B, all other portions of the manual apply to both the standard unit and the Option 100 unit.

B-6 Suggestions for Using Appendix B

B-7 The Option 100 changes are listed sequentially, starting with Section I in the main body of the manual and working back through Section VII. It is recommended that the user mark all the necessary changes directly into the manual using Appendix B as a guide. This will update the manual for Option 100 and eliminate the need for constant referrals back to Appendix B.

B-8 Section I Manual Changes

B-9 In paragraph 1-2 change the output power from "at least 1000 W" to "at least 675 W" and the operating range to "from 0 to 50 V".

B-10 In paragraph 1-4, the Overvoltage Trip Point can be set between 2 V and 52 V.

B-11 Specifications Changes

B-12 Table B-1 provides all specifications changes for Option 100. Specifications not listed in Table B-1 are the same as those in the main specifications, Table 1-1.

B-13 INSTALLATION

B-14 Section II Manual Changes

B-15 In paragraph 2-16, the supply can be operated from a nominal 100 V source with the addition of Option 100 and with a derated output. Add the following:

Nominal Voltage	Line Voltage Range	Maximum Input Current
100 V	90-105	24 A rms

B-16 In paragraph 2-18 the power cord used for 120 V operation is also used for the 100 V operation of Option 100.

B-17 In paragraph 2-24, line c; change 22 V to 14.5 V.

B-18 **Line Voltage Option.** It is possible to convert the Option 100 units to other line voltages by following the directions in paragraph 2-25 for 120 V conversion, but the unit will maintain its derated 675 W output.

CAUTION

No attempt should be made by the user to uprate the Option 100 unit above its calibrated output voltage and power limits. To do so could result in severe damage to the unit and a fire hazard.

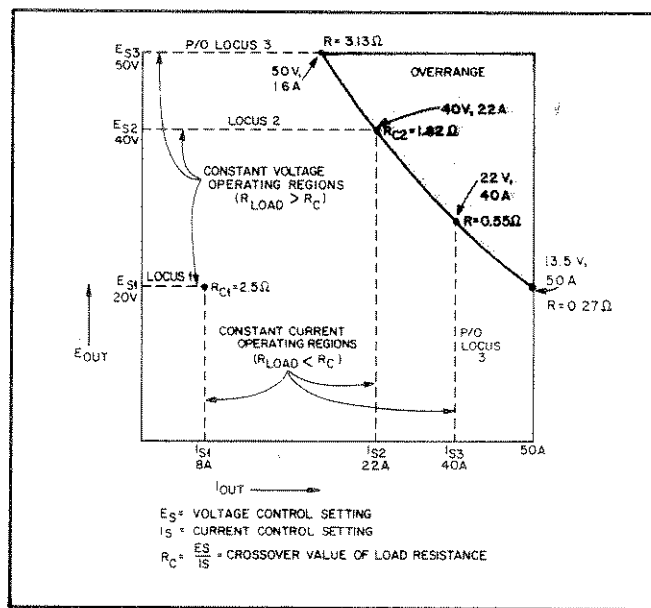

Figure B-1. Overall Output Range with Three Sample Operating Loci (Replace Figure 3-4).

Table B-1. Specification Changes, Model 6012A Option 100

INPUT POWER:

Two internal switches and two internal jumpers permit operation from 100, 120, 220 or 240 Vac (-10%, +5%)48-63 Hz. Maximum input current is 24 A rms for 100 and 120 V rms, 15 A rms for 220 V rms and 14 A rms for 240 V rms.

PEAK INRUSH CURRENT (Maximum)

- 100 Vac, 26.1 A
- 120 Vac, 31.5 A
- 220 Vac, 13.3 A
- 240 Vac, 14.3 A

DC OUTPUT:

Adjustable from 0 to 50 V and 0 to 50 A. Maximum output power is 675 W at 50 A, 800 W at 50 V, and approximately 910 W at midrange (See Graph).

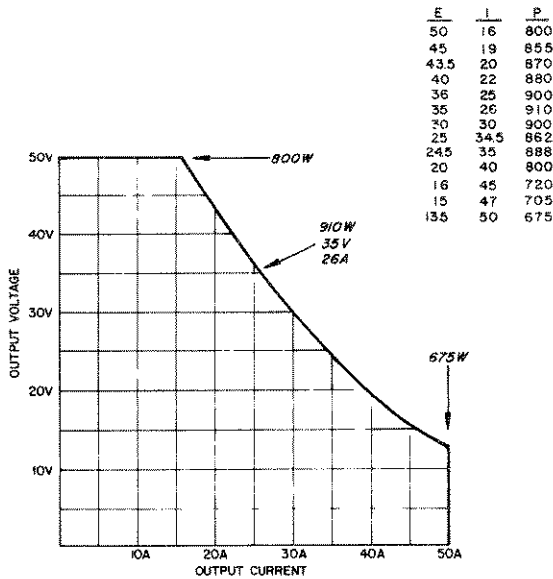

OVERVOLTAGE PROTECTION:

Trip voltage is adjustable from 2 to 52 V. Minimum setting above output voltage to avoid false tripping is 1.5 V + 1% V_{out}.

REMOTE PROGRAMMING:

Resistance Programming - 0 to 2083Ω provides 0 to 50 V and 0 to 2500Ω provides 0 to 10 A.

Accuracy: CV; 1% + 3 mV CC; 2.5% + 15 mA

Voltage Programming - 0 to 4.17 V provides 0 to 50 V and 0 to 5 V provides 0 to 10 A.

Accuracy: CV; 0.3% + 3 mV CC; 1% + 15 mA.

Current Programming - 2 mA to 0 mA current sink provides 0 to 50 V with 2083Ω resistance and 0 to 10 A with 2500Ω resistance.

Accuracy: CV; 0.3% + 0.42 V + accuracy of resistor
CC; 1% + 0.8 A + accuracy of resistor

PROGRAMMING RESPONSE TIME:

Maximum time for output voltage to change from 0 V to 50 V or 50 V to 2 V and settle within the 60 mV band is:

- Up: Full Load (3.1Ω) 120 mS
- No Load 120 mS
- Down: Full Load (3.1Ω) 400 mS
- No Load 1.0 S

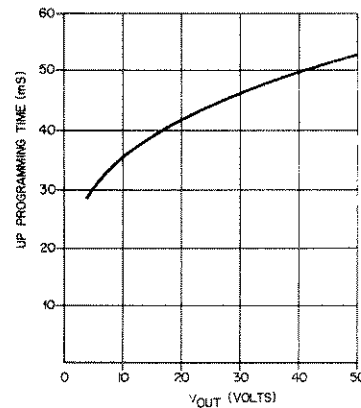
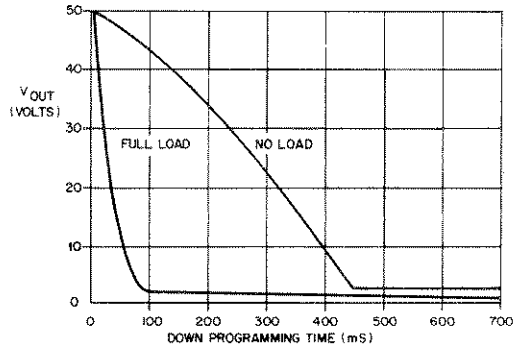

METERS AND INDICATORS:

Continuously reading 60 V scale with secondary scale indicating amperes available; accuracy ±3% of full scale.

MULTIPLE UNIT OPERATION:

Auto-series-Up to four units (eight if center tapped to ground) may be connected in series to increase total output voltage to 200 Vdc (400 Vdc if center tapped to ground) while maintaining control from a single-unit.

B-19 OPERATING INSTRUCTIONS

B-20 Section III Manual Changes

B-21 In paragraph 3-22 (which refers to Figure 3-4 in the manual) the reference illustration is now Figure B-1 instead of Figure 3-4. Also the CURRENT setting should be changed from 30 A to 22 A and the resistance from 1.3 Ω to 1.82 Ω .

B-22 In paragraph 3-24 change the values 2.2 Ω , 2.2 Ω , 0.7 Ω , and 25 V to 3.13 Ω , 3.13 Ω , 0.55 Ω , and 22 V.

B-23 In paragraph 3-25 change 1000 W to 675 W. This should also be done for every remaining 1000 W value in the manual.

B-24 In paragraph 3-32 change 63 volts to 52 volts.

B-25 In paragraph 3-46, 3-51, 3-53, 3-54, and 3-56 change "full scale," or "maximum" or "maximum rated output voltage" to read "0 to 50 V" or "0 to 50 A."

B-26 Remote Programming. In paragraphs 3-46, 3-51, 3-53, 3-54 and 3-56 to obtain the 0-50 V output, different programming values are now necessary for Constant Voltage than those required for Constant Current Output. Resistance Programming requires a 2083 K Ω programming resistance, Voltage Programming requires a 0-4.17 V programming voltage and Current control requires a 2083 K Ω resistance with a 2mA to 0 mA current sink. The Constant Current Output programming values for Option 100 are the same as those shown in the manual.

B-27 In paragraph 3-51 change 2500 Ω to 2083 Ω .

B-28 In paragraph 3-52 change 1250 Ω , 30 V, 1250 Ω , 2500 Ω , and 20 V to 1042 Ω , 25 V, 1042 Ω , 2083 Ω , and 16.67 V.

B-29 In paragraphs 3-53 and 3-54 change "0 to +5 V" to "0 to +4.17 V."

B-30 PRINCIPLES OF OPERATION

B-31 Section IV Manual Changes

B-32 In paragraph 4-2, the reference illustration is now Figure B-2 instead of Figure 4-1. In Figure 4-2 and paragraph 4-9, change the dc input to the FET switches from approximately 300 Vdc to approximately 250 Vdc.

B-33 MAINTENANCE

B-34 Section V Manual Changes

B-35 In paragraphs 5-9; 5-17,c; 5-28,c; 5-44,f; and 5-46,e; and 5-51,c; change 20 V to 13.5 V.

B-36 In paragraph 5-9 change 3.4 Ω to 3.13 Ω .

B-37 In paragraphs 5-9; 5-15,f; 5-38,e; and 5-41,e; change 17.5 A to 16A.

B-38 In paragraphs 5-9; 5-15, c, d, h; 5-19, e; 5-38, c; 5-41, c; Table 5-4, line 6; and 5-103, b, c; change 60 V to 50 V.

B-39 In paragraph 5-9 change 1200 W to 910 W.

B-40 In paragraphs 5-15, f; 5-38, e; and 5-41, e; change 17.5 mV to 16 mV.

B-41 In paragraph 5-19, k; change 9 mV to 8 mV.

B-42 In paragraph 5-24, c; change 40 V and 30 A to 35 V and 26 A.

B-43 In paragraph 5-31 change the values 30 A, 3 A, 0.149 Ω , 1.333 Ω , 1.482 Ω , 30 A and 27 A to 22 A, 2.2 A, 0.202 Ω , 1.818 Ω , 2.020 Ω , 22 A and 19.8 A.

B-44 In paragraph 5-32 replace the second sentence with the following: "Therefore at the same 40 V output, the load would have to decrease 0.72 Ω from 4.00 Ω to 3.28 Ω to increase the output current by 2.2 A from 10 A to 12.2 A."

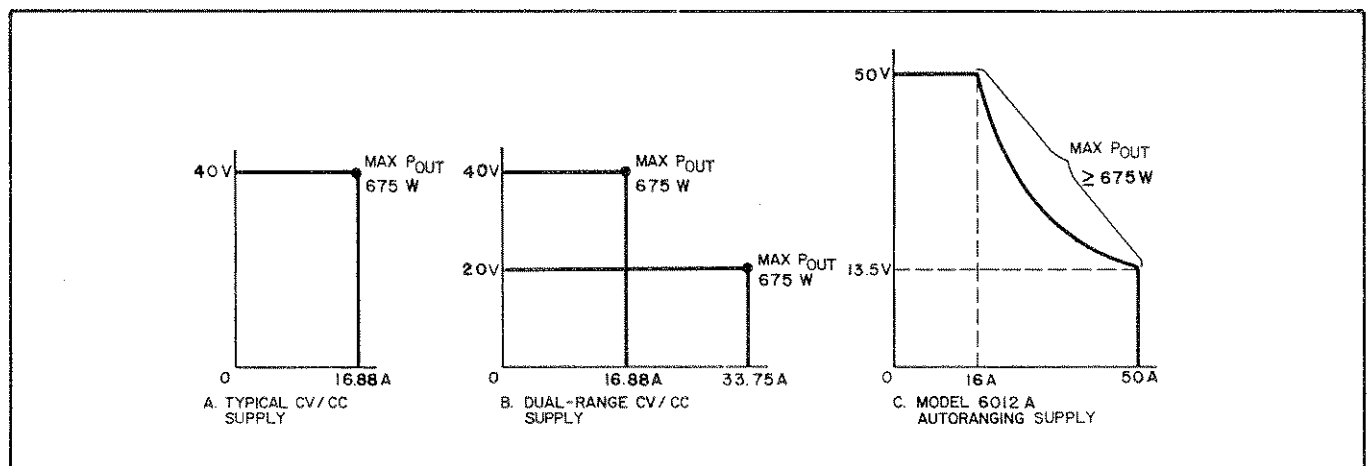

Figure B-2. Output Characteristics, Typical, Dual Range and Autoranging Supplies

- B-45 In paragraph 5-38, j; change 80 mV to 70 mV.
- B-46 In paragraph 5-41, h; change 23 mVdc to 20 mVdc.
- B-47 In Table 5-3 under CV Circuit, line 1; change "5 volts" to 4.2 volts".
- B-48 In Table 5-4, second line; change 25 V to 16 V.
- B-49 In paragraph 5-93, j; and 5-93, l; change 22 V to 14.5 V.
- B-50 In paragraph 5-93, k; and 5-93, l; change 240 V to 206 V.

B-51 REPLACEABLE PARTS

B-52 Section VI Manual Changes

B-53 For Option 100 change R136 to 24.9 k Ω \pm 1%, 1/8 W, HP Part Number 0757-0311. Change R151 to 182 k Ω \pm 1%, 1/8 W, HP Part Number 0698-4486. Change the Voltmeter and Ammeter to HP Part Numbers 1120-1396 and 1120-1397. Also add the front panel overlay, HP Part Number 06012-00013 and the 90-105 V line label, HP Part Number, 7120-2087.

B-54 APPENDIX A

B-55 Appendix A Manual Changes

B-56 Under Remote Programming for Constant Voltage Output, in Table A-1 and in paragraphs A-22, A-24, and A-30; Resistance Programming requires a 0 to 2083 Ω programming resistance, Voltage Programming requires a 0 to 4.17 V programming voltage and the Current Programming requires a 0 to 1.67 mA current sink, to program the output from 0-50 V. The Constant Current programming values for Option 100 are the same as those shown in the Appendix A.

B-57 In Table A-1, and paragraphs A-22, A-24, A-26, A-30, and A-33 change "maximum rated voltage or current output," or "full scale voltage" to "50 V" or "50 A".

B-58 SCHEMATIC

B-59 Schematic Changes

B-60 Change R136, located in the Overvoltage Protection circuit, to 24.9 k Ω , 1/8 W. Change R151, located in the Overvoltage Protection Circuit, to 182 k Ω , 1/8 W. Also, change the dc input to the FET switches from approximately 300 Vdc to 250 Vdc.